

# LINEEYE

*MULTI PROTOCOL ANALYZER*

***LE-8500XR-RT***  
***LE-8500X-RT***

---

---

INSTRUCTION MANUAL

---

---



# Instruction

---

---

Thank you for your purchase of LE series.

To use it correctly, you are advised to read and understand this instruction manual thoroughly. Keep this together with the warranty. If you encounter any problems, you will find helpful information in this manual.



## NOTICE

---

It is prohibited to reprint or duplicate any part of the whole of this instruction manual without prior permission from LINEEYE.

The content of this instruction manual and specifications of the products are subject to change without any notice.

This instruction manual has been designed and edited with great care to give you all necessary information. If you have any questions, feel free to direct your inquiries to LINEEYE.

LINEEYE makes no warranty or guarantee, either expressed or implied with respect to its quality, performance, merchantability, or fitness for a particular purpose. LINEEYE shall not be liable for direct, indirect, special, incidental, or consequential damages resulting from any defect in the product. The warranty and remedies set forth above are exclusive and in lieu of all others.



## USER LIMITATION

---

This product has not been developed for the use that needs exclusively high reliability and safety: aerospace apparatus, trunk communication apparatus, nuclear control apparatus, medical apparatus related with life maintenance etc. Therefore, do not use for those purposes.

LE-series models with Wi-Fi function (IEEE 802.11b/g/n) emit radio wave. Please do not use it near a medical device, microwave, high-level electronics, TV, radio, wireless station for mobile communication, or specified low power radio station. To use LE-series in the place where an administrator limits the use of radio devices, follow the instruction of the administrator.

The Wi-Fi module used for the LE-series conforms to SRRC(China), FCC (USA), CE (EU), TELEC (Japan), KCC (Korea), ISED (Canada), NCC (Republic of China), however, as its product (LE-series) the Wi-Fi function is available only in Japan, USA, Canada, and EU nations in compliance with RE directive (2014/53/EU).

To use the product other than above countries, order LE-series without Wi-Fi function. Please contact the sales department for more details.

=== Notice ===

This product contains a lithium-ion battery.

To keep the quality of the battery, LINEEYE does not fully charge the battery. Before using the battery, please make sure to charge the battery. When you dispose it, please recycle it in accordance with the local laws and regulations of each country.

# Safety Information



## Read this first !!

This Safety Information includes the following important information in order to not only have you learn the right way to use the analyzer, but also prevent you from causing damage to people and property. Before using,

please read the main contents after you understand the following symbols & marks.



**Warning**

Should the device be used without following these symbols, there is a possibility of accidents, such as a death or a serious injury, occurring.



**Caution**

Should the device be used without following these symbols, there is a possibility of accidents, such as an injury (\*1), and material damage (\*2) occurring.

\*1 : “Injury” indicates injury, burn and electric shock, or the like which does not require hospitalization or the extended hospital visit.









\*2 : “Material damage” indicates damage related to a house, a building, furniture, apparatus, livestock or a pet.







**Prohibition**





**The necessary**

 <b>Warning</b>	
	<ul style="list-style-type: none"> <li>Do not disassemble, modify or repair the line monitor This may result in an injury, electric shock, and ignition.</li> </ul>
	<ul style="list-style-type: none"> <li>Turn off the power of analyzer and unplug the cables immediately when emanating smoke, odor or sound. Continuous use may result in an electric shock, injure or ignition.</li> </ul>
	<ul style="list-style-type: none"> <li>Do not use the line monitor if there is inflammable gas. This may result in ignition and explosion.</li> </ul>
	<ul style="list-style-type: none"> <li>Turn off the power and unplug the line monitor immediately when liquid or foreign substance gets into the line monitor. Continuous use may result in ignition, electric shock and malfunction.</li> </ul>
	<ul style="list-style-type: none"> <li>Do not touch the line monitor with wet hand. This may result in an electric shock and malfunction.</li> </ul>
	<ul style="list-style-type: none"> <li>Do not use the battery other than attached Lithium ion battery. Do not short the electrode of the battery. Do not modify, decompose or heat the battery It may cause the ignition and explosion.</li> </ul>
	<ul style="list-style-type: none"> <li>Do not give a strong impact on the product, such as dropping and crashing.</li> </ul>

 Caution

 Caution	
	<ul style="list-style-type: none"><li>• Do not leave the analyzer in the following conditions.<ul style="list-style-type: none"><li>▪ Strong magnetic field, static electricity or dusty place.</li><li>▪ Temperature and humidity above the specification or where dew condensation appears.</li><li>▪ Not flat, or shaking place.</li><li>▪ Place with leaking water or electricity</li><li>▪ Place affected by direct sun or near the fire.</li></ul></li></ul> <p> Please do not leave the analyzer in the car during the summer.</p>
	<ul style="list-style-type: none"><li>• Do not use at the following situations. The radio wave by the analyzer may cause trouble.<ul style="list-style-type: none"><li>▪ Near a medical device such as cardiac pacemaker or hearing aid.</li><li>▪ Near an automatic controller such as fire-alarm box or automatic door.</li><li>▪ Near a microwave, high-level electronics, TV, or radio.</li><li>▪ Near a wireless station for mobile communications or a specified low power radio station.</li></ul></li></ul>
	<p>Remove the battery from the analyzer, when you throw away.</p>

 Caution

 Caution	
	<ul style="list-style-type: none"><li>• Please follow the instruction for the USB Battery Charger. It may cause the generation of heat, injure, electric shock and malfunction<ul style="list-style-type: none"><li>▪ Do NOT use it for other than AC 100V to 240V</li><li>▪ Do no use when it brakes.</li><li>▪ Do not twist or step on the cable of charger. (Do not stress the base of cable.)</li><li>▪ Do not place near the heater or put in the fire.</li><li>▪ Do not disassemble, modify the USB Battery Charger or cable.</li><li>▪ Do not curve the cable around the USB Battery Charger.</li><li>▪ Do not put many loads on one electrical outlet.</li></ul></li></ul>
	<ul style="list-style-type: none"><li>▪ Insert it well to the electrical outlet.</li><li>▪ Remove the dust on the AC plug.</li><li>▪ Unplug the charger if you do not use it.</li><li>▪ When unplugging from the outlet, pull out the body straight.</li></ul>

# CONTENTS

---

---

<u>Safety Information</u>	<u>2</u>	<u>Chapter 4 Simulation Function</u>	<u>75</u>
<u>Chapter 1 Before Using the Product</u>	<u>6</u>	4.1 Register Transmission Data .....	76
1.1 Description on This Manual .....	6	4.2 RS-422/485 Driver Control .....	84
1.2 Unpacking .....	6	4.3 Auto Line Control .....	85
1.3 Functions and Feature.....	7	4.4 Manual mode.....	87
1.4 Name of Each Part.....	8	4.5 Buffer Mode .....	89
1.5 Power Supply and Battery.....	12	4.6 Flow Mode.....	91
1.6 Hand Strap.....	14	4.7 Echo back test (ECHO mode).....	95
<u>Chapter 2 Basic Operation and Set-up</u>	<u>15</u>	4.8 Polling mode .....	97
2.1 Power Source ON (Opening Screen)	15	4.9 Program mode.....	102
2.2 Top Menu.....	16	4.10 Commands for Program Mode.....	107
2.2.1 Switching between normal mode and high-speed mode ..	17	4.11 Pulse Generator Mode (PULSGEN).....	129
2.2.2 File Manager .....	17	<u>Chapter 5 BERT Function</u>	<u>132</u>
2.2.3 Record Control.....	17	5.1 Connection and Settings .....	132
2.2.4 System Config.....	23	5.2 Start and Stop.....	136
2.2.5 Diagnostics function.....	27	5.3 Contents of the Line Quality Data...	137
2.2.6 Time Settings .....	28	<u>Chapter 6 Useful Functions</u>	<u>138</u>
2.3 Measurement Port.....	29	6.1 Trigger Function.....	138
2.4 Communication Condition Settings .	31	6.2 Timer/Counter Function .....	146
2.5 Connection.....	44	6.3 Timing Waveform Measurement Function...	147
2.6 Connection and Setting of Time stamp Synchronous Function	50	6.4 Auto Configuration Function.....	151
<u>Chapter 3 Monitor Function</u>	<u>51</u>	6.5 Split Display .....	152
3.1 Online Monitoring (ONLINE).....	51	6.6 Translation Function .....	153
3.2 Retrieval Function.....	69	6.7 Auto Save Function.....	157
3.3 Delay Time and Signal Voltage (DELAY)....	71		
3.4 Statistic Analysis Function (Trend) ..	73		

Chapter 7 Save and Load of the Data 158

7.1 Storage device..... 158

7.2 File Management Function ..... 159

Chapter 8 Utility 167

8.1 PC Link Function ..... 167

8.2 Capture data files while measuring . 169

8.3 PC Remote Control Library..... 170

Chapter 9 Printout Function 171

9.1 How to Connect to a Printer..... 171

9.2 Hard Copy of Screen Display ..... 171

9.3 Printout of Measurement Data .. 172

Chapter 10 Documents 173

10.1 Calculation of the Block Check..... 173

10.2 Send/Receive Clock ..... 175

10.3 About the Frame ..... 177

10.4 Data Code Chart..... 178

10.5 Translation Display Specification .. 182

Chapter 11 Specifications and  
Maintenance 196

11.1 Specifications of Function and  
Hardware... 196

11.2 Signal Definition of the  
Measurement Ports ..... 197

11.3 Shortcut Keys ..... 202

11.4 Expansion of measurement  
interface..... 202

11.5 Factory reset ..... 203

11.6 How to update the firmware..... 203

11.7 Trouble shooting ..... 204

11.8 Warranty and After service..... 206

# Chapter 1 Before Using the Product

## 1.1 Description on This Manual

---



### Function for different model



---

- When the performance or function differs depending on the model of the protocol analyzer, [Model number] is described side by side.



### Deception of the Operating Procedure

---

- Printed representation of screen displays in the manual may not be the same as that actually displayed concerning the font and special symbols.
- Descriptions of items of the screen are enclosed in double quotation marks “ ”.
- Reference page is described with  .
- Represent key is enclosed in [ ].  
e.g. Press “  ” key. : Press [MENU].
- Successive key or tap operations may be represented by putting their symbols one after another.  
e.g. Press [MENU], then press [0]. : Press [MENU] -> [0].  
e.g. Tap [A], then tap [B]. : Tap [A] -> [B].
- Pressing two keys at the same time is represented by combining their symbols with “+” .  
e.g. Press [SHIFT] and [ESC] at the same time : Press [SHIFT]+[ESC].

## 1.2 Unpacking

---

When you unpack the product, check the items below:

- The product has not been damaged during the transit.
- You have received all the standard accessories listed below.
  - Protocol Analyzer 1
  - Interface Sub-board [SB-R2TS1 ] (attached to the analyzer) 1
  - DSUB 25pin monitor cable [LE-25M1] 1
  - DSUB 9pin monitor cable [LE-009M2] 1
  - DSUB25pin-9pin conversion adapter 1
  - 5 wires TTL probe cable [LE-5LS] 1
  - Hand strap (Already mounted) 1
  - Wide input AC adapter (Input :AC100-240V / Output :DC9V) 1
  - USB cable (Type A-C) 1
  - Utility CD 1
  - Quick Start Guide 1
  - Carrying bag [LEB-01] 1
  - Warranty 1

 The card packed with the product is the user registration card for Japanese customers. For overseas customers, there is a user registration page on our web site.( <https://www.lineeye.com> )

Please let us know if you find any damage to the product or accessories lacking.

## ○ Utility CD

Utility CD contains following files

Manual folder : Instruction manual for the analyzer

Utility folder : Various Utilities

## 1.3 Functions and Feature

---

LE-8500X-RT/LE-8500XR-RT is a multi-protocol analyzer that can measure and test RS-232C, RS-530, RS-422/RS-485, and TTL level serial communication by one unit. Using the monitor function, communication simulation function, bit error rate function, etc. according to the test situation, it can be widely used for the development/maintenance of PC peripherals, serial interfaces of FA equipment, and UART, SPI, and I2C of embedded boards.

### ◆ Online monitor function

This function is used to monitor communication protocols and transmission/reception data in an online state, and to analyze the presence or absence of failures and their details.

### ◆ Simulation function

This function can perform data transmission/reception operations as a communication partner of the device to be tested.

### ◆ Bit error test function

This function evaluates the quality of data communication lines including modems.



## Features

---

- Supports RS-232C, RS-530, RS-422 / RS-485, and TTL just by one unit.
- Supports legacy interfaces such as V.35, X.20 / 21, RS-449.
- Program simulation function that enables flexible communication tests
- Bit error rate test function for transmission quality analysis
- Reproduces and outputs a timing waveform data acquired by the logic analyzer function
- Time stamp that allows time synchronization by GNSS (PPS) signal
- Automatically records communication logs to large-capacity external storage via USB3.0
- Newly designed lightweight housing with 7-inch color LCD with touch panel
- Saves measurement reports in snapshot
- PC link by LAN, USB, or Wi-Fi (XR only) connection



## Optional Accessories

---

- Expansion kit for GbitLAN communication SB-GE2
- Expansion kit for LAN/PoE (2ch) measurement (EtherCAT supported) SB-FE2
- Expansion kit for Single Pair Ethernet SB-T1E
- Expansion kit of CAN/High-speed Analog SB-C2AN
- GPS active antenna EB-SL-AA170
- PPS signal I/O cable LE-PPS-2
- Coaxial cable for PPS synchronization LE-SMA-LS-2
- X.21 monitor cable LE-25Y15
- RS-449 monitor cable LE-25Y37
- V.35 monitor cable LE-25M34
- RS-530 cable LE-25S530
- PC link software LE-PC800X
- 8GB SDHC card SD-8GX
- 16GB SDHC card SD-16GX
- 32GB SDHC card SD-32GX
- Portable thermal printer SM4-31W
- Lithium ion battery pack P-26LW2

## 1.4 Name of Each Part

### General

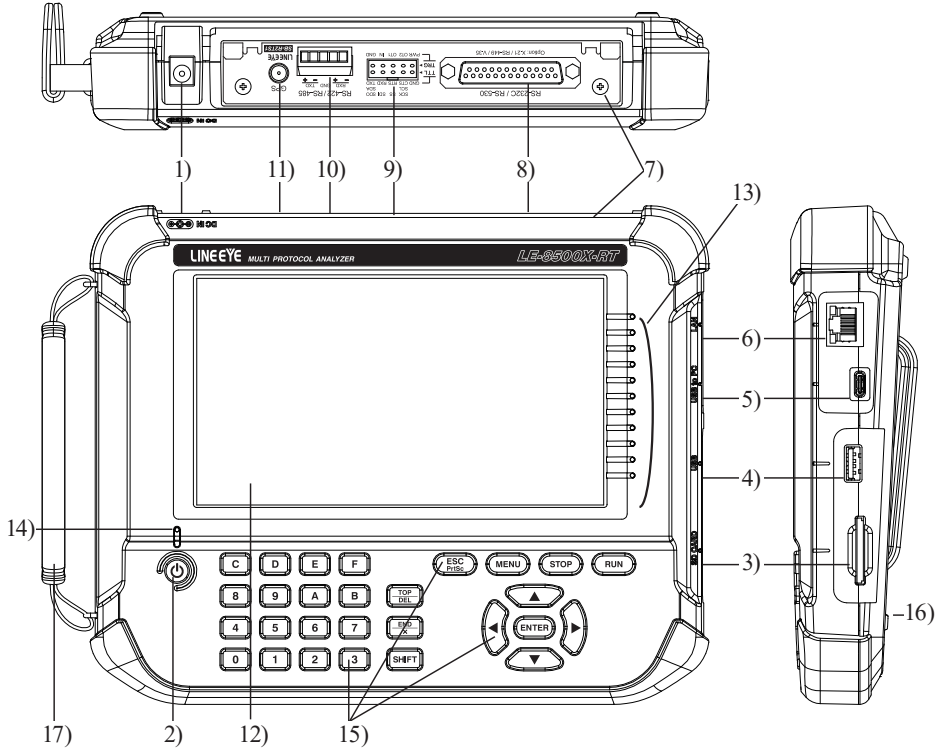

Name	Description
1) AC adapter plug	Connects the AC adapter, which serves as a battery charger.
2) Power Switch	Press for about 1 second to turn the power on/off.
3) SD Card Slot	The inlet for a SD/SDHC card.
4) USB Host Port	Connection port for a USB flash drive or Printer.
5) USB Device Port	USB Type-C connector connected to a PC or battery charger
6) LAN port	RJ-45 connector. Link: LED (right), 1000BASE-T connection: LED (left) Used when connecting to a PC via wired LAN.
7) Inter face Sub -Board	The SB-R2TS1 sub-board is installed. It can be exchanged with other optional measurement sub-boards.
8) RS-232C,RS-530 Port	RS-232C (V.24) and RS-422/485 (RS-530) measurement ports <sup>(*)</sup> Dsub25 pin (female)
9) TTL,trigger I/O port	TTL measurement port and external signal I/O port. Pin header, 10 poles.

10)	RS-422/485 Port	RS-422/485 measurement port <sup>(*)1</sup> . Detachable terminal block, 5 poles.
11)	GPS antenna connector	SMA (female) connector When synchronizing the time with GPS, connect the optional GPS antenna .
12)	7 Inch Color Display	7 Inch Color Display with capacitive touch panel.
13)	Line State LED	Displays the status of the interface to be measured.
14)	Power LED	Lights in green when the power is turned on. Blinking in red when charging battery.
15)	Keypad	Entering commands and other operation.
16)	Battery Cover	Open/close when replacing the battery.  1.5 Power Supply and Battery
17)	Hand Strap	Use to hold the product.

\*1 : The RS-422/485 signal lines of the RS-422/485 port and the RS-232C/RS-530 port are connected inside the unit, so do not connect them at the same time.



## LED and Display

### ■ Power LED

Light in green during operation. Blink in red while it charges a battery.

Slow charge (when AC adapter is connected) : Blink per 1 sec.

Normal charge (when connected by USB Type-C) : Blink per 1.5 sec.

Fast charge (when connected via other USB) : Blink per 4 sec.

 1.5 Power Supply and Battery

### ■ Line state LED

Tap “LED” at the bottom right of the screen to display the meaning of each LED.

If you tap anywhere in the area while it is displayed, it will be hidden.

You can also switch shown/hidden the display of the meaning of each LED by pressing [SHIFT] + [MENU].

 The meaning of the display state changes depending on the interface board.

## ■ Data display window

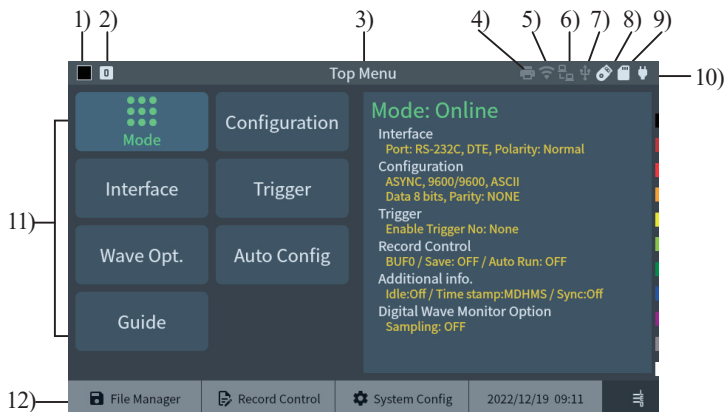

1)	Measuring “●”, Pause “■”
2)	Current status of the capture buffer. Entirely in use  / : Divided into 2 parts and in use.  2.2.3 Record Control
3)	Description of the current window.
4)	USB printer status (bright display when connecting)
5)	Wi-Fi status (bright display when IP address is acquired or access point is ready) Not displayed on models that do not support Wi-Fi.
6)	Wired LAN status (bright display when IP address is obtained)
7)	Status of USB device port. (Connected when the color is bright, “” is displayed when it is in super speed.)
8)	Status of USB host port. (Bright color when recognizing, red when writing)
9)	Status of SD card slot. (Bright color when recognizing, red when writing)
10)	Estimated battery level is displayed, and “” is displayed when power is supplied from the outside.
11)	Setting items or measured data.
12)	Touch panel for advanced settings.

## Key operation

There is a keyboard to input data and operate commands.

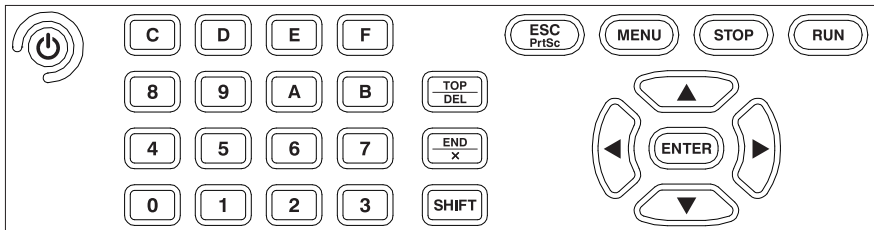

### ■ Keys

Operations	Function
[  ]	Turn ON/OFF the power. Press it for more than 1sec.
[RUN]	Start monitoring, measuring or testing operation.
[STOP]	Stop monitoring, measuring or testing operation.
[MENU]	Return to the top menu.
[ESC]	Return to the previous display Return to the data display from configuration.
[ ▲ ], [ ▼ ]	Scroll one data line. Move the cursor on the condition setting.
[ ◀ ], [ ▶ ]	Scroll one character of data. Change the setting on the condition setting.
[ENTER]	Apply selected settings.
[0]~[F]	Enter numerical values.
[TOP/DEL]	Delete the entry indicated by the cursor.
[END/X]	Enter the data of "Don't Care".
[SHIFT]	Press to use the expanded alternate function of each key.
[SHIFT]+[TOP/DEL]	Jump to the top of data.
[SHIFT]+[END/X]	Jump to the end of the screen.
[SHIFT]+[ESC]	Save the screen image. / Hardware copy.
[SHIFT]+[MENU]	Display/hide the description of LEDs.
[SHIFT]+[RUN]	Brighter the LCD back light.
[SHIFT]+[STOP]	Darker the LCD back light.
On the top menu [SHIFT]+[0]	Switch to the normal mode.
On the top menu [SHIFT]+[3]	Switch to the high-speed mode.

\* [X]+[Y] indicates the operation of pressing [X] and [Y] together at the same time.

 Shortcut keys are available from [MENU] and [0]~[F].

 11.3 Shortcut Keys

### ■ Touch panel

Following operation is available.

Tap	Tap the screen once to select the setting etc.
Double tap	Tap the screen twice to select and execute the setting.
Swipe	Touch and slide the finger to scroll data.

## 1.5 Power Supply and Battery

### ■ Power supply

Works with the included AC adapter or built-in lithium-ion battery.

- ☞ Battery life is about 4 hours. Increases or decreases depending on usage.
- ☞ It does not work with bus power supply from the USB device port.

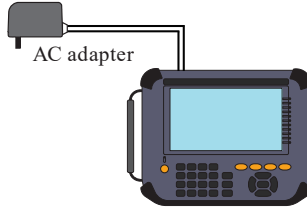

### ■ Charge the Battery

The built-in lithium-ion battery is charged when powered by the AC adapter or bus-powered from the USB device port.



The charging time will be as follows depending on the usage conditions.

Power supply	Analyzer	Status	Charge Time	Power LED blinking
AC adapter	OFF	—	About 3.5 hours	Approx. 1sec cycle
	ON	Stop measuring	Max. 6 hours <sup>*1</sup>	Approx. 4sec cycle
		Measuring	No charge	No blinking
USB bus power	OFF	Use attached USB cable	Max. 6 hours <sup>*1</sup>	Approx. 4 sec cycle
		Use Type-C battery charger etc. <sup>*2</sup>	About 4.5 hours	Approx. 1.5 sec cycle
	ON	—	No charge	No blinking

\*1 : This will not be full charging because of the small amount of current (approx. 160mA).

\*2 : It will be the same when it connects to the PC with a USB port in Type-C connector.

- ☞ This analyzer is not charged in full before shipping. To use the analyzer at the first time, charge it full.
- ☞ Charge the analyzer under the temperature of 5 to 40 °C. It will not start charging below 5 °C.
- ☞ If you are not going to use it for a long term, charge the battery in full. After that, try to charge the battery every 6 months.

■ Replace the Lithium ion battery

If the analyzer can no longer drive by the battery, or the service time after charging becomes extremely short, replace the battery.

Disconnect the cables, turn off the analyzer, remove the battery cover, and replace the old battery.

📄 As batteries are consumables, the replacement of a battery will cost you even during the warranty period.

📄 Old battery has to be handled in an appropriate manner.

📖 11.8 Warranty and After service

To replace the battery, purchase LINEEYE Lithium ion battery pack (model: P-26LW2), and do not use any other.

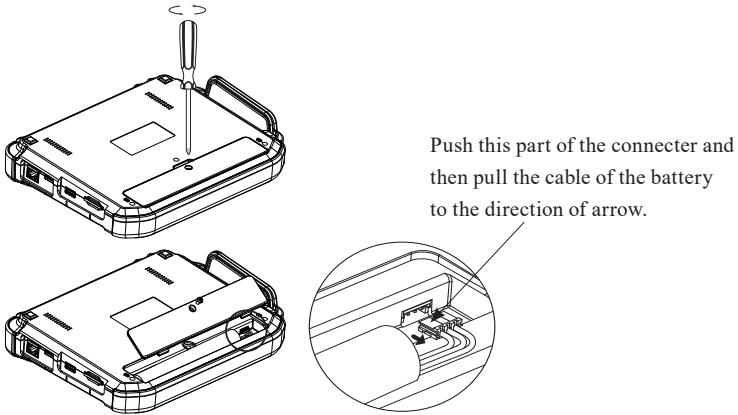

📄 The battery is necessary for protection in the event of a sudden power failure, so be sure to install and use it.

■ Lithium primary battery

The clock built into the unit is backed up by the built-in lithium primary battery for about 5 years even when the power is turned off.

📄 If the watch goes wrong or will be reset, replacement of the lithium primary battery at our factory is required. In that case please contact LINEEYE or LINEEYE distributor.

## 1.6 Hand Strap

You are able to put and remove this hand strap.



### Put on the hand strap

Hand strap is already set in the analyzer when you purchase.

<Remove the hand strap>

- 1) Open the Velcro.
- 2) Remove the belt.
- 3) Remove the hand strap from the analyzer

 Reverse the process when putting on the hand strap.

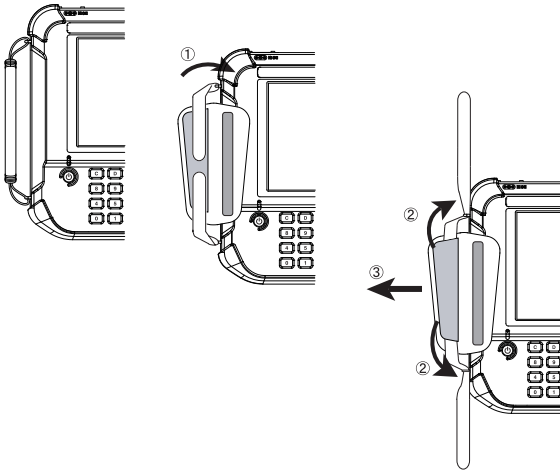

### NOTICE

Put each magic tapes of the belt in the hand strap for 3cm or more.

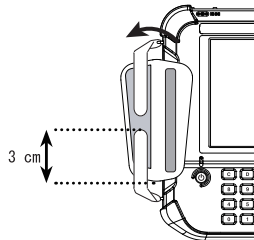

# Chapter 2 Basic Operation and Set-up

## 2.1 Power Source ON (Opening Screen)



### Power Source ON

Press [  ] for about 1 second to start and display the opening screen. It takes about 15 seconds to start. At the first boot, the Japanese-English display language selection screen will be displayed. When it is already set, the top menu screen will be displayed.



Both LE-8500XR-RT and LE-8500X -RT models are displayed as “LE-8500X”.



### Language (English or Japanese)

At the first boot, you can switch the display language between Japanese and English. To change the already set one, set it at “Language” in the system settings from the top menu screen.



#### 2.2.4 Record Control ■ Language

This setting is valid until the system is initialized or the system is recovered from the firmware update operation.

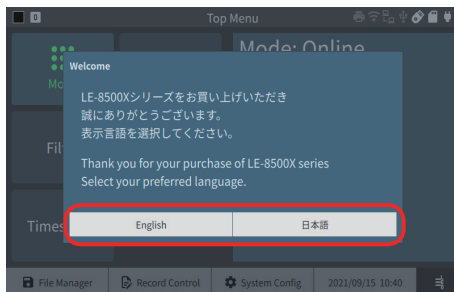

#### 11.5 Factory reset



#### 11.6 How to update the firmware



### Power Source OFF

Press and hold the power switch for about 1 seconds to turn off the power of analyzer. The setting data and captured data are saved in the inner memory of analyzer for about 16M byte. To save all data, use the SDHC card or USB flash drive.

If you want to erase all the contents of the capture memory when the power is turned off, turn off the auto backup function.



#### 2.2.3 Record Control

## 2.2 Top Menu

Press [MENU] to set the initial settings.

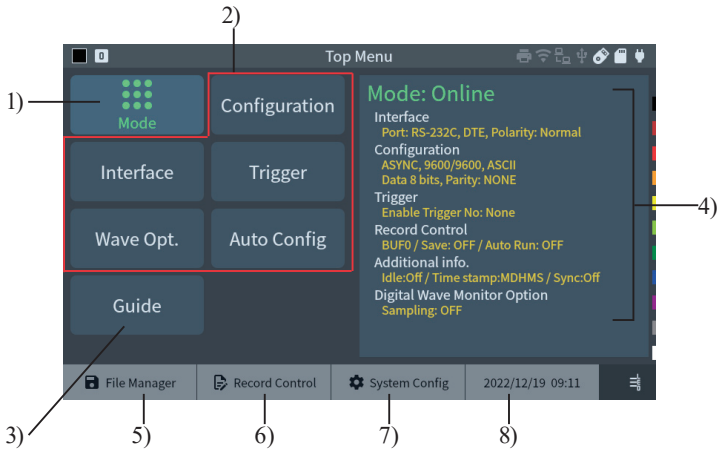





Touch the setting item, or press [ENTER] after selecting the item by [ ▲ ] [ ▼ ] [ ◀ ] [ ▶ ]

Press [ESC] to move to the measurement result display screen.

To switch the measurement mode, tap “Mode” or press [ENTER] while selecting “Mode” and select from the displayed mode list.

You can call up each setting screen by touching “File manager”, “Record Control”, “System Config”, and the current time display at the bottom of the top menu screen.

1)	Switch the measurement mode.
2)	Depending on the selected measurement mode, the necessary setting items are displayed.
3)	Display the operation guide.
4)	Displays the currently set measurement mode setting. You can also tap this part to move to the setting change screen.
5)	Save/read to a file.  2.2.2 File Manager
6)	Configure settings related to the capture buffer for recording measurement data and the save destination.  2.2.3 Record Control
7)	Configure settings related to screen brightness, network, language, firmware update, etc  2.2.4 System Config
8)	Set the time.  2.2.6 Time Settings

## 2.2.1 Switching between normal mode and high-speed mode

The LE-8500X-RT can be used by switching between a mode for normal measurements and a high-speed mode that supports measurements of up to 20Mbps (30Mbps for SPI only).

Press [SHIFT]+[0] on the top menu screen to enter normal mode, and press [SHIFT]+[3] to enter high-speed mode.

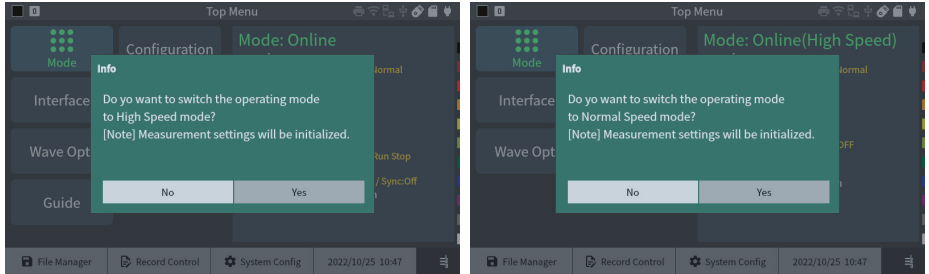

## 2.2.2 File Manager

Save/read to a file.

 Chapter 7 Save and Load of the Data

## 2.2.3 Record Control

Configure settings related to the display of time stamps, etc., the capture buffer that records measurement data, the saving method, and automatic measurement.

### ■ Additional info.

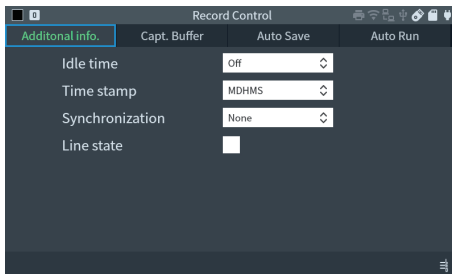

### ◆ Idle time

It displays the non-communication time when there is no change in transmission/reception data and control line. “Do not record” or set the time resolution to 100 ms, 10 ms, or 1 ms.

 This is not available in high-speed mode.

 2.2.1 Switching between normal mode and high-speed mode

When you switch between high-speed mode and normal mode, settings other than the transmission data table of the simulation function and the simulation program are initialized. If you want to reuse the settings, save the setting data for each mode to a storage device before switching.

◆ Time stamp

The time when the first data of the communication frame was captured can be recorded in the capture buffer as a time stamp.

Set “Off” or the time resolution from “Day Hour:Minute”, “Hour:Minute:Second”, “Minute:Second.10msec”, “Year/Month/Day Hour:Minute”, “Month/Day Hour:Minute:Second”, “Day Hour:Minute:Second.10msec”, “100μs”, “10μs” or “1μs”.

In the high-speed mode, the time resolution is “1 ms”, “100 μs”, “10 μs”, and “1 μs”.

◆ Synchronization

Set to synchronize timestamps to a 1 second reference (PPS) signal.



2.6 Connection and Setting of Time stamp Synchronous Function

None	Uses the built-in RTC of analyzer
GPS time	Synchronize with PPS signal obtained from GPS
Ext. PPS(TRG IN)	Synchronizes with the PPS signal input from the PPS terminal

☰ When either synchronization is enabled, it takes 3 to 4 seconds to actually start the measurement because the synchronization work starts at the start of the measurement.

If a valid PPS signal cannot be received during that time, an error will occur and the measurement will not start. Be especially careful when using the automatic measurement function.

☰ For external PPS synchronization, the measurement start time is the positive second (○○seconds .000000000) closest to the current internal clock time. If you want to synchronize the data time stamp with UTC as well as the relative time after the start of measurement, you need to set the built-in clock to an error of less than 0.5 seconds in advance using NTP etc.

☰ If “OT2 pulse output” is set as the operation of any trigger function, the function to send the PPS signal from TRG OT2 of this unit to the second analyzer will not work even if it is set to “GPS time”.

☰ When using an external PPS, if the polarity inversion check box is not checked, the time is adjusted by detecting the falling edge of the TRG IN terminal. Do not check if the device that outputs the PPS signal is another LE-8500X series or the device that outputs PPS at the falling edge of the time. Check this when using a PPS signal output device that outputs the time at the rising edge.

◆ Line state

Mark on the box to record the line states (RTS, CTS, DCD, DTR, DSR, RI, TRG) along with the measured data. If it sets the idle time, idle time of the line states will be recorded as well.

## ■ Capture Buffer

Tap the tab of “Capt. Buffer” and set the capture memory setting of recorded data.

### ◆ Recording area

The capture memory is 1024 Mbytes.

Select whether a memory is used as one capture buffer or two capture buffers.

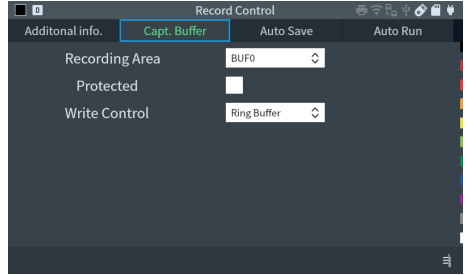

BUF 0 : The whole buffer can be used as one capture buffer.

BUF 1/2 : The capture buffer is divided into two (BUF1 and BUF2) and they are used to measure separate data.

Select when comparing measurement data.

### ◆ Protected

Mark on the box to prevent data recorded in the buffer memory from being inadvertently overwritten.

 Do not mark on the box when it uses Auto-save function.

### ◆ Write Control

Select the recording type of capture memory.

Ring Buffer :

When the capture memory is used up, the data is overwritten from the beginning of the memory and the communication data is recorded endlessly.

Full Stop :

When the data is recorded to the end of the capture memory, the measurement is automatically stopped.

 When using the Auto save function, set to “Ring Buffer”.

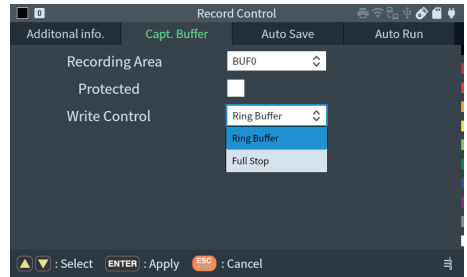

## ■ Auto save function

Tap the Auto Save tab to configure autosave settings and auto backup settings.

By using the auto save setting, you can automatically save the contents of the capture buffer (that is taken by monitoring in real-time) continuously for a long period of time as a measurement log file (auto save file) of a specified size to a storage device such as an SD card. As you can use the file management function to check the auto-save file that was automatically saved during the period when a communication failure occurred, it is useful to analyze a rare failure.

 This is not available in Delay, Trend, and BERT modes.

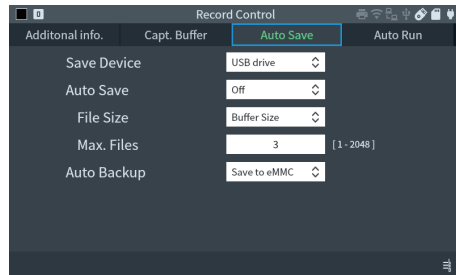

### ● Preparation and settings

Insert an SD card or USB memory of the appropriate capacity into this unit according to the time you want to record continuously.

If the speed of writing to a storage device is relatively slow to the amount of data to be stored, the writing will not be in time and log data will be lost.

#### ◆ Save Device

Select the storage device to save the auto save file. Specify the SD card or USB flash drive inserted in the analyzer.

#### ◆ Auto Save

Set the condition of the auto save function.

Off : Auto save function does not work

Restart : Continuous ring recording of auto-save files within the maximum number of files

Max-stop : Saves up to the specified number of auto save files and stops measurement

Append : Continuous ring recording from the file number next to the existing auto save file number

 The name of the auto-save file which is automatically saved is #XXXXXXX.DT (XXXXXXX is a sequential number that increases by 1 from 0000000)



- If you set “Restart” or “Max-Stop”, all existing auto save files will be deleted at the start of measurement
- When saving the measurement log for a long time with the auto save function, set the main unit capture memory to the ring buffer. Also, make sure that the trigger condition that stops the measurement is not set.

◆ File Size

Specify the file size of the auto save file from 4M, 16M, 64M, 256Mbytes or “Buffer size” . The “Buffer size” will be the same as the capture memory size. Max files



◆ Max. Files

Set the maximum number of auto save files to be automatically saved.

- Even if the storage device has free space, it may not be able to store the specified maximum number of files due to media limitations.

■ Auto backup function

As the data in the capture buffer disappears when the power is turned off, the latest 16MB of measured data is automatically backed up in the built-in eMMC when the measurement is finished. If you want to automatically save the entire measurement data or delete the data when the power is turned off, change the setting of the auto backup function.

◆ Auto Backup

Specify the destination to save the automatic backup data.

The initial value is “Save to eMMC”

Off :

It does not execute automatic backup. Select this when you do not want to keep the measurement data after turning off the power.

Save to eMMC :

Saves the latest 16M bytes of measurement data to the built-in eMMC.

Save to File :

The entire buffer when a measurement is stopped is saved in the storage device specified in “Save Device”.

- When “Save to eMMC” is set, the measurement data saved in eMMC is automatically loaded to the capture memory when the power is turned on.

- When “Save to File” is set, all measurement data will be saved to a file named @AUTOBU<sub>n</sub>.DAT (n is the number of the used capture memory BUF0, BUF1 and BUF2). Load it manually to use it.

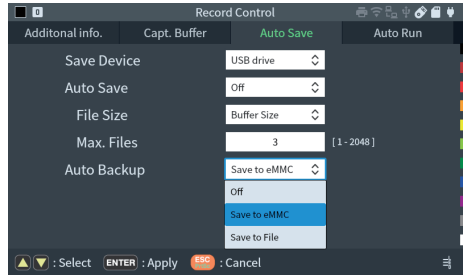

 7.2 File Management Function

## ■ Auto Run Function

By using this function, you can repeat the measurement automatically for the specified period by specifying the date and time when the measurement starts and ends. It can start the measurement in conjunction with power-on and automatically finish the measurement at the specified date and time.

### ◆ Auto Run mode

Select the measurement repetition period from Monthly (run monthly), Daily (run daily), or Hourly (run hourly).

### ◆ Run time

Set the date and time when to start the measurement according to the mode. It becomes effective when checked.

### ◆ Stop time

Set the date and time when to finish the measurement according to the mode. It becomes effective when checked.

### ◆ Standby power off

Set whether to enable the function to turn off the power while waiting for the measurement to start. If checked, the power will be turned off automatically after 10 seconds passes if there will be more than 5 minutes between the time when it is turned into the automatic measurement standby state and the start of the next measurement. After that, 3 minutes before the start of measurement, the power is automatically turned on and it is turned into the measurement standby state.

### ◆ Checking the power supply status

Set whether to enable the function to check the power supply from the outside at the start of measurement. When checked, if there is no external power supply when the measurement start time comes the measurement will not start and will remain in the standby state. If “Power off standby” is enabled at the time of this standby state, the power will be turned off automatically after 10 seconds passes.

### ◆ External power on Run

When checked, measurement will start 10 seconds after the power is supplied by the AC adapter. It is used when you want to start measurement in conjunction with the turning on by the external power.

## ● Control

When “Run Time” is checked, after pressing [RUN] it turns to be wait status until the specified time arrives. To cancel the waiting status press [STOP] or tap “Cancel”.

When the specified time comes, the measurement starts automatically. When the “Stop Time” is checked, the measurement is performed up to the specified time and the measurement automatically stops. This measurement process will be executed repeatedly according to the condition set at “Mode”.

When “External power on Run” is checked, when the power supply by the AC adapter is started while the power of this unit is off, the power will be automatically turned on, and 10 seconds after the boot is completed, the measurement starts automatically without pressing [RUN].

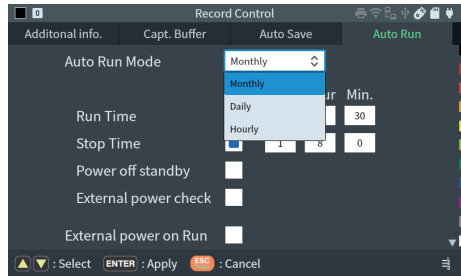
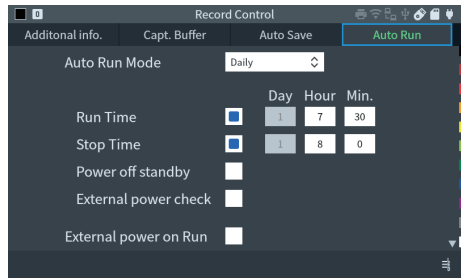

## 2.2.4 System Config

### ■ Display / Power

#### ◆ Backlight brightness

Adjust the brightness of the backlight.

The brighter the backlight, the shorter the running time (higher consumption of current).

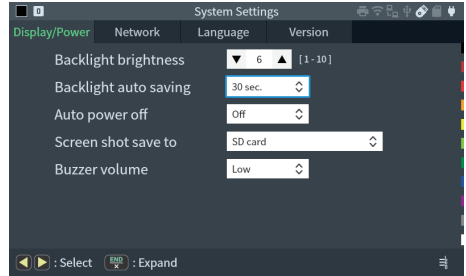

☰ You can also adjust the brightness of the backlight with [SHIFT] + [RUN] (bright) or [SHIFT] + [STOP] (dark). Use this operation when you want to change the brightness during measurement.

#### ◆ Backlight auto saving

Set the automatic backlight dimming time. If no operation is performed within the set time (15 seconds to 30 minutes), the backlight will be automatically darker to save power consumption. Set “Off” to invalidate this setting.

#### ◆ Auto Power Off

If no operation is performed for the set time (5 minutes to 60 minutes), the power will be automatically turned off to reduce unnecessary power consumption. Initial setting is “Off”

☰ While measuring data, auto-power off function will not work.

#### ◆ Screen shot save to

The screenshot of the display is saved to the connected external storage device. When both types of storage devices are connected, it is saved to the one specified in this setting.

When you select “USB printer” or “WLAN printer”, it will be hard-copied from the printer.

☰ Chapter 9 Printout Function

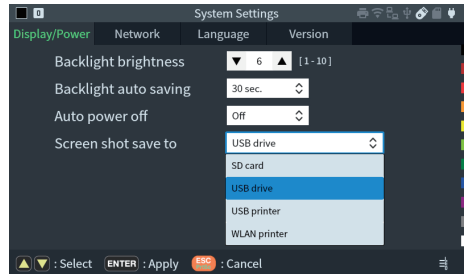

#### ◆ Buzzer Volume

Select the volume of the buzzer sound when triggered by the trigger function from “Low” or “High”.

☰ 6.1 Trigger Function

☰ Buzzer volume setting is available in system version V1.16 and later.

## ■ Network

At the time of shipment, the built-in Wi-Fi module is disabled and no wireless radio waves are output. When connecting to a computer remotely via wireless LAN, you need to set up a Wi-Fi connection.

 The Wi-Fi function is not available for LE-8500X-RT.

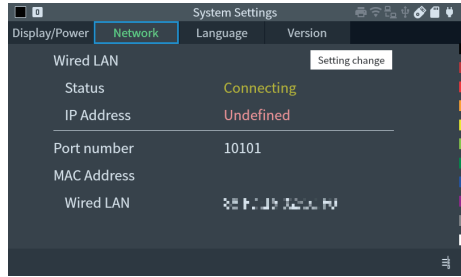

### ◆ Wired LAN

Status            Displays the status of the wired LAN connection.

IP address        Displays the IP address of this unit connected to a wired Ethernet LAN.

Tap “Setting change” to display the setting change screen.

#### • Port number

Set the port number of the analyzer. The port number is common to Wi-Fi connections. The initial value is “10101”.

#### • DHCP

Mark on the box when using the network which provides the IP address automatically. Remove the mark if using the specific IP address.

#### • IP Address

IP Address of the analyzer.

#### • Subnet mask

Subnet mask of the analyzer.

#### • Default gateway

Set the default gateway of this device.

#### • DNS server

Set the address of the DNS server.

### ◆ Wi-Fi connection

Status            Displays the status of the Wi-Fi connection.

IP Address        Displays the IP address of this device connected to Wi-Fi.

Tap “Setting change” to display the setting change screen.

#### • Port number

Set the port number of analyzer. The initial value is “10101”.

#### • Mode

Set the Wi-Fi connection method.

Off                The inner Wi-Fi module is invalid.

Station            The analyzer connects to the network via wireless access point.

Access Point      The analyzer itself becomes the wireless access point, and connects to the PC one by one.

## ○ Station Mode

- Port number  
Set the port number of analyzer. The initial value is “10101” .
- SSID  
SSID of wireless access point.
- Password  
Security key (encryption key) of wireless access point.  
 Input characters are changed to “●” for security purpose.
- DHCP  
Mark on the box when using the network which provides the IP address automatically. Remove the mark if using the specific IP address.
- IP Address  
IP address of the analyzer.
- Subnet mask  
Subnet mask of the analyzer.
- Default gateway  
Set the default gateway of this device.
- DNS server  
Set the address of the DNS server.

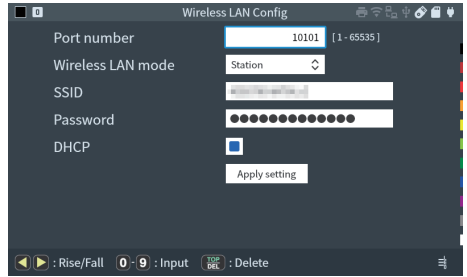

Before changing the IP address and DHCP, try to confirm with the person who is in charge of the network.

Tap “Apply setting” at the end. If the analyzer can connect to the wireless access point successfully, following display will be appeared.

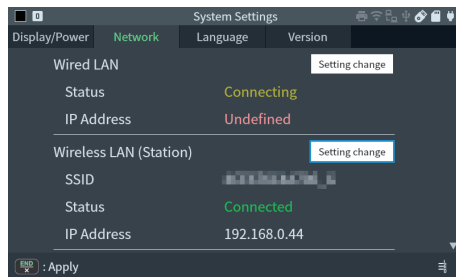

-  If the connection fails, try near a Wi-Fi access point.  
Also, double-check the SSID and password of the Wi-Fi access point.

## ○ Access point mode

Tap “Apply setting” at the end.

- Port number  
Set the port number of analyzer. The initial value is “10101” .
- Security  
Select the security protocol from OPEN, WPA, WPA2 or WPA/WPA2.  
 If selecting “OPEN”, the password will be invalid.
- SSID  
The initial value is “LE\_XXXXXXXX” . (XXXXXXXX is the serial number)  
If using more than one analyzers, each one should have different SSID.
- Password  
Security key (encryption key) of wireless access point.  
The initial value is “@XXXXXXXX#” . (XXXXXXXX is the serial number)
- Channel  
Select the wireless channel (1~11). If selected channel is crowded, try to use another channel.

When the wireless access point is set, the status display will be “Active”.

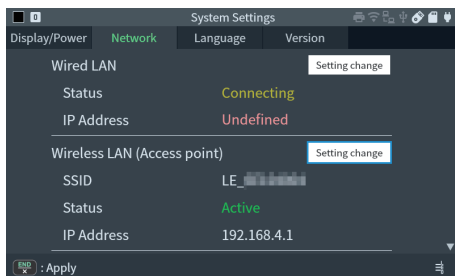
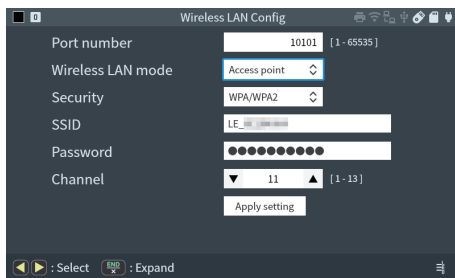

For access point mode, the IP address of analyzer is “192.168.4.1” and this cannot be changed. This , change the IP address of the target device (PC etc.) to the one within the same network group (exp. 192.0.168.4.2), or change the setting of the DHCP server to receive the IP address from analyzer.

## ■ Language

Select a language (English or Japanese).

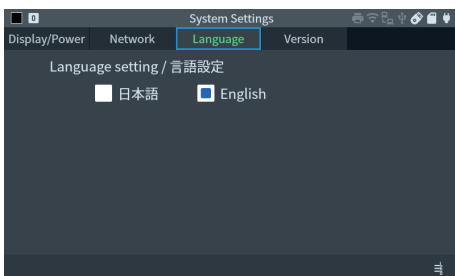

## ■ Version

It displays the current firmware version of the analyzer, executes the firmware update mode, and initializes the main unit.

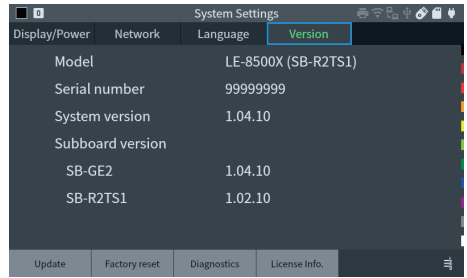

11.6 How to update the firmware



11.5 Factory reset

## 2.2.5 Diagnostics function

---

Diagnostics function checks the conditions of analyzer. After the diagnostics, the power of analyzer need to be turned off

[Preparation]

Remove all measurement cables from analyzer and save important data.



To check the GPS function, place the GPS antenna nearby the window.

[Execution]

Press [Menu] -> "System menu" -> "Version" -> "Diagnostics".

Follow the description on the screen, such as checking the LED lightning and pressing all keys.

If the diagnostics complete testing without any problems, "OK" will be displayed on the bottom of screen.

Result of diagnostics:

SD Card/USB Memory: If there is not any storage device inserted in the analyzer, "No Device" will be displayed.

GPS: It is only displayed when selecting "OK" while in the process of diagnostics (otherwise, "Skip" will be displayed). If receiving the information of time from GPS antenna within 10 minutes, "OK" will be displayed.

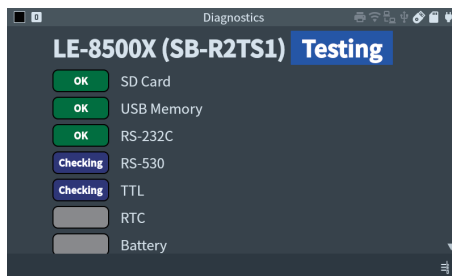

"OK" or "NG" will be displayed as the results of diagnostics. If "NG" is displayed, the analyzer may need to be repaired.



11.8 Warranty and After service

## 2.2.6 Time Settings

---

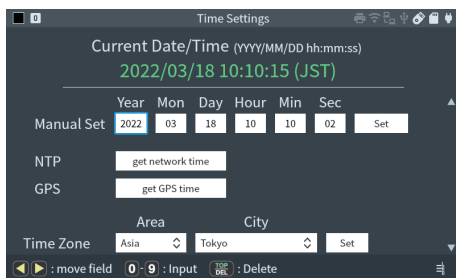

Current time and date are displayed in the screen.

Set the time in order of Hr(24hour)/Min/Sec, and date in order of Yr/Mon/Day.

- Manual Set

Manually set the date and time. Use [ ◀ ] [ ▶ ] to move the cursor, use [0] to [9] to enter, and press “Set” to confirm.

- NTP

Set the current time using an NTP server on the Internet. You need to set the network settings so that it can use Internet communication.

 2.2.4 System Config

- GPS

Set the current time using GPS. The GPS antenna must be connected. When the setting fails, move the antenna to a location with good reception, then wait a while, and try again.

- Time Zone

Specify the time zone.

-  Information of time and date is used for time stamp and Auto start/stop. Make sure to input the current time and date precisely.

## 2.3 Measurement Port

Select and set the measurement port to use.

The settings are common to all modes. Select “Interface” from the top menu screen.

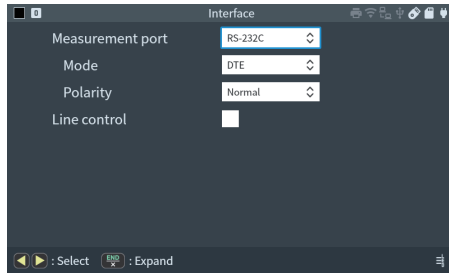

Select the measurement port of target device.

- Also it is able to select the item by [ ◀ ], [ ▶ ] and change the setting by [ ▲ ], [ ▼ ].
- Setting items are different for optional expansion boards.

### ■ Measurement Port

Select “RS-232C” for RS-232C interface, and select “RS-422/485/530” for RS-422/RS-485 and RS-530 interfaces. For TTL interface, select “TTL(xxxV)” according to the signal voltage.

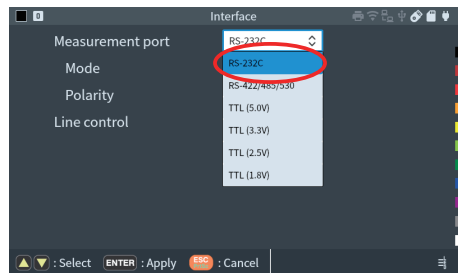

- When RS-232C, RS-422/485/530 is selected

### ■ Mode

Select the signal input/output specifications (DTE/DCE) of the measurement port when using simulation mode or BERT mode. The signal input/output specifications of the RS-232C port, RS-422/485 port, and RS-530 port during RUN are switched according to the selection. The signal input/output of the TTL port does not change.

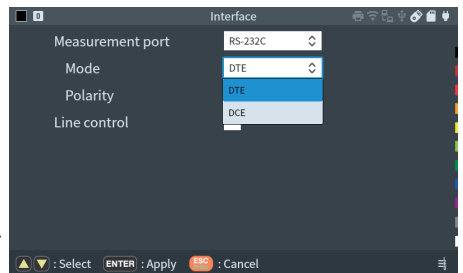

When the simulation mode or BERT mode is not running (during STOP), or when it is in the monitor function, all measurement port signals are in the input state regardless of this setting.

- In general, data terminal equipment such as PC and communication terminals are DTE specifications, and data circuit-terminating equipment such as modems and terminal adapters are DCE specifications.

- Polarity

Select “Normal”. If selecting “Invert”, all signals are inverted.

- Driver control (for RS-422/485 only)

Select Off/Manual/Auto of driver IC control for simulation.



4.2 RS-422/485 Driver Control

- V.35 mode (RS-422/485/530 only)

Check to enable only when measuring the V.35 interface using the V.35 monitor cable “LE-25M34”.



11.2 Signal Definition of the Measurement Ports

- Half-duplex Mode (sim.) (RS-422/485/530 only)

This item can only be set in normal mode. You can control the display of monitor results during RS-485 half-duplex simulation. If checked, the data sent by this unit will be displayed on the TXD side, and the received data will be displayed on the RXD side in the case of “DTE”.

In the case of “DCE”, transmit data is displayed on the RXD side, and received data is displayed on the TXD side.

- Half-duplex mode (RS-422/485/530 only)

This item can be set only in high-speed mode. When not checked, the data is displayed on the TXD side and RXD side corresponding to the input data line. When checked, only the data lines in the table below are imported.

Function	Pin mode	Data line to be taken
Online (Monitor)	DTE	TXD
	DCE	TXD
Manual (Simulation)	DTE	TXD
	DCE	RXD

- line control

This item can only be set in normal mode.

Set ON/OFF of auto line control and timing of data transmission for simulation.



4.3 Auto Line Control

○ For TTL

- Output type

Select the output type of TTL signals for simulation.

“Pull-up” : With pull-up resistor of open collector.

“No pull-up” : Without pull-up resistor of open collector.

“CMOS” : CMOS push-pull output.

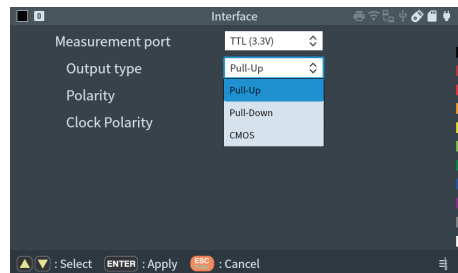

- Polarity

Select “Normal”. If selecting “Invert”, all signals are inverted.

- Clock polarity

Select the polarity of clock signal. If selecting “Invert”, all signals are inverted.

Even if you change the polarity or clock polarity setting items, the timing waveform display will not be reversed.



6.3 Timing Waveform Measurement Function

## 2.4 Communication Condition Settings

Select “Configuration” from the top menu screen. On the displayed screen, set the basic communication conditions according to the communication conditions to be tested.

Tap each item to select it, or enter it with the [0] to [F] and [X] keys.

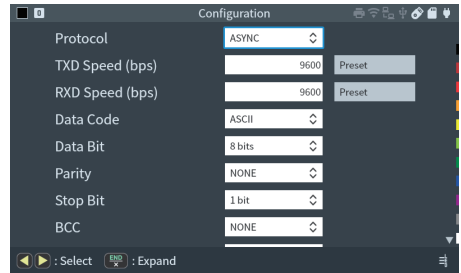

There is no setting in Delay mode.

A function to automatically set communication conditions is available.

6.4 Auto Configuration Function

### Protocol

Touch “Protocol” and select the protocol of target devices. ASYNC (asynchronous communication) is commonly used.

There is a difference in the protocols that can be used in normal mode and fast mode.

2.2.1 Switching between normal mode and high-speed mode

#### ■ Protocol

Selection	Protocol	Description
ASYNC	Asynchronous	Communication which uses the start and stop bit. Ex.) PC COM port, UART communication.
SYNC/BSC <sup>*1</sup>	Character-SYNC	Communication which uses 1 or 2 bytes of SYNC characters. Ex.) BSC, JCA procedure etc.
HDLC/SDLC	Flag-SYNC	Communication which uses the flag bit patterns (7Eh). Ex.) HDLC, SDLC, X.25, LAPD
ASYNC - PPP <sup>*1</sup>	PPP (ASYNC typed)	Asynchronous which uses flag characters 7Eh). Ex.) ASYNC-PPP communication used for WAN etc.
I2C <sup>*1</sup>	I2C	Communication which uses 2 lines (SDA and SCL) at TTL level.
Burst <sup>*1</sup>	Clock-Sync	Communication which has the Sync-clock only when transmitting/receiving data.
SPI	SPI	Communication which uses 3 (or 4) lines at TTL level.
MODBUS <sup>*1</sup>	MODBUS (ASCII/RTU)	Asynchronous communication standard often used for communication between factory automation devices
PROFIBUS	PROFIBUS-DP	Fieldbus for factory automation.
I3C <sup>*2</sup>	MIPI I3C Basic	Next-generation chip-to-chip communication by enhanced I2C

\*1 Cannot be used in high-speed mode.

\*2 Can only be used in high-speed mode. (Requires system version 1.15 or later.)



## Communication Speed

Set the communication speed of target devices. For simulation function, it is able to check the tolerance of target device by setting the different speed on purpose.

- TXD speed  
Set the communication speed of transmission line. After setting this, RXD speed is automatically set.
- RXD speed  
Set the communication speed of receiving line.
- Speed  
Set the communication speed for I2C, SPI, MODBUS and PROFIBUS.

📄 I3C and Burst are for synchronous monitoring only, so there is no communication speed setting.

Tap “Preset” to display a list of communication speeds that are commonly used, and you can select and set it from the list.

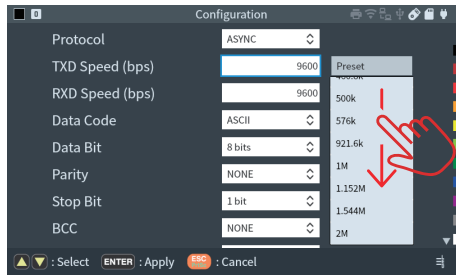
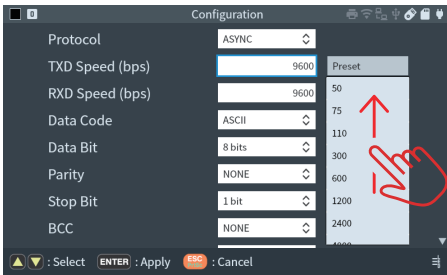
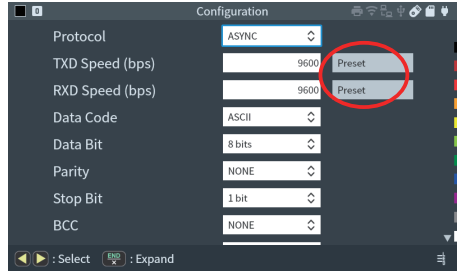

## Arbitrary Speed

Appointed communication speed can be set to 4 figures as effective numbers. Speed: [0] to [9] key, Decimal point: [C] key, Kilo: [D] key, Mega: [E] key.

Exp.: To set “945.6kpbs”,  
input [9] [4] [5] [C] [6] [D].

📄 Press [◀], [▶] to increase/decrease the speed.

📄 It can be set from 50bps to 12Mbps for the normal mode and can be set from 50bps to 20Mbps (30Mbps for SPI only) for the high-speed mode.

📄 When selecting the RS-232C port, set 1Mbps or less.

📄 For I2C set it to 3.4Mbps or less.

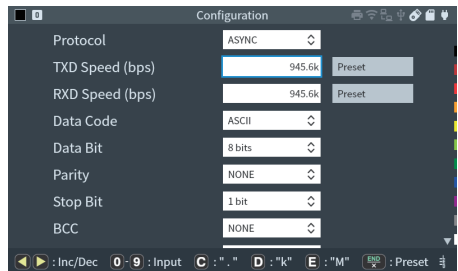



## Details of Each Protocol Setting

Each protocol has different settings.

### ○ ASYNC

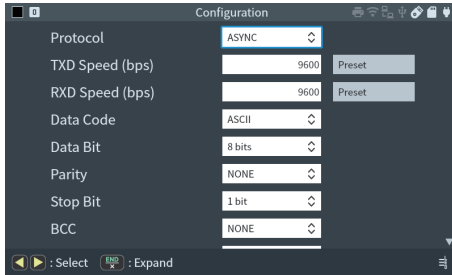

#### ■ Data code

Select a data code from ASCII, EBCDIC, EBCDIK, JIS, EBCD, Transcode, IPARS, Baudot and HEX.

For some data codes, it changes the character by SHIFT control.

☰ “JIS7” and “JIS8” are automatically changed by setting of “Data bit”.



10.4 Data Code Chart

#### ■ Data bit

Set a data bit length. Only the bit length allowed for each data code can be set.

#### ■ Parity

Set a parity bit and a MP (multi-processor) bit.

☰ MP is the 1 bit of transmission information adding after data bit.

☰ Parity bit is always 1 for “Mark” and 0 for “Space”.

#### ■ Stop bit

Set a stop bit length. Stop bit is added to transmissions data during simulation.  
(For received data, stop bit is always 1 bit.)

#### ■ BCC

Set a block check code. If “None” is set, block check is not executed.

Selection items of BCC are changed by total bit of data bit and parity bit.



10.1 Calculation of the Block Check

#### ■ Begin code

Set a calculation start code for block check in HEX. As a factory setting, “01h, 02h” is already set.

Higher bits than a bit length set on “Data bit” are invalid.

■ End code

Set the block error check calculation end character in hexadecimal. 03h and 17h are preset at the time of shipment. Please note that bits higher than the data bit length set in “Data bit” are regarded as invalid.

■ ITB code

Set the ITB character used for block error check in hexadecimal. 1Fh is preset at the time of shipment. Please note that bits higher than the data bit length set in “Data bit” are regarded as invalid.

■ Transparent mode

Check when measuring in transparent mode.

■ DLE code

Set the DLE character in hexadecimal when transparent mode is checked. 10h is preset at the time of shipment.

■ Bit sequence

Set a bit sequence. For general protocols, select “LSB first”.

< Example of LSB first >

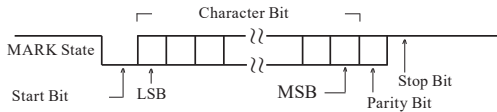

< Example of MSB first >

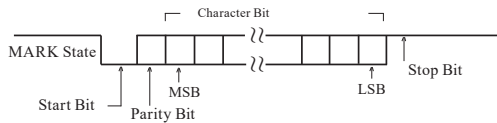

■ Frame end time

Set the time of non-communication state which is judged as a frame end at between 1ms and 100ms.

Initial value is 5ms.

📖 This setting is necessary to record time stamp.

📖 Set the frame end time to be smaller than idle time.

■ Frame end code

Set a frame end code (1 or 2 characters) in HEX.

📖 Initial setting is “blank”. If setting nothing in here, frame end is judged by “Frame end time”.

## ○ SYNC/BSC (Character SYNC)

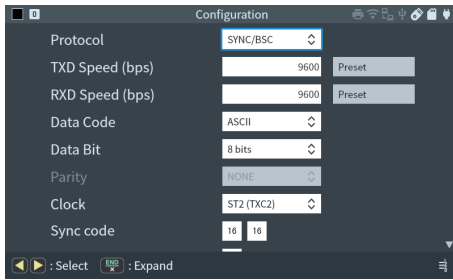

### ■ Data code

Same as ASYNC.

10.4 Data Code Chart

### ■ Data bit

Set a data bit length. Only the bit length allowed for each data code can be set.

Total bit of data bit and parity should be 6 or 8.

### ■ Parity

Set a parity bit.

### ■ Clock

Select a SYNC-clock to receive/transmit communication data. Select “AR” if the SYNC-clock is uncertain or using the RS-422/485 port which has no clock line.

10.2 Send/Receive Clock

### ■ SYNC code

Set a SYNC-character (1 or 2) in HEX. The initial value is “16h, 16h” which is often used in ASCII and JIS. (“32h, 32h” for EBCDIC and EBCDIK)

Higher bits than a bit length set on “Data bit” are invalid. If setting the parity bit, character with parity is the target to establish synchronization. For example, if setting “Data bit: 7”, “Parity: even”, “SYNC code: 1616 or 9696”, synchronization is established when receiving “96h, 96h”. (not receiving “16h, 16h”)

### ■ Reset code

Set a reset code in HEX. The initial value “FFh” and it is not necessary to change the values in most of the cases.

Higher bits than a bit length set on “Data code” are invalid.

### ■ Reset repeat

Set the number of synchronous release codes for SYNC/BSC. Synchronization is released when synchronization release characters are received consecutively for the number of times set here.

Normally, it is used with “Synchronous release code” = “FF” and “Synchronous release code received count” = “2” (default).

When 'data bit' = '8', if the mark status (1) continues for 16 bits or more, it determines that the frame has ended.

■ Suppress code

Set a suppress code in HEX. When codes set in this section are monitored continuously, the second byte and after ones are not recorded in the capture buffer.

■ BCC

Same as ASYNC.

■ Bit sequence

Set a bit sequence. For general protocols, select “LSB first”.

■ Format

Select an encoding type from “NRZ” or “NRZI”. The initial setting is “NRZ”.

○ HDLC / SDLC

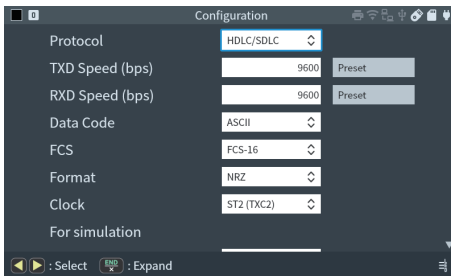

■ Data code

Select a data code from ASCII, EBCDIC, EBCDIK, JIS and HEX.

10.4 Data Code Chart

■ FCS

This item can only be set in normal mode.

Select a frame checking sequence (error check) type from “None”, “FCS-16” or “FCS-32”.

10.1 Calculation of the Block Check

■ Format

Select an encoding type from “NRZ”, “NRZI”, “FM0”, “FM1”, “Manchester0” or “Manchester1”.

“NRZI” is also used if the clock is “AR”.

In high-speed mode, select from “NRZ” or “NRZI”.

■ Clock

This item can only be set in normal mode.

Select a SYNC-clock to receive/transmit communication data. Select “AR” if the SYNC-clock is uncertain or using the RS-422/485 port which has no clock line.

10.2 Send/Receive Clock

■ Idle mode for simulation

Select an idle state (“Mark” or “Flag”) between frames.

- Idle mode for simulation

Select an idle state (“Mark” or “Flag”) between frames.
- Leading flag for simulation

Set the number of transmission starting flags from 1 to 10. The initial value is 1.

 When phase-aligning the receive clock with data in normal mode, multiple flags must be output for synchronization alignment.
- TXD address of address filter (pass)

This item can only be set in normal mode.

Set a frame address (8 bits after a flag) on the TXD(SD) side in HEX to receive related frames.

To receive all frames, set “\* (don’t care)”. Initial setting is “ \* ”.
- RXD address of address filter (pass).

This item can only be set in normal mode.

Set a frame address (8 bits after a flag) on the RXD(RD) side in HEX to receive related frames.

To receive all frames, set “\* (don’t care)”. Initial setting is “ \* ”.

 The address filter has no effect on the data sent by the analyzer in the simulation function.
- ID filter TXD address 1, TXD address 2

This item can be set only in high-speed mode.

Set the filter for the first and second receive data on the TXD side in bit units (0, 1, \* (don't care)).
- ID filter RXD address 1, RXD address 2

This item can be set only in high-speed mode.



Set the filter for the first and second receive data on the RXD side in bit units (0, 1, \* (don't care)).
- Frame of Translation protocol (Initial)

Sets the specification of frame-level translation display. The default is X.25.
- Packet of Translation protocol (Initial)

Sets the specification of packet-level translation display. The default is X.25.

 10.5 Translation Display Specification

< About ID filter >

-  If don't care is set to all the items, all frames are monitored.
-  Frames that do not match the ID filter settings are not monitored during online monitoring.
-  In simulation mode, when “half-duplex mode (sim)” is unchecked in the interface settings, all frames transmitted by the analyzer will be monitored regardless of the ID filter settings. When checked, only frames that match the ID filter settings will be monitored. Also, by setting don't care on only one side of the ID filter (TXD side or RXD side), the received frames can be displayed separately on the TXD side and the RXD side.

Half-duplex Mode	ID Filter Setting	Monitor Screen Display
Invalid	Don't care settings for both TXD and RXD addresses	TxD is displayed on the TXD side and RxD is displayed on the RXD side.
	Set all RXD addresses to don't care, TXD addresses to non-don't care	Only those that match the ID filter of TxD are displayed on the TXD side. All RxD is displayed on the RXD side.
	Set all TXD addresses to don't care, RXD addresses to non-don't cares	All TxD is displayed on the TXD side. Only those that match the RxD ID filter are displayed on the RXD side.
	Set both TXD and RXD addresses to anything other than don't care	Only those that match the ID filter of TxD are displayed on the TXD side. Only those that match the ID filter of RxD are displayed on the RXD side.
Valid	Don't care settings for both TXD and RXD addresses	All TxD is displayed on the TXD side.
	Set all RXD addresses to don't care, TXD addresses to non-don't care	Only those that match the ID filter of TxD are displayed on the TXD side. Displays the non-match ones on TXD side.
	Set all TXD addresses to don't care, RXD addresses to non-don't cares	Only those that match the ID filter of TxD are displayed on the RXD side. Displays the non-match ones on TXD side.
	Set both TXD and RXD addresses to anything other than don't care	Only those that match the ID filter of TxD are displayed on the TXD side. Only those that match the ID filter of RxD are displayed on the RXD side.

(Example) Monitor screen display when “half-duplex mode” is enabled and the ID filter is set as follows:

TXD Address 1: 00110000 (30h)

RXD Address 1: \*\*\*\*\* (Don't care)

TXD Address 2: 00110001 (31h)

RXD Address 2: \*\*\*\*\* (Don't care)

Frame on TxD line



TXD side monitor screen display

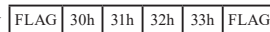

RXD side monitor screen display

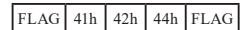

(Example) Monitor screen display when “half-duplex mode” is disabled (full-duplex) and the ID filter is set as follows:

TXD Address 1 : 00110000(30h)

RXD Address 1 : 0100\*\*\*\*

TXD Address 2 : 00110001(31h)

RXD Address 2 : \*\*\*\*\* (Don't care)

Frame on TxD line



Frame on RxD line



TXD side monitor screen display

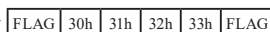

RXD side monitor screen display

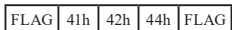

## ○ ASYNC-PPP

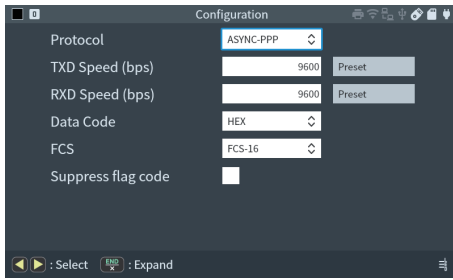

### ■ Data code

Select a data code from ASCII, EBCDIC, EBCDIK, JIS and HEX.

When selecting “ASYNC-PPP”, it automatically sets “Data bit: 8”, “Parity: none” and “Stop bit: 1”.

 10.4 Data Code Chart

### ■ FCS

Select a frame checking sequence (error check) type from “None”, “FCS-16” or “FCS-32”.

 10.1 Calculation of the Block Check

### ■ Suppress flag code

When the flag character (7Eh) is monitored continuously, the second byte and after ones are not recorded in the capture buffer.

## ○ I2C

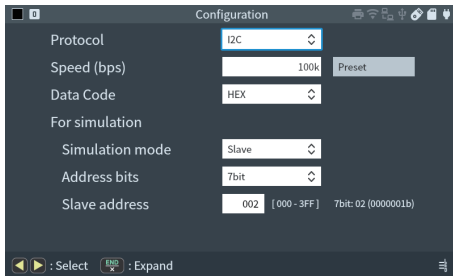

Set the speed below 1Mbps for simulation.

### ■ Data code

Select a data code from ASCII, EBCDIC, EBCDIK, JIS, and HEX.  
Select “HEX” for general use. (initial setting is HEX)

### ■ Simulation mode

Select “master” or “slave” for I2C simulation.

### ■ Address bits

Set the number of address bit of analyzer during slave simulation.

■ Slave address

Set the address of analyzer in HEX during slave simulation.

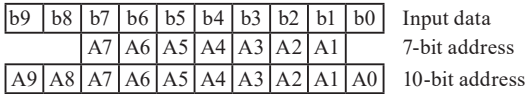

(Exp.) Input 123 (0100100011b)  
 7-bit address is “0010001” 10-bit address is “0100100011”

📖 For I2C protocol, select “TTL(5.0V)~TTL(1.8V)” from “Interface”->“Measurement port”, and select “No pull-up” or “Pull-up” (target device does not have a pull-up resistor) for “Output type”.

○ SPI

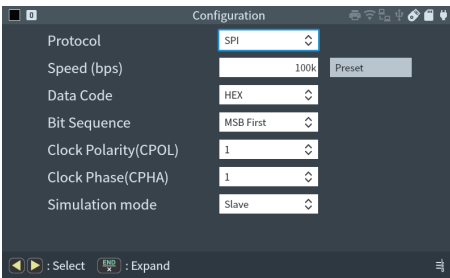

■ Data code

Select a data code from ASCII, EBCDIC, EBCDIK, JIS, and HEX.  
 Select “HEX” for general use. (initial setting is HEX)

📖 10.4 Data Code Chart

■ Bit sequence

Select a bit sequence.

■ Clock polarity

Set the polarity of SPI clock.

■ Clock phase

Set a topology of SPI clock.

<Timing of SPI clock and data>

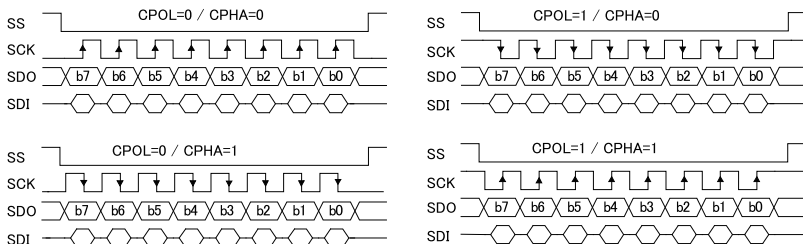

■ Frame end time

This setting is necessary only for high-speed mode.

Set the SPI frame end time (resolution: 0.1 μs). In the case of SS signal is not changed every frame, it is recognized as the frame end when clock signal has not changed during the set time. If “0” is set, frame end setting is invalid.

■ Simulation mode

Select “Master” or “Slave” mode for SPI simulation. I/O direction of SS signal and SCK signal of TTL port are changed according to the “Master/Slave” selection.

☞ In slave mode simulation, a certain delay occurs in the transmitter/receiver circuit of this unit, so depending on the cable length and operating voltage, it may not be possible to communicate properly if the clock on the master side is approximately 15MHz or higher..

☞ Set “Port” of “Interface” to be “TTL(5.0V) ~ TTL(1.8V)” and “output type” to be “CMOS” for SPI protocol.

○ Burst

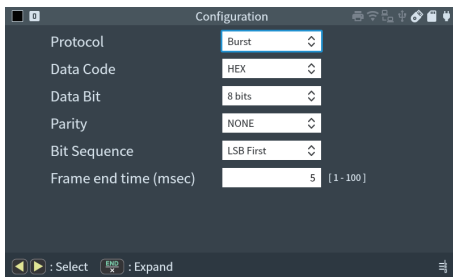

■ Data code

Select a data code from ASCII, EBCDIC, EBCDIK, JIS, and HEX.

📖 10.4 Data Code Chart

■ Data bit

Set a data bit length. (7 or 8)

■ Parity

Set a parity bit.

■ Bit sequence

Select a bit sequence.

■ Frame end time

Set the time (1 ~100ms) of non-communication state which is judged as a frame end. The initial value is 5ms.

☞ This setting is valid only for monitoring of Burst protocol.

☞ For Burst protocol, select “TTL(5.0V) ~TTL(1.8V)” from “Interface”->“Measurement port”.

## ○ MODBUS

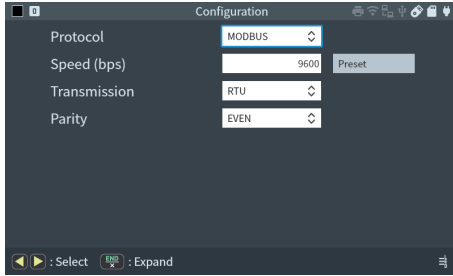

### ■ Transmission

Select a transmission mode from “ASCII” or “RTU”.

📄 RTU: If there is a frame with 3.5 characters or more of silent interval (non-communication time), the last second byte is recognized as CRC error check code. Data structure of ASCII: Begin code (“:”(3Ah), + Data (“0”(30h) ~ “9”(39h), “A”(41h) ~ “F”(46h)), + End code (“CR”, “LF”(0Dh, 0Ah)).

### ■ Parity

Set a parity bit.

📄 For Modbus protocol, it automatically set to 10 bit ASYNC communication. Data bit (8), parity (0 or 1) and stop bit (1 or 2).

## ○ PROFIBUS

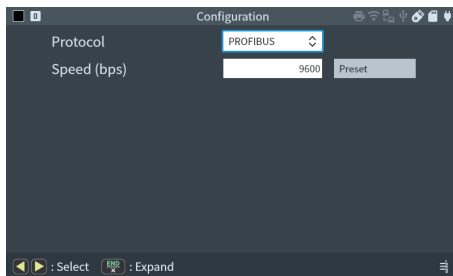

There is not any specific setting.

## ○ I3C

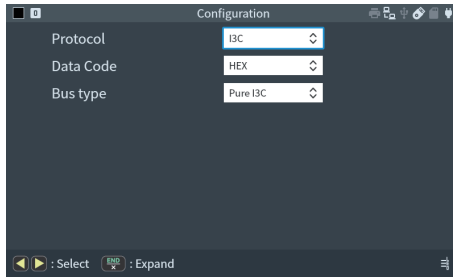

### ■ Data code

Select a data code from ASCII, EBCDIC, EBCDIK, JIS, and HEX.

Select "HEX" for general use. (initial setting is HEX)

### ■ Bus Type

Selecting "Pure I3C" it monitors all frames as I3C communication.

Selecting "I3C/I2C Mixed" it assumes that frames with an address other than 7'h7E and an SCL H pulse width longer than a certain threshold are I2C communication, and interprets the 9th bit of the data portion as an ACK/NACK.

Select "Pure I3C" if only I3C devices exist on the bus. Select "I3C/I2C Mixed" if I2C devices (I2C communication) are also present on the bus.

☰ To select the I3C protocol, switch the unit to high-speed mode.

☰ When using the I3C protocol, only the monitor function is available.

☰ When using the I3C protocol, set the "Measurement Port" in "Interface" to "TTL (5.0V) - TTL (1.8V)."

## 2.5 Connection



### Connect to RS-232C

To measure RS-232C, select “RS-232C” from “Interface” -> “Measurement port”.



2.3 Measurement Port

■ For monitoring

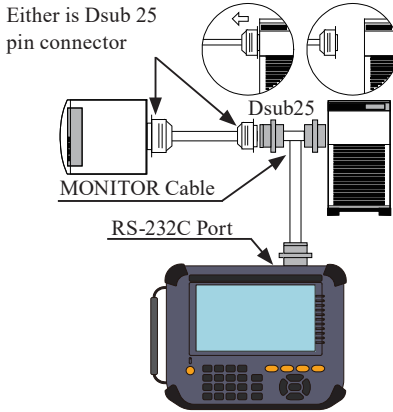

If the connector of either target device is Dsub 25 pin, use attached DSUB 25 pin monitor cable (LE-25M1) to connect to the analyzer.

[ Connection of LE-25M1 ] ( ) is the pin number .

Dsub25pin male	Dsub25pin male	Dsub25pin female
( 1 ) -----	( 1 ) -----	( 1 )
( 2 ) -----	( 2 ) -----	( 2 )
( 3 ) -----	( 3 ) -----	( 3 )
( 4 ) -----	( 4 ) -----	( 4 )
.		
.	( connected to the same numerical pin )	
.		
( 24 ) -----	( 24 ) -----	( 24 )
( 25 ) -----	( 25 ) -----	( 25 )

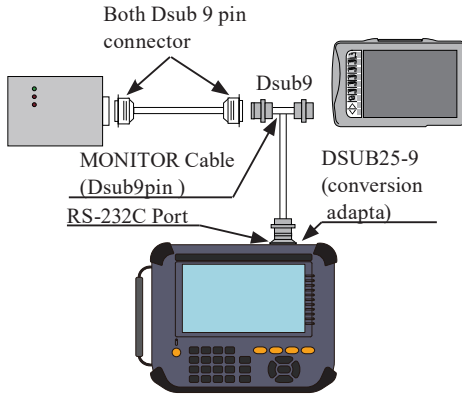

If the connectors of both target devices are Dsub 9 pin, use attached DSUB 9 pin branch cable (LE009M2) and DSUB 25-9 conversion adapter to connect to the analyzer.

[ Connection of LE-009M2 and DSUB25-9 adapter ] ( ) is the pin number.

DSUB25-9 adapter		LE-009M2	
Dsub25pin male	Dsub9pin male female	Dsub9pin female	Dsub9pin male
( 8 )	----- ( 1 )	----- ( 1 )	----- ( 1 )
( 3 )	----- ( 2 )	----- ( 2 )	----- ( 2 )
( 2 )	----- ( 3 )	----- ( 3 )	----- ( 3 )
( 20 )	----- ( 4 )	----- ( 4 )	----- ( 4 )
( 7 )	----- ( 5 )	----- ( 5 )	----- ( 5 )
( 6 )	----- ( 6 )	----- ( 6 )	----- ( 6 )
( 4 )	----- ( 7 )	----- ( 7 )	----- ( 7 )
( 5 )	----- ( 8 )	----- ( 8 )	----- ( 8 )
( 22 )	----- ( 9 )	----- ( 9 )	----- ( 9 )

■ For Simulation

Connect analyzer and target device one by one. Connect as following, concerning the specification of target device (DTE/DCE) and RS-232C cable.

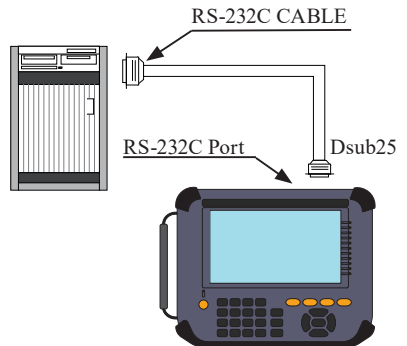

DTE device	-----	Straight cable	-----	Analyzer (DCE setting)
DCE device	-----	Straight cable	-----	Analyzer (DTE setting)
DTE device	-----	Cross cable	-----	Analyzer (DTE setting)
DCE device	-----	Cross cable	-----	Analyzer (DCE setting)

## Connect to RS-422, RS-485

To measure RS-422/485, set “Measurement port: RS-422/485” at “Interface” setting.

### 2.3 Measurement Port

If the RS-422/485 connector (or terminal block) of target device uses unique specification, check the signal assignment carefully. And then connect to attached RS-422/485 terminal block of analyzer using appropriate cables. Remove this terminal block from the analyzer first and then connect the cables.

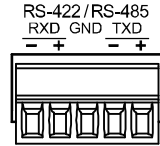
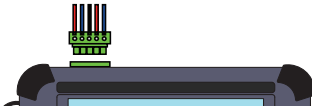
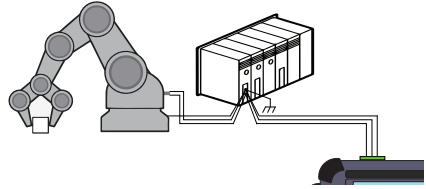

Connect SG (signal ground) of target device and SG of analyzer certainly.

#### RS-422 Monitoring

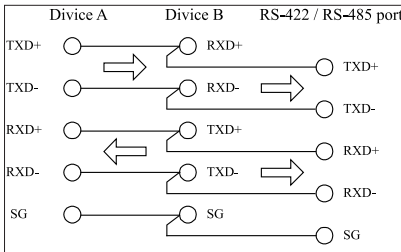

#### RS-422 Simulation

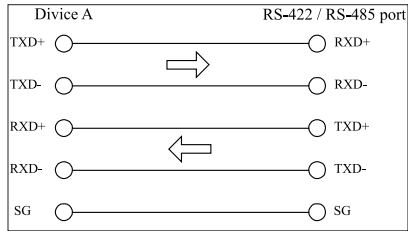

#### RS-485 Monitoring/Simulation

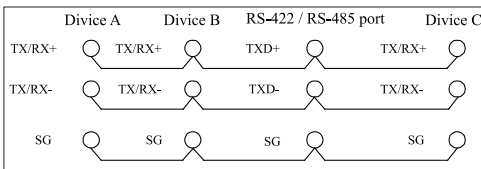

To measure RS-485 half-duplex, the analyzer is connected as one of the RS-485 nodes.

If the analyzer is connected as left figure, set the analyzer to be “DTE” for simulation.

If the analyzer is placed on the termination of the line (without equipment C on left figure), set “on” the termination resistance of TXD for RS-422/485 port.

The transmit/received data are measured on TXD on the analyzer.

For RS-485 half-duplex data, the analyzer cannot recognize which data come from equip A or B and monitor both data on TXD. To distinguish them, add time stamp to have the end of frame.



Set “port” to be “RS-422/485/530” in the “Interface” setting.

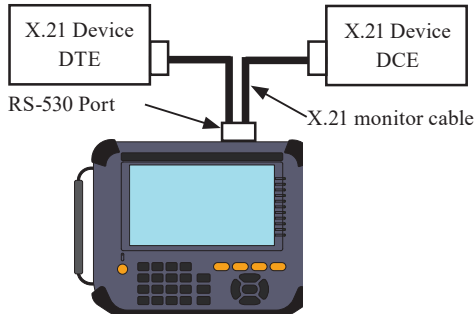

Various legacy serial protocols are able to monitor by using the following optional cables. Also, use this port to measure RS-422 line with control signals such as RTS and CTS.

Option Name	Model	Description
X.21 monitor cable	LE-25Y15	DSUB 15pin, Y branch, for X.20/21
RS-449 monitor cable	LE-25Y37	DSUB 37pin, Y branch, for RS-449
V.35 monitor cable	LE-25M34	M type 34pin, Y branch, for V.35
RS-530 cable	LE-25S530	DSUB 25pin, for RS-530
Terminal block for DSUB 25 pins LE-25TB	LE-25TB	All the signals of DSUB 25pins can be taken from the 25pin terminal block

#### ■ Terminal resistance

When this unit is the end of the line, remove the interface sub-board from the main unit, turn on the DIP switch, and connect the 120 Ω terminating resistor.

Switch Number	Signal Name	Switch Number	Signal Name
1	TXD	6	RTS
2	TXC1	7	DTR
3	RXD	8	CTS
4	RXC	9	DSR
5	TXC2	0	DCD

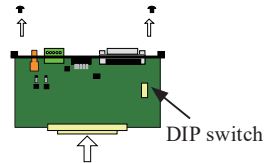

\* All switches are turned off as the factory setting.



Turn ON all terminal controls when you test with the RS-530 cable.  
Turn OFF all terminal controls when you test with the X.21/RS-499/V.35 monitor cables.  
Turn ON the terminal control, if there is not any terminal control on the target devices (if it is easily affected by noise).

## Connect to TTL

To measure UART, I2C and SPI, set “Measurement port: TTL (5.0V) ~(-1.8V)” at “Interface” setting.

### 2.3 Measurement Port

Connect appropriate signals to the TTL port of analyzer using the attached 5-line TTL probe cable (model: LE5LS).

TTL port is 2.54mm pitch 10 pin MIL box type connector. Use the one equivalent to “HIF3FC-10PA-2.54DS(71)” of HIROSE Electric. Co., Ltd.

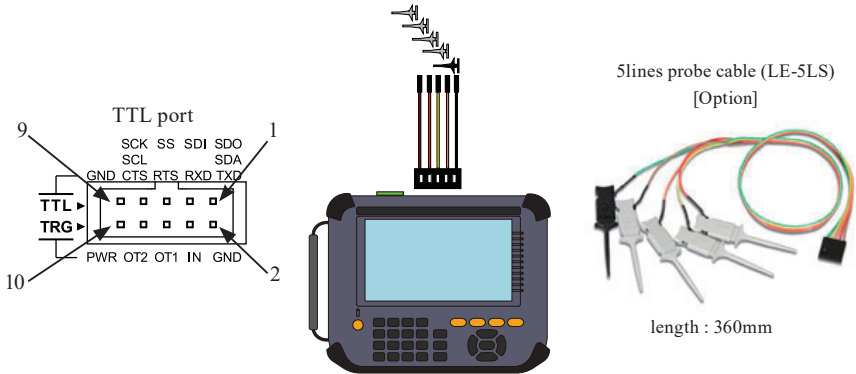

< Example of connection for ASYNC >

Signal	Pin No.	Lead wire	Input/Output		Signal of target device	
			Monitor	Simulation	Monitor	Simulation
TXD	1	Brown	I	O	TXD	RXD
RXD	3	Red	I	I	RXD	TXD
RTS	5	Orange	I	O	RTS	CTS
CTS	7	Yellow	I	I	CTS	RTS
GND	9	Green	-	-	Signal GND	Signal GND

< Example of connection for SYNC/HDLC >

Signal	Pin No.	Lead wire	Input/Output		Signal of target device	
			Monitor	Simulation	Monitor	Simulation
TXD	1	Brown	I	O	TXD	RXD
RXD	3	Red	I	I	RXD	TXD
TXC <sup>*1</sup>	5	Orange	I	I/O <sup>*3</sup>	TXC	RXC
RXC <sup>*2</sup>	7	Yellow	I	I	RXC	TXC
GND	9	Green	-	-	Signal GND	Signal GND

\*1 : If the setting of configuration clock is “AR”, it works as the RTS.

\*2 : If the setting of configuration clock is “AR”, it works as the CTS.

\*3 : It depends on the setting of configuration clock.

O: ST1 (TXC1), I: ST2 (TXC2).

< Example of connection for I2C >

Signal	Pin No.	Lead wire	Input/Output		Signal of target device	
			Monitor	Simulation	Monitor	Simulation
SDA	1	Brown	I	I/O	SDA	SDA
SCL	7	Yellow	I	I/O	SCL	SCL
GND	9	Green	-	-	Signal GND	Signal GND

< Example of connection for I3C >

Signal	Pin No.	Lead wire	Input/Output		Signal of target device	
			Monitor	Simulation	Monitor	Simulation
SDA	1	Brown	I	-	SDA	-
SCL	7	Yellow	I	-	SCL	-
GND	9	Green	-	-	Signal GND	-

< Example of connection for SPI >

Signal	Pin No	Lead wire	Input/Output		Signal of target device	
			Monitor	Simulation	Monitor	Simulation
SDO	1	Brown	I	I/O	MOSI	MISO
SDI	3	Red	I	I	MISO	MOSI
SS	5	Orange	I	I/O	SS	SS
SCK	7	Yellow	I	I/O	SCK	SCK
GND	9	Green	-	-	Signal GND	Signal GND

< Example of connection for Burst >

Signal	Pin No	Lead wire	Input/Output		Signal of target device	
			Monitor	Simulation	Monitor	Simulation
TXD	1	Brown	I	-	TXD	-
RXD	3	Red	I	-	RXD	-
SCK	7	Yellow	I	-	SCK	-
GND	9	Green	-	-	Signal GND	-

## 2.6 Connection and Setting of Time stamp Synchronous Function

The timestamp synchronization feature has the following connections.

 2.2.3 Record Control

### ■ Synchronize by GPS antenna

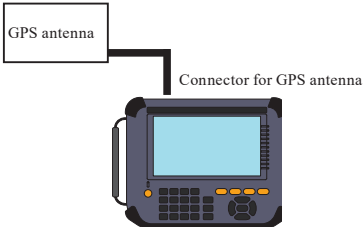

Synchronizes the LE-8500X-RT's time stamp using a GPS active antenna.

Then optional GPS active antenna is needed.

Set "GPS time" to "Synchronization" on LE-8500X-RT.

### ■ Share GPS antenna with two units

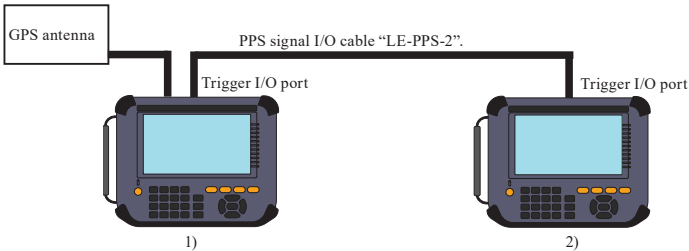

Synchronizes the time stamps of two LE-8500Xs with one GPS active antenna.

It is necessary to have the optional GPS active antenna and PPS signal I/O cable "LE-PPS-2".

Set "Synchronization" setting of Device 1) to be "GPS time".

Set "Synchronization" setting of Device 2) to be "Ext.PPS (TRG IN)".

Remove the check mark of "Invert polarity".

 Do not connect the GPS antenna to 2).

### ■ Synchronize by External PPS signal output device

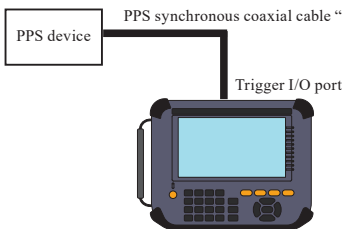

Time stamp information is synchronized with the external PPS signal output device.

It is necessary to have the optional PPS synchronous coaxial cable "LE-SMA-LS-2".

Set "Time stamp synchronous" setting to be "Ext. PPS (TRG IN)".

Select "Invert polarity" setting according to the PPS signal output device.

 Do not connect the GPS antenna.

# Chapter 3 Monitor Function

## 3.1 Online Monitoring (ONLINE)

The monitor function records measured data in the capture buffer without impacting on a communication channel.

Also, it displays data clearly following each communication protocol. Not only communication data but also the time stamp and idle time are recorded. As a result, error time and time out conditions can be investigated.

Select “Mode” -> “Online” from top menu.

Normal mode

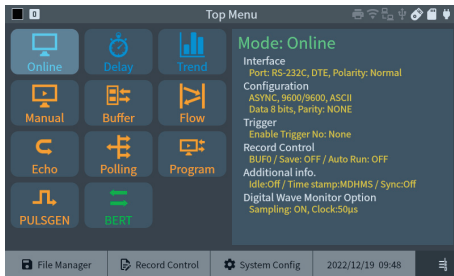

High-speed mode

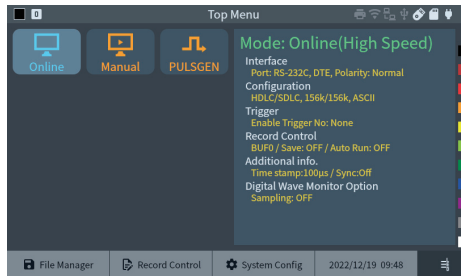

### Setting

Confirm the Interface and Configuration settings according to the target device.

Change the settings if necessary.

### 2.3 Measurement Port

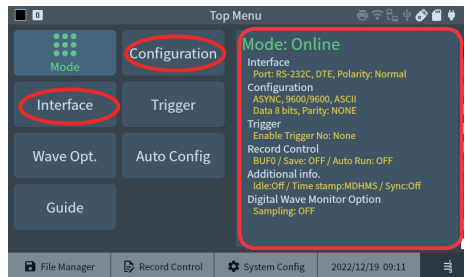



## Operation

To start measurement, press [RUN]. Then, data will be recorded in the capture buffer while displaying data on the screen. Transmission and reception data is displayed in two lines as one set. “” is the mark which indicates the place of new data.



## Stop Renewing Display

When [ESC] key or “Pause display” on the bottom of screen is pressed, the motion on the screen temporarily seems stopped while measurement has continued even after being pressed.

“Pause display” key becomes in green while it runs the operation.

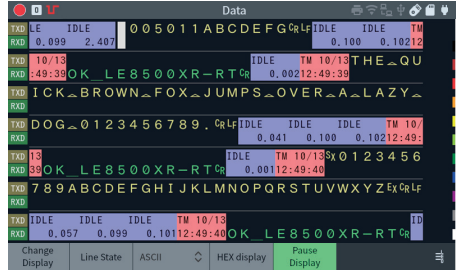





This operation will not affect trigger function or capturing data.

In order to toggle this status, press [ESC] or “Pause display” again.



## Special symbols

Errors and breaks are displayed in unique characters.

Character	Description
<b>PE</b>	Parity Error (parity bit error)
<b>FE</b>	Framing Error (stop bit is "0")
<b>PF</b>	Parity & Framing Error
<b>B</b>	Break (start bit, character bit, (parity bit), stop bit are all "0".)
<b>A</b>	Abort (7bits or more of "1" is continuously detected) <sup>(*)</sup>
<b>SF</b>	Short Frame (frame length is short)
<b>G</b>	Block check code normal (BCC or FCS is normal)
<b>E</b>	Block check code abnormal (BCC or FCS is abnormal)
	HDLC starting flag pattern (7Eh) is detected
	HDLC ending flag pattern (7Eh) is detected
	Multi processor bit or acknowledge bit of I2C is "1". (displayed in blue back) Displays the background in blue when the I3C is in NACK or Read and the T-bit is "0"
	I2C / I3C (re)start sequence is detected.
	I2C / I3C stop sequence is detected.
<b>TR</b>	When an I3C Target Reset pattern is detected
<b>HX</b>	When an I3C HDR Exit pattern is detected
<b>HR</b>	When an I3C HDR Restart pattern is detected
<b>OE</b>	When the analyzer could not process the recording.
<b>LD</b>	Cannot save all data by auto save function

\*1 :About **A** (ABORT) character on RS-485 line

On an RS-485 half-duplex line, if the line goes into a high-impedance state within 8 bit time after the completion of HDLC (NRZI) frame transmission, the line may go into the **A** state. In an actual communication system, such an ABORT frame will be discarded and no error will occur.



## Change Display Code

Once start measuring, data is displayed in selected data code set in the configuration setting. Touch the current data code (“ASCII” in the figure) to display in different data code.

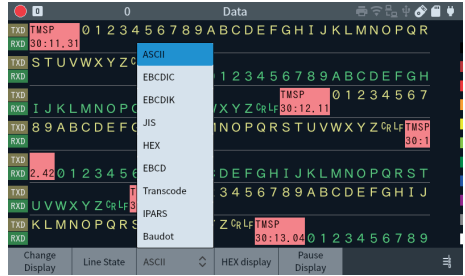

Tap “HEX display” to change the display code.

For HEX display, special characters and results of block check are also displayed in HEX.

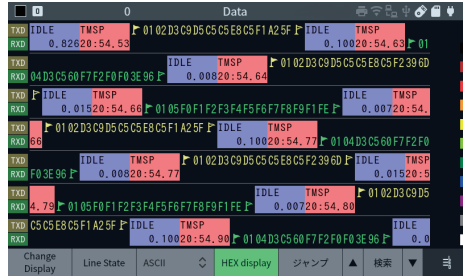

## Display Time Information

### Time Stamp

The time, when the head of character of each frame running through the communication channel is received, is recorded in the capture buffer and displayed as following.

#### For Normal mode

Day Hr: Min

TMSF  
30 14:15

Hr: Min: Sec

TMSF  
14:16:04

Min: Sec: 10ms

TMSF  
16:17.00

Yr/Mo/Day/Hr/Min

TM 92/09  
30 14:16

Mo/Day Hr:Min:Sec

TM 09/30  
14:16:39

Day Hr: Min:Sec: 10ms

TM 30 14  
16:49.40

100us

TMSF  
00001.366.3

10us

TMSF  
0001.102.60

1us

TMSF  
000.974.476

- For High-speed mode

1ms	100us	10us	1us
TMSP 000002.412	TMSP 00001.366.3	TMSP 0001.102.60	TMSP 000.974.476

- ☰ Set the resolution of time stamp in the “Record control” (additional information tab).  2.2.3 Record Control
- ☰ It consumes 4bytes to record the time stamp of “D/H/M”, “H/M/S”, “M/S/10ms” in the normal mode. And, it consumes 8 bytes for other settings and in the high-speed mode.

## ■ Idle Time

The time, when SD and RD keep non-communication status and a changeless status of signal lines, is recorded as following.

Resolution	Range	Example
100msec.	0 ~ 999.9sec.	IDLE 001.2
10msec.	0 ~ 99.99sec.	IDLE 01.23
1msec.	0 ~ 9.999sec.	IDLE 1.234

- ☰ Idle time cannot be displayed for high-speed mode.
- ☰ Set the resolution of idle time in the “Record control” (additional information tab).  2.2.3 Record Control
- ☰ Elapsed time until synchronizing in the Synch protocol and elapsed time until receiving the specific address in HDLC protocol are recognized as the idle status.
- ☰ If the time of one bit is slower than idle time (low speed communication), idle time may not be accurate.
- ☰ “OVER” is displayed if it exceeds the range.



## Change Display Format

Following data display types can be changed by “Change display” key. It will return to the “Data display”.

<Data display>

It displays raw data.



<Frame translation display>

It displays translated data set in the “protocol translation display”.



Protocol Translation Display

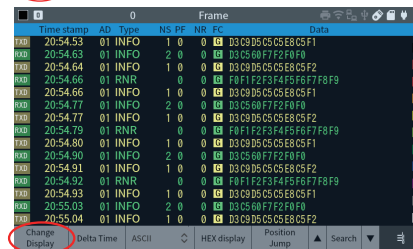

<User defined translation display>

It is appeared if “Translation Definition” is selected in the “Display Control”.



6.6 Translation Function

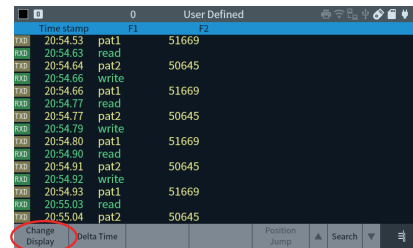

<Timer/Counter>

It displays the timer/counter value used in the trigger and program simulation function.



Display of timer/counter value

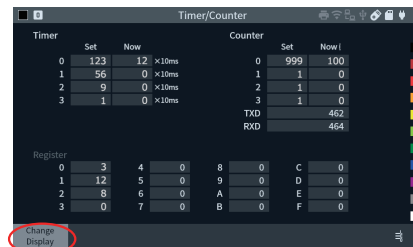

<Timing waveform display>

It is displayed if “Enable wave monitor” is selected in the “Wave Opt.”.



6.3 Timing Waveform Measurement Function

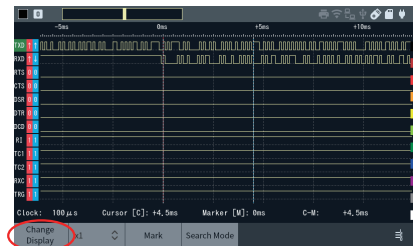



## Line state display

Status of control lines (RTS, CTS, DCD, DTR, DSR, RI) and trigger input (TRG) can be displayed in waveform.

Control lines are displayed as high level when the line state LEDs light in read.

Signal status of external trigger input terminal is displayed in the “TRG”.

<Line state display>

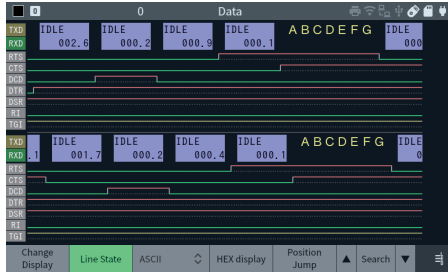

For SPI protocol, “SS” in the line state LED means “RTS”.

Set “Record control” (additional information tab) to record control lines before measuring.



2.2.3 Record Control



11.2 Signal Definition of the Measurement Ports



## Line state LED

Signal status of selected interface are displayed in the LEDs in the right side of LCD.

Press [SHIFT]+[MENU] to display or not to display the name of line state.

Control lines of line state LEDs are displayed in red at high level.

Names of line state LEDs are changed according to the signal definition of selected interface.



11.2 Signal Definition of the Measurement Ports



## End of measurement

Press [STOP] to end the measurement. It is possible to stop measuring by setting of trigger function, capture memory setting (full stop), and auto measurement function.



2.2.3 Record Control



6.1 Trigger Function

■ Scroll

Swipe the data display to scroll measured data.

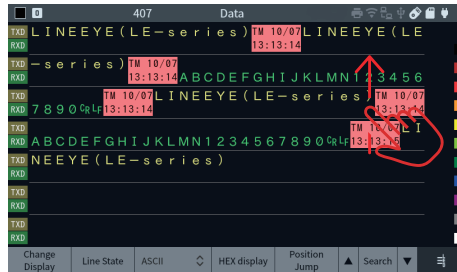
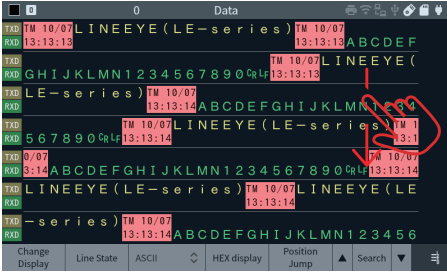

Swipe down the display to see backward (old) data.

Swipe up the display to see forward (new) data.

Also, use keys to scroll data, and [SHIFT]+ [▲] or [SHIFT]+ [▼] to jump to another page.

■ Jump

Tap “Jump” to display the jump setting window.

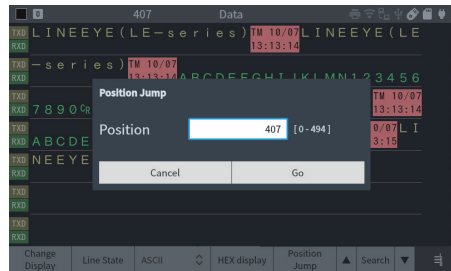
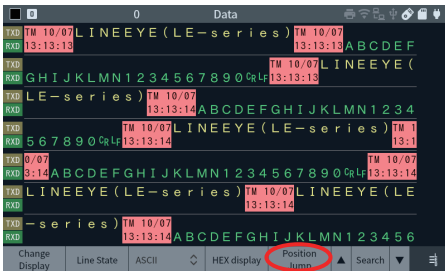

Type the positioning number using [0]-[9] keys and press [ENTER] to see the specified data.

 If inputted position No. is bigger than existing No., the last page will be displayed.

[SHIFT]+[TOP/DEL] Display the oldest data (positioning number 0).

[SHIFT]+[END/X] Display the latest data.

## Mark & Jump

It is able to register (mark) max. 9 positions of data. This function is useful to go back to the registered (marked) positions when you have a huge amount of data.

Register the data position by [SHIFT] + [1]-[9]. Press [1]-[9] to display the registered (marked) position.

Press [Shift] and “mark jump” to display the list of registered position.

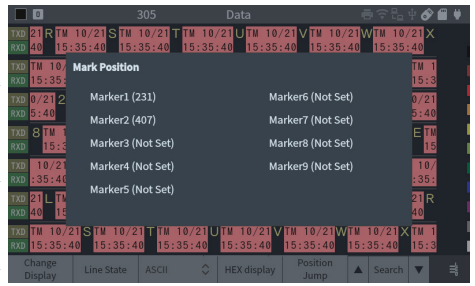

Specification of Frame Translation for SDLC, SDLCE, X.25, X.25E

Item	Meaning
Time stamp	Shows the time when the frame was received.
AD	Displays the contents of the address field in HEX codes.
Type	Displays the frame type in the form of mnemonic.
NS	Displays the frame sequence number with the decimal notation.
PF	Displays the logical value of P/F bit.
NR	Displays the frame sequence number with the decimal notation.
FC	Displays the results of frame check.
Data	Displays the information field data.

 SDLC/X.25 frame translation operates by modulo 8, and SDLCE/X.25E frame translation operates by modulo 128.

Specification of Frame Translation for LAPD

Item	Meaning
Time stamp	Shows the time when the frame was received.
SAP	Displays the value of service access point identifier with the decimal notation.
TEI	Displays the value of the termination point identifier of the terminal with the decimal notation
CR	Displays the value of COMMAND RESPONSE display bit.
Type	Displays the frame type in the form of mnemonic.
NS	Displays the frame sequence number with the decimal notation.
PF	Displays the logical value of P/F bit.
NR	Displays the frame sequence number with the decimal notation.
FC	Displays the results of frame check.
Data	Displays the information field data.

Specification of Packet Translation for X.25

Item	Meaning
Time stamp	Shows when the packet was received.
GN	Indicates the logic channel group number with the decimal notation.
LCN	Indicates the logic channel number with the decimal notation.
P-Type	Indicates the packet type in mnemonic.
PS	Indicates the packet transmission sequence number with the decimal notation.
PR	Indicates the packet transmission sequence number with the decimal notation.
M	Indicates the logical values of more data bit.
Q	Indicates the logical values of qualifier bit.
D	Indicates the logical values of transmission verification bit.
FC	Displays the results of frame check.
Data	Indicate the information field data after the packet in HEX.



□ MODBUS

Frame dump display and translation display (only address/control on top of frame) is possible.

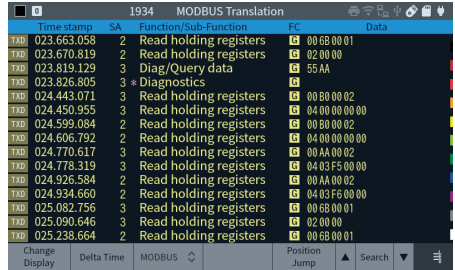
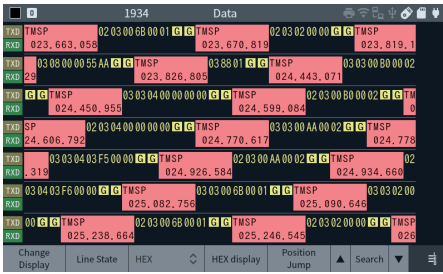

Touch “MODBUS” on the bottom of screen and select “Dump” or “MODBUS”.

It is able to change the specification of Translation display anytime. (during test too)

Item	Meaning
Time stamp	Shows the time when the frame was received.
SA	Display the device address in decimal.
Function/Sub-function	Display the value of function code in mnemonic.
FC	The result of frame check (LRC).
Data	Display the contents of data field in HEX.

10.5 Translation Display Specification

- Detail view

“Detail view” is available after the measurement (not available while measuring). “Detail view” displays data conformed to the Power Meter “KWIM (by Panasonic)”. It translates the frame on top of the screen. “Request/Response” function translates the frame as “Response” if the slave address and function code match with the one on the last frame.

- Slave address:

Slave address is displayed in decimal.

It can be displayed in character by setting “Modbus translation display”.

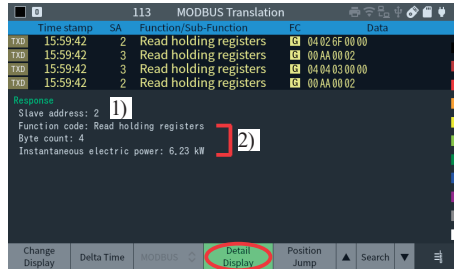

- Translation:

It displays translated data according to the function code.

Press [SHIFT] key and “Translation order Switching” to change the displaying order of “Request/Response” translation.

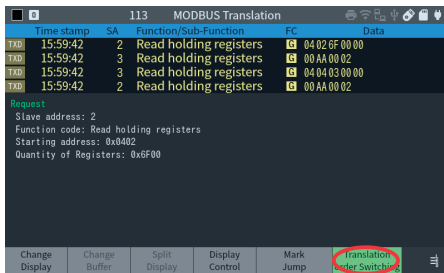

• Modbus Translation display

Press [SHIFT] key and “Display control”-> “Modbus detail view”-> “Setting”.

Define the slave address up to 16 kinds.

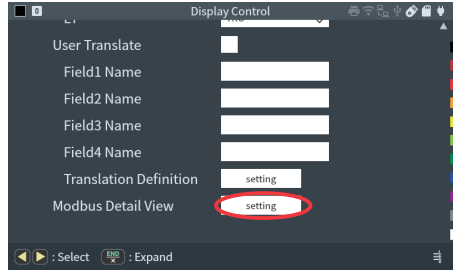

Input the slave address and character to be displayed. To valid the table, mark on the check box. If selecting more than two check boxes for same address, the younger number will be applied.

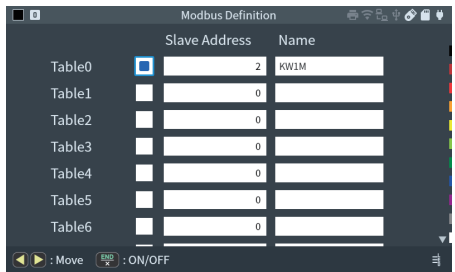

“2” which is set in “Slave address” is displayed as “KW1M”.

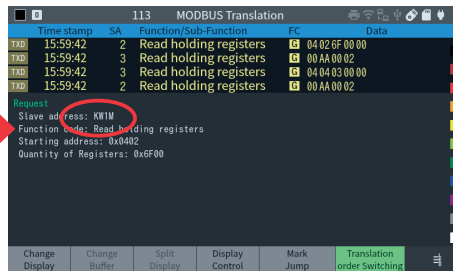

□ I2C

It translates data using some arrows to explain the data flow.

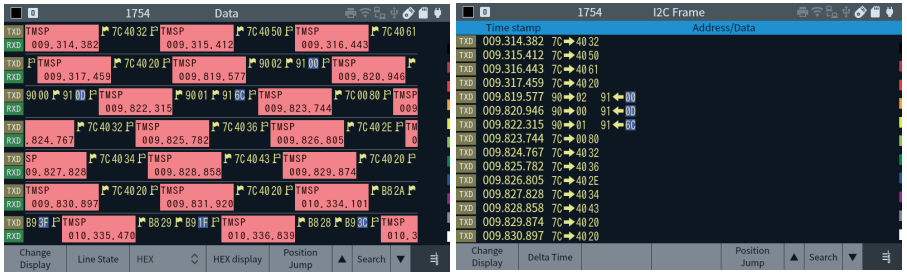

Item	Meaning
Time stamp	Shows the time when the frame was received.
⇒	Transmission data of master.
⇐	Reception data of master.
🚫 etc.	Non-acknowledge data.
Address/Data	Display the slave address and data in HEX.

□ I3C

The frame display content is the same as for I2C.

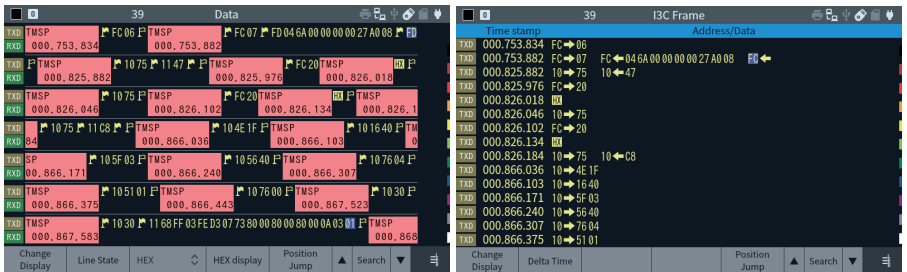

Inverted data indicates a non-acknowledgement of the address field, or T-bit = 0 (end of data) during Read.



Display item	Display contents												
TXD/RXD	Indicates the port in which frame is received.												
Time stamp	Indicates the time when frame is received.												
DA	Displays the Destination address in decimal.												
DSAP	Displays the Destination service access point in decimal.												
SA	Displays the source address in decimal.												
SSAP	Displays the Source service access point in decimal.												
Frm/Function	Translates and display the frame type or function code. Meaning of special indications												
	<table border="1"> <thead> <tr> <th>Display</th> <th>Contents</th> </tr> </thead> <tbody> <tr> <td>[TOKEN]</td> <td>SD4(0xDC) frame</td> </tr> <tr> <td>[SC]</td> <td>Single Character (0xE5)</td> </tr> <tr> <td>[(XX)]</td> <td>First byte of unknown data string (hexadecimal)</td> </tr> <tr> <td>[ILL]</td> <td>When SD2 length (LE, LEr) is incorrect</td> </tr> <tr> <td>(XX)</td> <td>Non-translatable function code (Hexadecimal) (FCB(b5) and FCV(b4) are masked and displayed)</td> </tr> </tbody> </table>	Display	Contents	[TOKEN]	SD4(0xDC) frame	[SC]	Single Character (0xE5)	[(XX)]	First byte of unknown data string (hexadecimal)	[ILL]	When SD2 length (LE, LEr) is incorrect	(XX)	Non-translatable function code (Hexadecimal) (FCB(b5) and FCV(b4) are masked and displayed)
	Display	Contents											
	[TOKEN]	SD4(0xDC) frame											
	[SC]	Single Character (0xE5)											
	[(XX)]	First byte of unknown data string (hexadecimal)											
	[ILL]	When SD2 length (LE, LEr) is incorrect											
(XX)	Non-translatable function code (Hexadecimal) (FCB(b5) and FCV(b4) are masked and displayed)												
XX is a two-digit hexadecimal number.													
FC	Displays the check result of FCS (Frame Check Sequence).												
	<table border="1"> <thead> <tr> <th>Display</th> <th>Contents</th> </tr> </thead> <tbody> <tr> <td>G</td> <td>Correct value</td> </tr> <tr> <td>E</td> <td>Incorrect value</td> </tr> <tr> <td>B</td> <td>Break detection (not FCS result)</td> </tr> </tbody> </table>	Display	Contents	G	Correct value	E	Incorrect value	B	Break detection (not FCS result)				
	Display	Contents											
	G	Correct value											
E	Incorrect value												
B	Break detection (not FCS result)												
Data	The protocol data unit (PDU) field data (not including the address extension) is displayed in hexadecimal (up to 5 bytes).*1												

\*1 : When the continuous data string cannot be recognized as a PROFIBUS DP standard frame, the 2nd and subsequent bytes are displayed. Also, the dump display shows up to 26 bytes of data from the beginning of the frame in hexadecimal.

 If the data string cannot be recognized as PROFIBUS DP standard, it displays the second byte of data and its following data.

## 10.5 Translation Display Specification



## Bit Shift Function

This function shifts the separation of characters of received data bit by bit, to find errors such as deviations from the character synchronization of serial data.

When the characters are displayed on the data display, press [SHIFT]+[ ◀ ]. Then, the character separation is shifted one bit from the lower bit to the upper bit.

Press [SHIFT]+[ ▶ ], and the character separation is shifted one bit from the upper bit to the lower bit. A mark bit ('1') is added to the lowest (or highest) bit position where continuity of the data is broken, such as the head character of a frame.

- ☰ The bit shift is applied only to the screen and not applied to the data in the memory.
- ☰ The scroll paging operation eliminates the bit shift operation.
- ☰ Successive bit shifts can be made up until the number of bits constituted a character.

e.g.) CODE: EBCDIC, bit length 8

LSB side (first arrived bit) ← Order of bits arrival → (last arrived bit) MSB side

### ■ Before shift

Received data

10011000	10011001	00000110	10000111	10000110
‘E <sub>M</sub> ’ 19h	‘r’ 99h	‘-’ 60h	‘\E1h	‘/’ 61h

### ■ After 1 bit shift

Received data

01001100	01001100	10000011	01000011	11000011
‘I <sub>R</sub> ’ 33h	‘S <sub>y</sub> ’ 32h	‘A’ C1h	‘B’ C2h	‘C’ C3h

Mark bit added

## 3.2 Retrieval Function

The retrieval function finds specific data among the vast amount of data recorded in the capture memory. It also counts the number which satisfies a particular condition.

### Retrieval Setting

Touch “Search” on the bottom of screen and select the factor at “Search factor”.

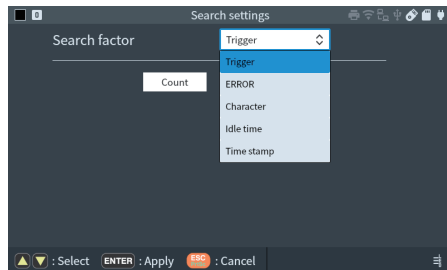

- Trigger

Data which satisfies the trigger condition (Factor) is retrieved. Trigger is not retrieved in the case the trigger condition is “Timer/Counter”.

- Error

Retrieve errors which are selected.

- Character

Retrieve data string up to 8 character.

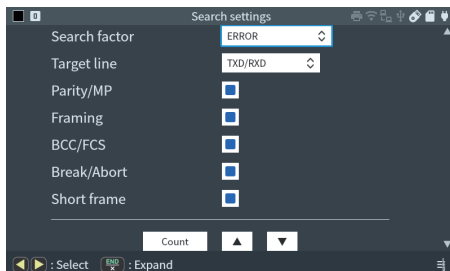

- Target line

Select the target line from TXD or RXD.

- Character

Sets the character string to be retrieved in HEX.

Input data using [0] ~ [F]keys, and [END/X](don't care).

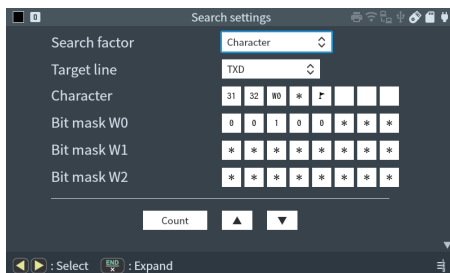

Press [SHIFT] + [0] for bit mask W0

Press [SHIFT] + [1] for bit mask W1

Press [SHIFT] + [2] for bit mask W2

Press [SHIFT] + [F] to include the HDLC flag.

In the right figure, “W0” should be matched with 30h ~37h, and 2 bytes of frame error code is “x”, and there is an end frag.

■ Idle Time

It cannot be used for high-speed mode.  
Retrieve idle time which exceeds the set value.

The unit of idle time for retrieval should be the same unit of idle time when it is measured.

To retrieve the data with timeout, input the timeout time here.

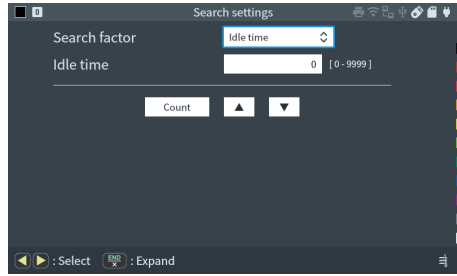

■ Time Stamp

It cannot be used for high-speed mode.  
Retrieve specified time stamps. The setting unit of time stamp for retrieval should be the same unit of time stamp when it is measured.

Specifying data with time stamp enables to find data when communication trouble occurs.

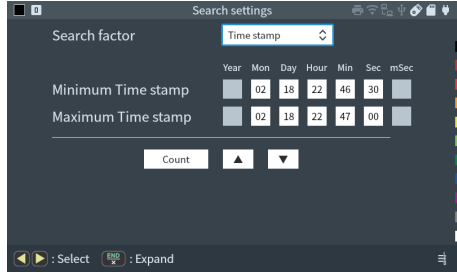

☰ In the right figure, it retrieves the data between 22:46:30 on Feb. 18th and 22:47:00 on Feb. 18th.



## Start Retrieval

Tap “▲” “▼” to display the matched data on the top of the screen.

“▲” : Retrieve previous (older) data, starting from the top of data displayed on the screen.

“▼” : Retrieve backward (newer) data, starting from the top of data displayed on the screen.

Tap “Count” to display the number of matched data in the pop-up window.

If there is no matched data, “Not Found” is displayed.

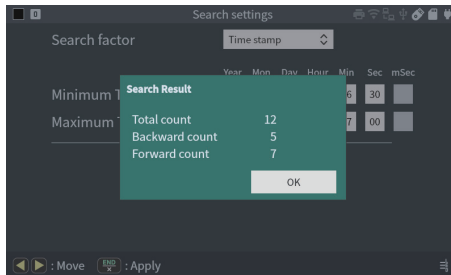

### 3.3 Delay Time and Signal Voltage (DELAY)

Delay time function measures the delay time between state changes of the interface signal, and measures the voltage (Max./Min./Current) of the signals on RS-232C/422/485.

It cannot be used for high-speed mode.

#### Setting

Press “Mode” -> “Delay”-> “Delay Opt.” from top menu to set the start/stop conditions of delay time measurement.

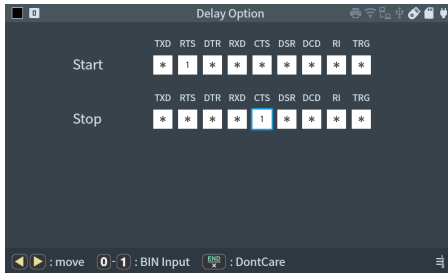



#### ■ Start

The following nine signal lines are needed to be set : TXD, RTS, DTR, RXD, CTS, DSR, DCD, RI, and TRG (external trigger signal). Specify the state of each signal by [1](on state), [0] (off state), and [END/X](don't care).

#### ■ Stop

Specify the state of each signal as same as start condition.

 “On state” indicates the active state of signal. For RS-232C, it is +3 or higher (space state) of voltage level. For TTL, it is a low level.

 For TTL, only TXD, RXD, RTS and CTS are the target signal lines. For RS-422/485, only TXD and RXD are the target signal lines.

Signal voltage of TTL signal cannot be measured.

If selecting “Interface” as “TTL”, signals on RS-232C port is measured.



## Start and End of Measurement

Press [RUN] to start measuring of delay time and signal voltage.

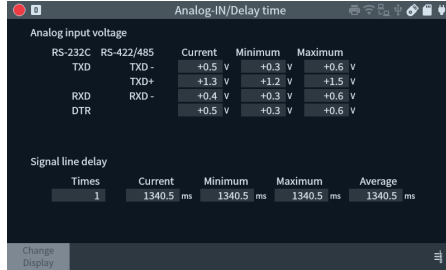

Press [Stop] to stop measuring.

### ■ Display of signal voltage

Measure voltage of target interface and display signal voltage (MAX. MIN. Now).

Target signals

For RS-232C port	TXD,RXD,DTR
For RS-422/485,RS-530 port	TXD-,TXD+,RXD-

Range of signal input : -12V ~ 12V

Resolution of voltage measurement is 0.1V.

If the input voltage is above 15V, the protection diode of analyzer clamps it.

### ■ Display of delay time

Delay time is the time between start and stop condition of the signals, and displayed by Max. Min, reset (Now) and average. The start/stop conditions are established when the nonconformity of the two conditions becomes the conformity of those. Thus, start/stop conditions will not be established when they are conformed from the beginning.

The change of signals within 0.1ms cannot be detected. (resolution is 0.1ms).

If the reset value (Now) exceeds the range of signal input, “Overflow” will be displayed. And, the value of “Max” and “Min” may not be accurate, even though it keeps measuring the next target.

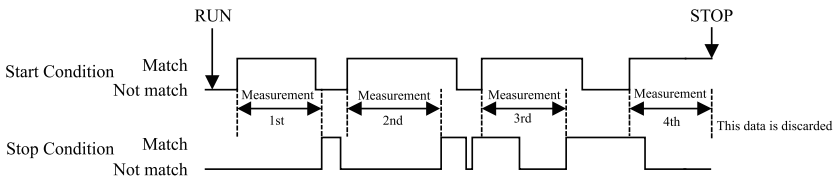

## 3.4 Statistic Analysis Function (Trend)

---

The statistical analysis function is capable of counting the occurrence of the events such as the number of characters and frames in a specific period, and displaying the results on graph to check how the occurrence of them changes over time. This function is useful to check the frequency of the use of a channel.

It cannot be used for high-speed mode.



### Setting

---

Press “Mode” -> “Trend”-> “Trend Opt.” from top menu to set the event and resolution of Statistic (Trend) function.

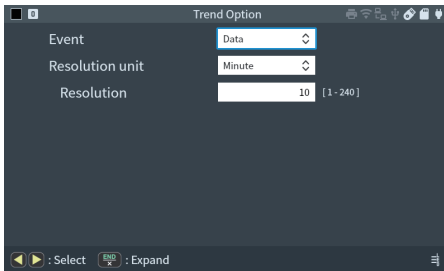

#### ■ Event

Select the statistical target.

- Data All data on the TXD and RXD is the target. It is useful to check the traffic on the line.
- Frame All frames on the TXD and RXD is the target.
- Trigger The number of the events which satisfies the trigger factor 1 and 2 is the target. It is useful to check the frequency (trend) of specific error or data.

 In the Trend function, only trigger factor 1 and 2 are valid, and trigger action does not work. Confirm the trigger condition 1 and 2 to work with trend function.

 6.1 Trigger Function

#### ■ Resolution unit

Select the resolution from second or minute.

#### ■ Resolution

Set a resolution, unit time for statistical processing, on a horizontal scale of a graph. (1 ~ 240 sec/min) Statistically, processed data up to Max. 2000 times can be recorded.

 If setting 10 min. for the resolution, it can measure 20,000 min. (333 hours 20 min.)



## Start and End of Measurement

Press [Run] to start measurement.

As a number of times of statistical processing passes, the results of calculated value are updated on a graph. A vertical scale is automatically adjusted according to the results of data.

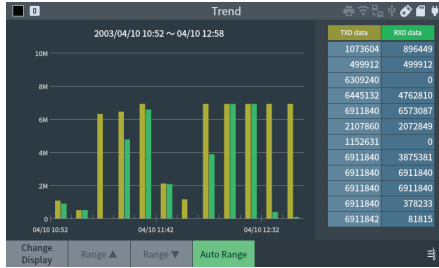

Press [STOP] to stop measuring. After 2000 times of statistics, it will finish measuring automatically.

### ■ Scroll

It is able to swipe the bar graph to scroll the screen after the measurement.

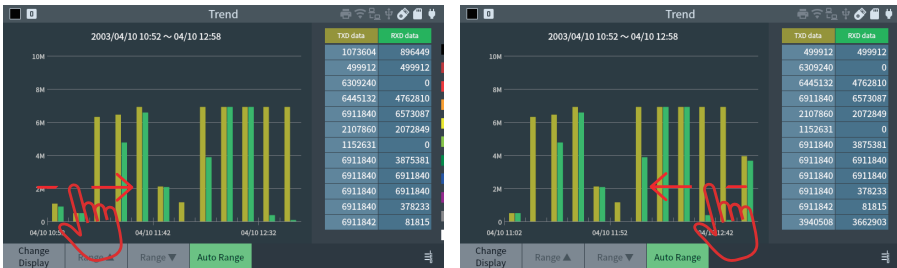

Also, it is able to scroll data by [ ◀ ], [ ▶ ] and go to next (previous) page by [SHIFT]+ [ ◀ ], [SHIFT]+ [ ▶ ]

Display the beginning/end of data by pressing [TOP/DEL]/ [END/X].

### ■ Change vertical scale

To change the range of vertical scale manually, touch “Auto range” to release this function. And then touch “ ▼ ”, “ ▲ ” to change the range.

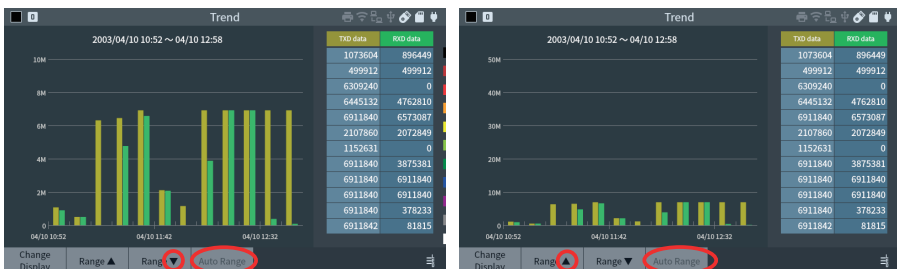

# Chapter 4 Simulation Function

The simulation function is the tool that makes the analyzer operating as a communication partner with a test device, and that executes a test for transmission and reception following protocols. Even if communicated devices are not prepared at the first step in developing, the testing like real operation will be able to be executed. After checking communication procedure in our original “MANUAL mode,” complicated communication procedure with conditional branches will be able to be tested by command-selected easy programming. A margin can be evaluated at staggered communication speed on purpose because appointed communication speed can be set. Moreover, error processing response can be checked with tested data which includes parity error data.

## ■ MANUAL Mode

Registered data of the transmission table corresponding to operation keys [0] to [F] is transmitted one touch every time each key is pressed. Communication procedure can be easily tested with the trigger function checking response from the developed devices through the monitor function. In addition, by pressing [SHIFT] and one key from [0] to [D] fixed data corresponding to each key can be transmitted. Also, pressing [SHIFT] and [E],[F] makes the signal line of RTS/CTS or DTR/DCD set ON/OFF.

## ■ BUFFER Mode\*

Recorded transmission or reception data is selected in a memory through the monitor function. And then, that data is transmitted as simulation data. It is useful to perform a reproducing test for data with the same communication state monitored in the field.

## ■ FLOW Mode\*

As a transmitter or a receiver, X-ON/OFF flow control and control line handshake can be simulated. In the transmission mode, the number of transmission data for sixteen times can be displayed from a start to an interrupt request. On the other hand, in the reception mode, two things can be appointed. One is the number of reception data of until an interrupt request is submitted for transmitting. The other is time of until a start request is submitted for transmitting.

## ■ ECHO Mode\*

Received data is turned back from the analyzer. It is used for testing a communication terminal (display terminal etc.) and used as a loop-back point for BERT.

## ■ POLLING Mode\*

The slave side or the master side based on polling communication procedure of multidrop (1:N connection) is simulated. In the slave mode, the number of frame reception times and an error is checked at the self-address.

And then, appointed data is replied. In the master mode, polling messages are transmitted to 32 kinds of the slave addresses. And then, response data is checked in each slave address.

## ■ PROGRAM Mode\*

By programming for a dedicated command, communications protocol involved in the conditional judgment is flexibly simulated. There is the selectable menu for programming so it is easy to master this mode.

## ■ PULSGEN mode

The timing waveform data of the communication line measured by the timing waveform measurement function can be output as is. As the waveform data can also be edited, various tests such as data output different from the standard timing are available.

\* Cannot be used in high-speed mode.



## 4.1 Register Transmission Data

Register transmission data in the data tables before starting simulation. For Polling/Program mode, this registered data is used as comparison data with received data.

### Register data

Data code and BCC/FCS used in the registration table are set on the configuration setting. Press [MENU] and then touch “Configuration” and confirm the communication conditions.

#### 2.4 Communication Condition Settings

Select the operation mode that uses the send data table from “Mode” on the top menu screen, and tap “Send Table” to display the send data table selection screen.

There are 160 transmission data tables, from table 00 (number 0 of group 0) to table 9F (number F of group 9), and a total of 16384 characters of data can be registered.

At first, the table of group 0 is displayed on the transmission data table selection screen.

You can switch to other groups by tapping “Group Increment” “Group Decrement” at the bottom of the screen, or by pressing [◀] or [▶].

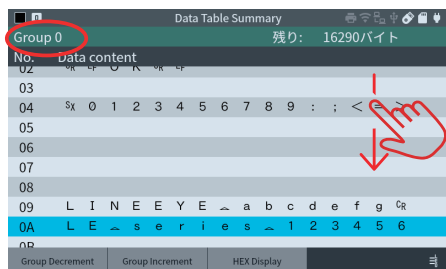
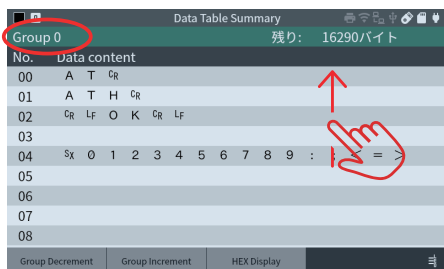
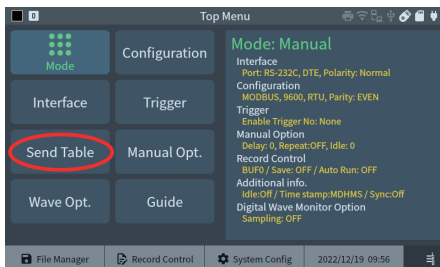

 Only the first 16 characters are displayed on the screen.

Swipe to scroll the table screen. Tap the table you want to register, or select it with [▼], [▲] and press [ENTER] to display the table data input screen.

 It is able to select the table No. by [0]~[F] key.

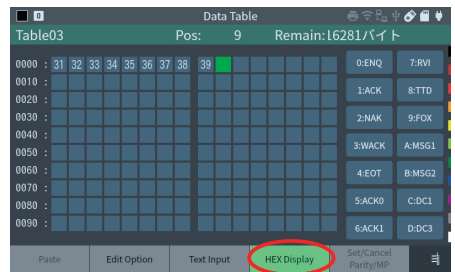
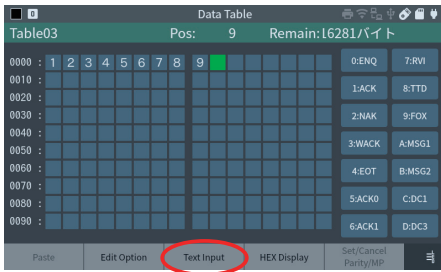

On top of the screen, table number, position of cursor, and rest of buffer (remained bytes) on the transmission data table are displayed. A cursor position on the screen where under-line is blinking is the place to input data. Move the cursor position by [◀],[▶],[▼],[▲] or touch the place. Input registration data by [0]~[F] in HEX, or touch “Text input” on the bottom of screen. Inputted data is displayed with the selected data code. Touch “HEX display” to display data in HEX.

- 📄 To see the first or last data, press [SHIFT]+[TOP/DEL] or [SHIFT]+[END/X].
- 📄 To modify entered data, move the cursor to the position and modify data.
- 📄 To delete entered data, move the cursor to the position and press [TOP/DEL].

#### ■ Text input

Touch “Text input” to enter data by a key board. Entered data is appeared on the top of screen. Change to capital letter by “↑A”, and change to symbols by “#!?”. Press [ENTER] or touch “OK” at the end. Entered data will be inserted in the previous transmission data tables.

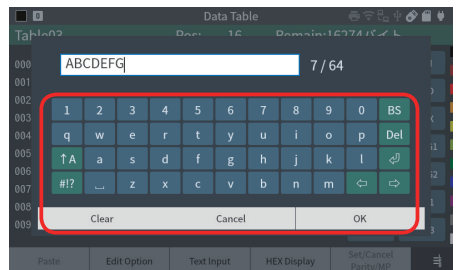

- 📄 It is able to use [0]~[F] keys for inputting character 0~F.
- 📄 Input text remains in the text box until turning off the power. Touch “Clear” to delete data.

■ Parity Error and MP Bit Setting

By tapping “Set/Cancel Parity/MP”, the data at the cursor position will be added with the attribute of parity error or multiprocessor bit 1 and it will turn red. Perform the same operation again to return to the original.

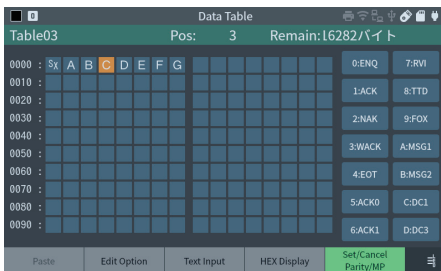

📖 Set the type of “parity” in the “Configuration” setting.

■ BCC/FCS Auto Calculation

The correct BCC and FCS are automatically calculated and added to the data by pressing [SHIFT]+[ENTER] or by selecting “add BCC/FCS” in “Edit Option”.

📖 10.1 Calculation of the Block Check

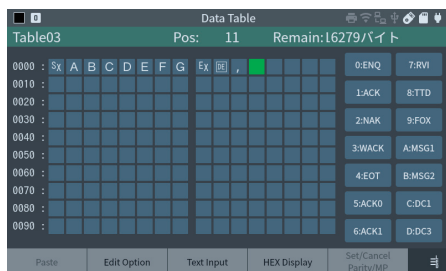

The correct BCC and FCS are automatically calculated and added to the data by pressing [SHIFT]+[ENTER] or by selecting “add BCC/FCS” in “Edit Option”.

BCC: CRC-16, Begin code: “01h” or “02h”, End code: “03h” or “17h”

📖 If you change the setting of 'BCC' in 'Configuration' or change the data to be calculated, please recalculate with the same operation again.

■ Data code and data bit

Inputted data is displayed with the selected data code. (“Configuration” -> “Data code”)And, the data code cannot be changed by “SHIFT IN” and “SHIFT OUT” operation. Also, the data bit has to be same as configuration. (“Configuration” -> “Data bit”) For example, if data bit is set as “7”, “13h” will be sent instead of wrong inputting “93h”.

■ Copy, cut and paste

If you long-tap or press [ENTER] anywhere in the data to be sent, it enters into the range selection mode with the data at that location selected.

The selection range can be changed by dragging the selection edge or by [◀], [▶] operations. The length of the selected range is displayed in “Len” on the screen.

Save the selected range to the clipboard by tapping “Cut” or “Copy”.

Tap [ESC] or tap “Cancel” to cancel the range selection mode.

Also, if you tap “Cut” or press [TOP/DEL], the data in the selected range will be cut and copied to the clipboard.

Tap “Paste” to insert the contents of the clipboard at the cursor position. Move the cursor to the position where you want to insert the data copied to the clipboard and tap “Paste” or press [END/X] to paste the clipboard data at the cursor position.

 Copied or cut data on the clip board will be eased after turning off the power.

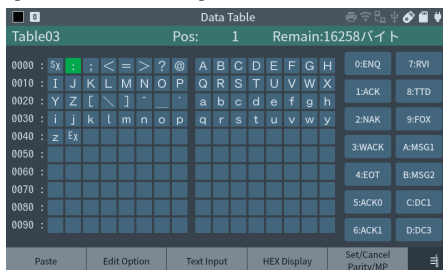
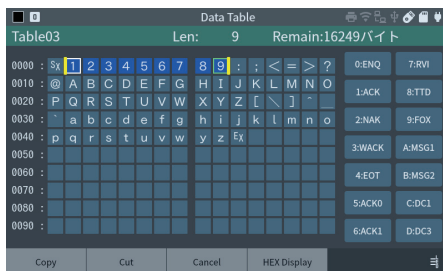
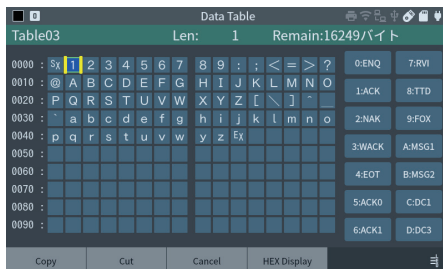

■ Delete table

All data registered in the current table input screen can be cleared. Select “Clear table” from “Edit Option”.

■ Fill in data

Select “Edit Option” from “Data fill” and enter start/end data and size.

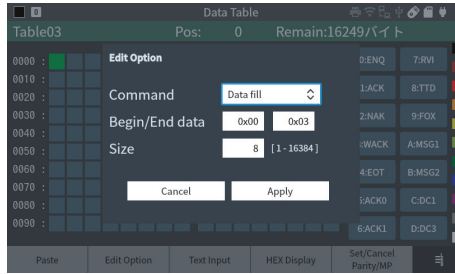

Begin data< End data : A character from “Begin data” toward “End data” will be inputted increasing one by one till the number of size set in “Fill size” is filled.

Begin data> End data : A character from “Begin data” toward “End data” will be inputted decreasing one by one till the number of size set in “Fill size” is filled.

Begin data= End data : The data is entered into the table for the specified size.

On the right figure, “01h, 02h, 03h, 01h, 02h, 03h, 01h, 02h” will be inserted in the table.

📄 Input “Begin data” and “End data” by [0] ~ [F] in HEX.

📄 If there is not enough remains, it will fill the data partway.

■ Copy table

You can copy data from other tables.

Select “Copy table” from “Edit Option” and enter the table number you want to copy.

■ Copy buffer

It is able to copy monitored data into the table. At first, display monitored data on the screen and adjust the head of data to be copied on the upper left of screen.

Select “Copy buffer” from “Edit Option” and enter the target line (TXD/RXD) and size you want to copy.

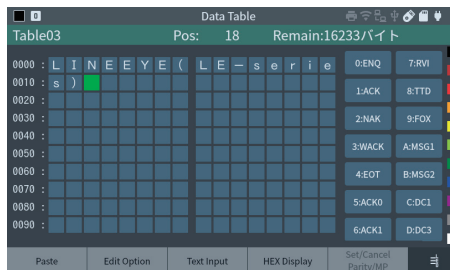
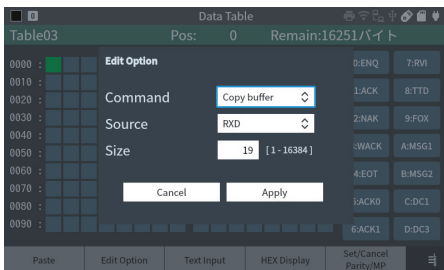

📄 Idle time and time stamp are not copied.



## Fixed Transmission Data (Pre-set data)

Special characters like ENQ, ACK, etc. can be inputted. Preset data can also be input by tapping the display shown when [SHIFT] is pressed, or by operating the keys described in the table below.

[SHIFT]+[0]	ENQ	[SHIFT]+[7]	RVI
[SHIFT]+[1]	ACK	[SHIFT]+[8]	TTD
[SHIFT]+[2]	NAK	[SHIFT]+[9]	' FOX ' Message <sup>(*)1</sup>
[SHIFT]+[3]	WACK	[SHIFT]+[A]	MSG1 ' Message <sup>(*)2</sup>
[SHIFT]+[4]	EOT	[SHIFT]+[B]	MSG2 ' Message <sup>(*)3</sup>
[SHIFT]+[5]	ACK0	[SHIFT]+[C]	DC1(11h)
[SHIFT]+[6]	ACK1	[SHIFT]+[D]	DC3(13h)

\*1 : THE QUICK BROWN FOX JUMPS OVER A LAZY DOG 0123456789.

\*2 : S<sub>x</sub>0123456789ABCDEFGHIJKLMN<sub>x</sub>OPQRSTUVWXYZ<sub>x</sub> BCC

\*3 : 0123456789ABCDEFGHIJKLMN<sub>R</sub>OPQRSTUVWXYZ C<sub>R</sub>L<sub>F</sub>

- ◆ HEX value of pre-set characters ([SHIFT] + [0] to [8]) are changed according to the selected data code in "Configuration" setting. Refer to following table.
- ◆ Characters, which are not defined in the code table, are ignored.

	ASCII/JIS/HEX	EBCDIC/EBCDIK	Transcode	Others
ENQ	05h	2Dh	2Dh	-
ACK	06h	2Eh	3Ch	-
NAK	15	3Dh	3Dh	-
WACK	10h · 3Bh	10h · 6Bh	1Fh · 26h	-
EOT	04h	37h	1Eh	-
ACK0	10h · 30h	10h · 70h	1Fh · 20h	-
ACK1	10h · 31h	10h · 61h	1Fh · 23h	-
RVI	10h · 3Ch	10h · 7Ch	1Fh · 32h	-
TTD	02h · 05h	02h · 2Dh	0Ah · 2Dh	-

## Register I2C Simulation Data

To receive data, it is necessary to register the same amount of dummy data.

### □ I2C Master Mode

At first, set the slave address (including a read/write bit) and then set transmission/reception data. Start/stop sequence are added automatically at the beginning and end of data.

To receive data, it is necessary to set the same amount of dummy data.

 To insert a restart sequence, tap “Set/cancel Parity/MP” at the data you want to insert it.

e.g.1 : Transmit data (41h, 42h, 43h) to the slave address “1010000b” (7bit).

Register in the data table: A0h 41h 42h 43h

A0h (10100000b) : Write request to the slave address

41h 42h 43h : 3byte of transmission data

e.g.2 : Receive 3 byte of data from the slave address “1010000b” (7bit).

Register in the data table: A1h 00h 00h 00h

A1h (10100001b) : Read request to the slave address (bit 0=1)

00h 00h 00h : 3byte of dummy data

e.g.3 : Transmit data (41h, 42h, 43h) to the slave address “1010000b” (7bit), and then receive 3 byte of data from the slave address.

Register in the data table: A0h 41h 42h

43h A1h 00h 00h 00h

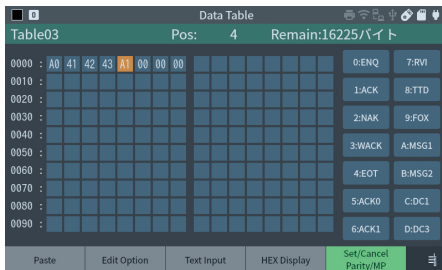

A0 (10100000b) : Write request to the slave address

41h 42h 43h : 3byte of transmission data

A1 (10100001b) : Re-start + Read request to the slave address (bit 0=1)

00h 00h 00h : 3byte of dummy data

 Move the cursor to 'A1' and tap “Set/cancel Parity/MP”.

Execution screen of example 3

A screen when 31h, 32h, 33h sent by the I2C slave device under test are received after sending 41h, 42h, 43h.



□ I2C Slave Mode

Set the transmission data to send after receiving a request from the master. To receive data, it is necessary to register the same amount of dummy data. Registered data (more than 1byte) is used repeatedly when it receives data from the master, and when it transmits data after receiving a request from the master.

e.g.1 : Transmit 31h, 32h, 33h, 31h, 32h, 33h after receiving 6 byte of send request from master.

Set the address for I2C slave mode (7-bit address: 1010000b) in “Configuration” on the top menu.

Simulation mode : SLAVE  
Address bit : 7 BIT  
Slave address : 0A0

Register in the data table: 31h, 32h, 33h, 31h, 32h, 33h

☰ Registering only “31h, 32h, 33h” in the transmission data table will be the same result.

e.g.2 : Receive 16 byte of data from master.

Register in the data table: 00h

☰ If there is nothing in the data transmission table, data cannot be received.

☰ For I2C, the first to 520th bytes of each transmission data table are valid. Even if you set more data, the usage will be ignored.

☰ To receive data, press [RUN] to start measuring and then press a corresponded key with data transmission data table No. before starting the communication from master. (Manual mode)

## 4.2 RS-422/485 Driver Control

Select the method of controlling RS-422/485 transmission driver IC for simulation on RS-422/485 port.

Select “Interface” from the top menu screen, select “RS-422/485/530” from “Measurement port”, and set the method of “Driver control”.

### 2.3 Measurement Port

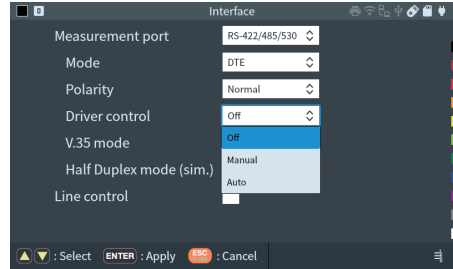

#### ■ Driver Control

**OFF** : Select to test full-duplex connections RS-422, X.20/21, RS-449, V.35. After the test starts, the driver IC is always ready for transmission (enable).

**Manual** : When DTR (for DTE mode) or DCD (for DCE mode) is ON, the driver will be in an enable state. And when DTR or DCD is OFF, the driver will be in disable (high impedance) state. It is used to control the driver IC manually for Manual or Program mode.

 When “Line control” is checked, the driver IC is controlled according to the state in which DTR and DCD are automatically controlled.

 When “Line control” is set OFF, the initial state at the start of simulation is below:

Simulation mode	Initial State of TXD Driver IC
Manual mode	High impedance state
Flow mode	Enable
Echo mode	Enable
Polling mode	Enable
Buffer mode	Enable
Program mode	High impedance state
PULSGEN mode	Transmission available state (always)

**Auto** : Select “Auto” for testing RS-485 in half duplex. The driver automatically be in an enable state during the transmission of test data, and the driver will automatically be in disable after about 1 to 3 bits is delayed (400u seconds at least) after data transmission.

# 4.3 Auto Line Control

ON/OFF of control lines and timing of data transmission can be controlled automatically according to the setting of interface mode (DTE/DCE) for simulation.

“ON” means active, and “OFF” means non-active.

Select “Interface” from the top menu screen, select “RS-232C” or “RS-422/485/530” as the “Measurement port”, and enable the “Line control” checkbox.

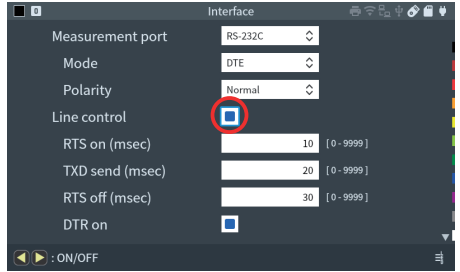

## ○ DTE mode

Set the timing of following item in the range between 0 and 9999 ms.

- RTS on

Time between the start of data transmission and RTS becomes “ON.”

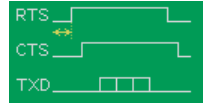

- TXD send

Time between CTS becomes “ON” and the start of data transmission.

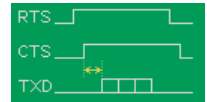

- RTS off

Time between the end of data transmission and RTS becomes “OFF”.

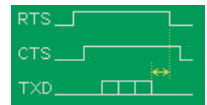

- DTR on

DTR is always “ON” during test.

< Example of above program >

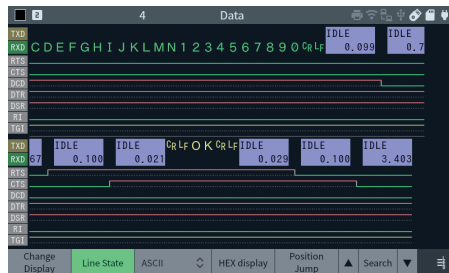

○ DCE mode

Set the timing of following item in the range between 0 and 9999 ms.

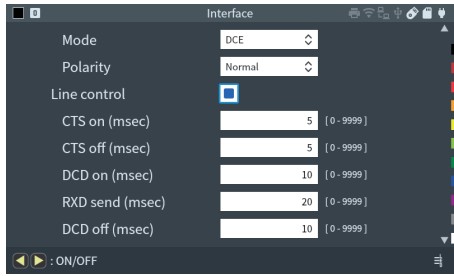

■ CTS on

Time between RTS becomes “ON” and CTS becomes “ON”.



■ CTS off

Time between RTS becomes “OFF” and CTS becomes “OFF”.



■ DCD on

Time between the start of data transmission and DCD becomes “ON”.

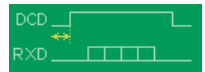

■ RXD send

Time between DCD becomes “ON” and the start of data transmission.



■ DCD off

Time between end of data transmission and DCD becomes “OFF”.

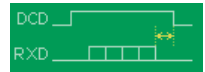

Example data of above setting.

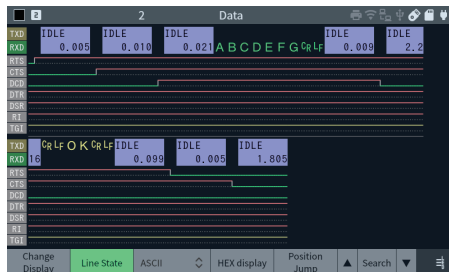

## 4.4 Manual mode

Data in the data table corresponding to each key will be transmitted by pressing a key.

### Setting

Before starting the Manual simulation, set protocol and communication conditions in the “Configuration”, and register transmission data in the data table.

 2.4 Communication Condition Settings

 4.1 Register Transmission Data

Select “Manual” from “Mode” on the top menu screen and tap “Manual Opt.” to display the detailed settings screen for this function.

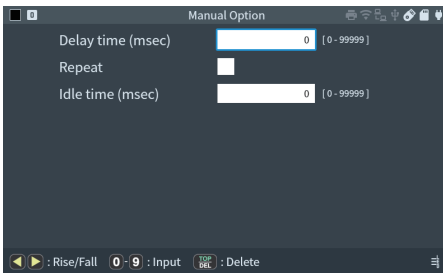

Set the following items below.

Items	Description	Range of Selection
Delay time	Space between characters	0 to 99999 1msec. unit
Repeat	Repetitive transmission of frame	Valid when checked
Idle time	Interval of repeat transmission	0 to 99999 1msec. unit

 The delay time cannot be set in the high-speed mode. Also, it is valid only when the protocol is ASYNC, ASYNC(PPP). Be sure to set 0 for other protocols.

 Even though delay time is set “0”, the analyzer needs some time to process.

Press [RUN] and it will be in a wait state till a key corresponding to the transmission data table is entered.

- When the analyzer is DTE mode

After starting the measurement, RTS and DTR become active. If using the Auto signal control, RTS and DTR change their status according to the setting.

 4.3 Auto Line Control

Entering a data table number (0-F) makes registered data corresponding to the data table transmitted. The data group of data table can be changed by [SHIFT]+ [◀] or [SHIFT]+ [▶] Press [SHIFT]+ [0]~[D] to send a fixed data table. Press [SHIFT]+ [E]/[F] to change control lines (RTS/DTR) ON/OFF.

The respond data will be displayed on the RXD line. It is able make a protocol flow, checking the transmission and reception data.

- When the analyzer is DCE mode

After starting the measurement, CTS, DSR and DCD become active. If using the Auto signal control, DCD and CTS change their status according to the setting. Transmission data is displayed in the RXD line and respond data will be displayed on the TXD line. Press [SHIFT]+ [E]/[F] to change control lines (CTS/DCD) ON/OFF.

In the right figure, it transmits “ENQ” by pressing [SHIFT]+[0]. When receiving “ACK”, it transmits data table 3 (SxABCDEFGF Ex BCC) by pressing [3].  
When receiving “ACK”, it transmits “EOT” by pressing [SHIFT]+[4].

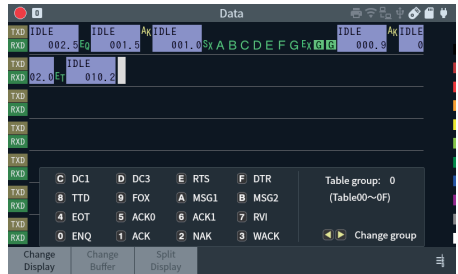

- Break (ASYNC mode only)

Press [END/X] to send a break (active status “0”) for a period of 12 bit. “” will be displayed on the screen.

- Continuous operation

If a new data send table is transmitted while it has been transmitting previous transmission data table, it will finish the previous one first, then send the next table.

It is able to change the control lines by [SHIFT]+ [E]/[F] during the transmission of data tables.

■ Repeat transmission

When ON is set to “REPEAT”, data corresponding tables will be transmitted continuously spacing idle time. To stop this operation, press [TOP/DEL] or select a data table with no data.

Press [STOP] to finish testing.

■ Data that does not require registration

The parity bit, SYNC and BSC protocol SYNC codes and synchronization release codes, and HDLC and SDLC protocol start and end flags are automatically added and sent, so there is no need to register them in the send data table.

## 4.5 Buffer Mode

---

Buffer simulation is the mode to send data of the TXD or RXD side recorded in the capture buffer. Therefore, it can reproduce the communication of data monitored.

This is not available for the high-speed mode.



### Preparation

---

Select the recording area from “BUF1” or “BUF2” which is the half of capture memory.

Monitor communication data and perform a reproducing test in the Buffer mode.

Monitor data and save data in the “BUF1” (or “BUF2”).

To prevent data from overwriting, mark on the box of “Protection”.

Change the recording area to another half of buffer, “BUF2” (or “BUF1”).

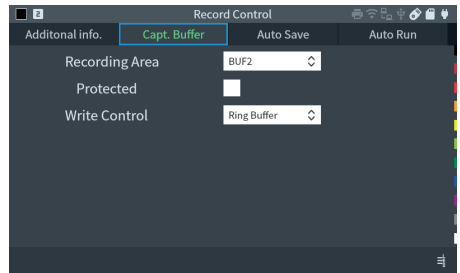

2.4 Communication Condition Settings



2.2.3 Record Control



Buffer simulation is not going to start if it selects “BUF0”.

Select “Buffer” from “Mode” on the top menu screen and tap “Buffer Opt.” to display the detailed settings screen for this function.

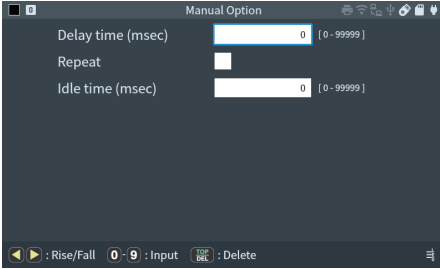

Set the flowing items below.

Items	Description	Range of Selection
Send data	BUF1-TXD:Data side of TXD	BUF1 TXD
	BUF1-RXD:Data side of RXD	BUF1 RXD
	BUF2-TXD:Data side of TXD	BUF2 TXD
	BUF2-RXD:Data side of RXD	BUF2 RXD
Delay time	Space time between characters	0 ~ 99999ms 1msec. unit
Repeat	Appointing repetitive transmission	Valid when checked
Idle time	Space time between frames	0 ~ 99999ms 1msec. unit

To send data in the TXD, select DTE mode. To send data in the RXD, select DCE mode. Set the conditions of analyzer as same as the condition of monitored data.

 2.3 Measurement Port

 2.4 Communication Condition Settings

 If the condition of analyzer is not same as the condition of monitored data, the result of this testing may not be accurate.



## Operation

Press [RUN] and data in the selected buffer on the TXD or RXD will be transmitted from the oldest data. Data is transmitted by one frame unit continuously spacing “Idle time”.

### ◆ Limitation of operation

- If one frame contains more than 4K characters, analyzer divides its data and sends the first 4K characters.
- Framing error of ASYNC is transmitted as normal data. (not as error)
- Aborted frame of HDLC/SDLC is not transmitted but a flag is transmitted in the place where aborted frame is generated.
- Information of Idle time in the buffer is not going to be used.
- Information of control line in the buffer is not going to be used. When the analyzer is DTE mode, RTS and DTR will be in an active state at the beginning of test. And, when the analyzer is DCE mode, CTS, DSR and DCD will be in an active state.

Press [STOP] to stop transmission and simulation.

## 4.6 Flow Mode

In the flow control test, the analyzer works as a transmitter or a receiver. It can simulate flow control signals such as X-ON/X-OFF characters and handshake of control line.

This is not available for the high-speed mode.



## Setting

Before starting the Flow simulation, set protocol and communication conditions in the “Configuration”, and register transmission data in the data table.



2.4 Communication Condition Settings



4.1 Register Transmission Data

Select “Flow” from “Mode” on the top menu screen and tap “Flow Opt.” to display the detailed settings screen for this function.

Select the test mode and set the test conditions.

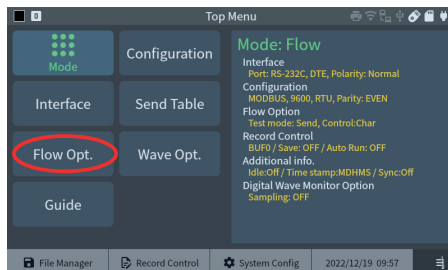

## ■ Test Mode

Select “Send” if analyzer becomes the transmitter. Select “Receive” if analyzer becomes the receiver.

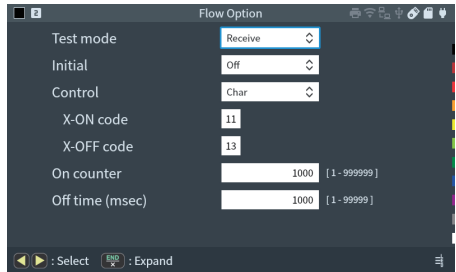
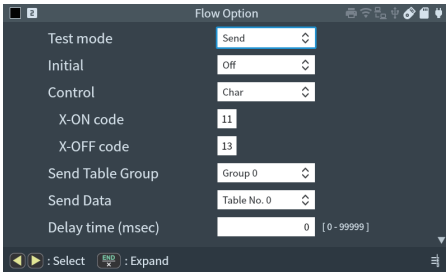

## ■ Initial

Initial state of flow control at the beginning of test.

Off : Prohibit transmission

On : Allow transmission

## ■ Control

Select the control method.

Char : X-ON/X-OFF character

Line : Handshake of control line.

## ■ X-ON/X-OFF code

Set X-ON/X-OFF character in HEX.

Normally, you do not have to change the initial value.

## ■ Watch/Operate

Set a pair of control line to allow transmission and request transmission. A pair of RTS and CTS is mostly used.

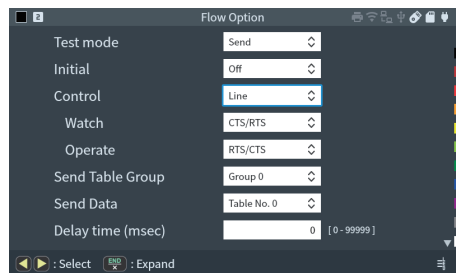

## ■ Control

Select a group of transmission data table.

## ■ Send Data

Select a transmission data table.

## ■ Delay time

Select the idle time. (0 to 99999ms)

■ On counter

The number of a reception character until interruption request is transmitted. (1~999999)

■ Off time

Time between interruption request and re-transmission request. (0 to 99999ms)



## Operation

Press [RUN] to start the flow control test.

○ “Send” with X-ON/X-OFF flow control

- 1) When the analyzer is DTE mode, RTS and DTR will become active. When the analyzer is DCE mode, CTS, DSR an DCD become active.
- 2) If the initial state is “ON”, it will start the data transmission immediately. If the initial state is “OFF”, it will start the transmission after receiving the X-ON character.
- 3) Transmission is interrupted when it receives X-OFF character. And transmission is re-started when it receives X-ON character.

○ “Send” with handshake flow control

- 1) When the analyzer is DTE mode, RTS and DTR will become active. When the analyzer is DCE mode, CTS, DSR an DCD become active.
- 2) Transmit selected data table repeatedly while the selected control line at “Watch/Operate” is active.

Transmission is interrupted when the selected control line is non-active. When the analyzer is DTE mode, CTS (or DCD) set at “Watch/Operate” is used. When the analyzer is DCE mode, RTS (or DTR) set at “Watch/Operate” is used.

During “send”, the number of data transmitted from starting to interrupting data transmission will be displayed on the screen for sixteen times.

(When it is over 999999, the message “Over flow” will be appeared.)



There might be some data transmitted after having the interruption of data transmission.

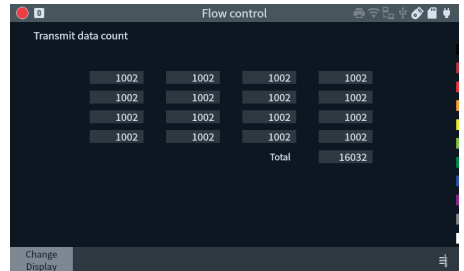

- “Receive” with X-ON/X-OFF flow control
  - 1) When the analyzer is DTE mode, RTS and DTR will become active. When the analyzer is DCE mode, CTS, DSR an DCD become active.
  - 2) If the “Initial state” is “ON”, it will start the data transmission immediately. If the “Initial state” is “OFF”, it will start the reception after the period of “OFF time” and receiving X-ON character.
  - 3) Transmit X-OFF character when it receives data is reached to the number set at “ON counter”. And transmit X-ON character when it passes the time set at “OFF time”.
  
- “Receive” with handshake flow control
  - 1) If the “Initial” is “On”, it will make the selected control line active immediately. If the “Initial state” is “OFF”, it will make the selected control line active after the period of “OFF time”. When the analyzer is DTE mode, RTS (or DTR) is used. When the analyzer is DCE mode, CTS (or DCD) is used.
  - 2) It makes the selected control line active when number of received data reaches to the number set at “ON counter”. And it makes the selected control line non-active after the period of “OFF time”.

During “Receive”, transmission/reception data are displayed on the screen at real time.

Press [STOP] to end the test.

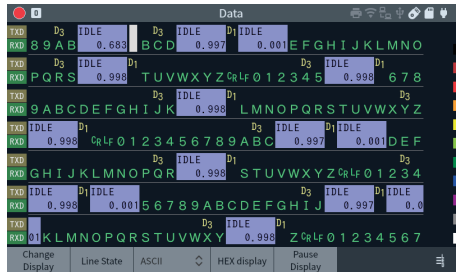

## 4.7 Echo back test (ECHO mode)

---

The echo back test is the function that makes received data repeatedly transmitted from the analyzer. This is not available for the high-speed mode.

This function cannot be used if protocol is set to I2C, SPI or Burst at “Configuration” setting.

 2.4 Communication Condition Settings

### Setting

---

Select “Echo” from “Mode” on the top menu screen and tap “Echo Opt.” to select the test mode.

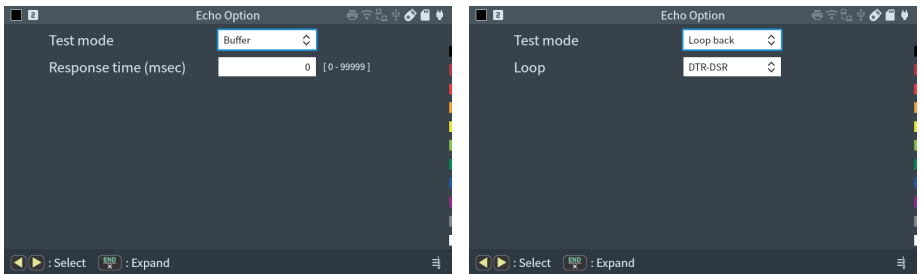

#### ■ Test mode

**Buffer** : Return the received frame with the time interval set at “Response”. (0 to 99999ms)

 10.3 About the Frame

**Char.** : Return the received frame after receiving a character.

**Loop back** : Loop back the signals of TXD-RXD, RTS-CTS, TXC1-RXC or selected control line at “Loop” (DTR-DSR or DTR-DCD).

 “Char.” is valid only for ASYNC protocol set at “Configuration” setting.

Press [RUN] to start the loop-back test.

**■ Buffer**

Return the received data per a frame according to the “Configuration” setting.

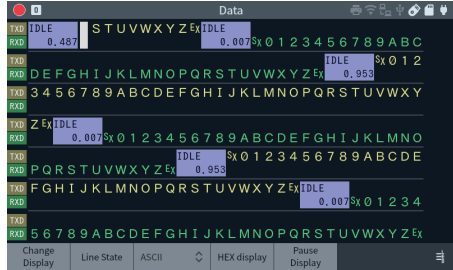

If it receives a new frame while it is in the “Response time” after receiving 1 frame, it can record max. 255 frames.

The actual response time may be longer than selected “response time”.

**■ Character**

Return the received data after receiving a character with data bit and Parity/MP bit. Data with framing error will be returned as normal data. (not as error)

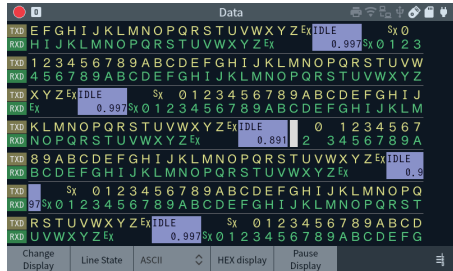

**■ Loop-back**

Loop back the signals in the hardware of analyzer according to the “Interface” setting.



Loop-back route :

For RS-232C and RS-530 (optional interface board OP-SB10N)

DCE (DSUB25pin)	DTE (DSUB25pin)
SD → connected in → RD internal circuit	RD → connected in → SD internal circuit
RTS → connected in → CTS internal circuit	CTS → connected in → RTS internal circuit
DTR → connected in → DSR*1 internal circuit	DSR*1 → connected in → DTR internal circuit
TXC1 → connected in → RXC1 internal circuit	RXC1 → connected in → TXC1 internal circuit

\*1 : The pair of control lines selected at “Loop”.

For RS-422/485

DCE (Terminal 5pin)	DTE (DSUB25pin)
TXD +- → connected in → RXD+- internal circuit	RXD+- → connected in → TXD +- internal cir

 In this case, full-duplex connection is used, so set “Driver control” in the interface settings to “Off”.

For TTL

DCE (TTL connector)	DTE (TTL connector)
TXD → connected in → RXD internal circuit	RXD → connected in → TXD internal circuit
RTS → connected in → CTS internal circuit	CTS → connected in → RTS internal circuit

## 4.8 Polling mode

---

In the polling mode, analyzer works as a slave station or a master station. And it replies message or analyzes the response when data corresponding to each situation is transmitted or received.

This is not available for the high-speed mode.



### Setting

---

Before starting the polling simulation, set protocol and communication conditions in the “Configuration”



#### 2.4 Communication Condition Settings

Select “Polling” from “Mode” on the top menu screen, tap “Polling Opt.”, select the test mode on the detailed setting screen of this function, and set the test conditions.



## Slave mode

In the slave mode, analyzer works as a slave station. When a station address is received, response message will be returned.

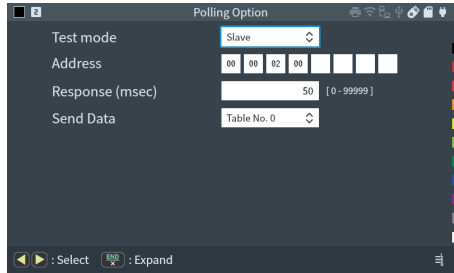

### ◆ Set following conditions

Item	Description	Range of Selection
Address	Station Address	Within eight characters in HEX
Response	Delay Time	0 ~ 99999ms 1msec. unit
Send Data	Transmission Table No	0 to F, or preset string

Address : Set a station address of analyzer.

Response : Set a delay time between receiving a message and sending a response message.

Table No. : Select a transmission data table registered a response message.



Register a response message in the transmission data table Group 0.



### 4.1 Register Transmission Data

#### <Operation>

- 1) Press [RUN], and control line (RTS/CTS for DTE mode, CTS/DSR/DCD for DCE mode) become active.
- 2) When a message is arrived, it searches a data sent to selfstation address.
- 3) If there is no message to self-station, it waits for a next message.
- 4) When there is a message to self-station, it receives the message. And then, response message will be returned after response time.

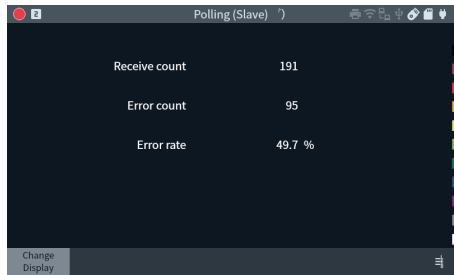

When a message to self-station is received, error check will be executed. (Even if there is an error, only message being set will be returned as a response message.).

Protocol	Description of Error Checking
ASYN	Parity Error, Framing Error, BCC Error
SYNC-BSC	Parity Error, BCC Error
HDLC-SDLC	FCS Error



## Master mode

In the master mode, analyzer works as a master station. And it transmits a polling message to each station address, and analyzes returned data.

### ■ Response

Set the time between receiving a message from slave station and sending a response message.

### ■ Time out

Set the timeout time when there is no response from a slave station. (0~99999ms)  
Set 0 to make no waiting time.

### ■ Repeat

Set the number of times to execute polling test. (0~9999 times)  
Set 0 to repeat continuously until [STOP] key is pressed.

### ■ Polling message

Set a polling message to transmit from analyzer (master station). Up to 15 characters in HEX can be set including don't care "\*" entered with [END/X]. And slave station address will be added to the position where don't care "\*" is entered in order of the minimum station number. To register slave station address, touch "station address" in the bottom of screen.

### ◆ Response map

Touch "Response map" on the bottom of screen. Set a response of slave station for polling message and how the analyzer operates by its response.

[A ⇒ B]

A : Set a transmission data table No. which is data compared with response message from slave station.

B : Set a transmission data table No. to send from the analyzer when response message from slave station matches A's contents.



In A, data registered in the transmission data table will be used as data compared with response message data. In this time, from the 1st to 23rd character of registered data will be effectively compared data.

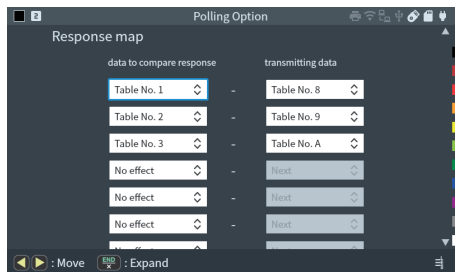
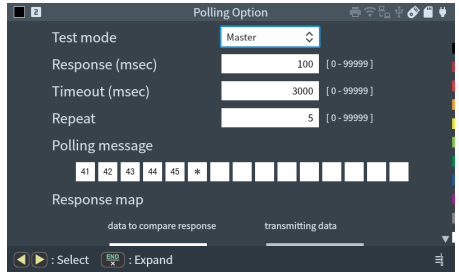

[Error ⇒ X]

When communication errors are generated in response message from slave station, selected transmission data table will be transmitted from the analyzer.

Protocol	Description of Error Checking
ASYNCR	Parity Error, Framing Error, BCC Error
SYNCR·BSC	Parity Error, BCC Error
HDLC·SDLC	FCS Error

[Time-out ⇒ X]

When waiting time for response (timeout) from slave station is passed, selected transmission data table will be transmitted from the analyzer.

- When “Next” is selected in B or X, it transmits nothing and polling will be executed to next slave station.
- When transmission data table is selected in B or X, the analyzer will be in a wait state for response from the same slave station.



#### 4.1 Register Transmission Data

##### ■ Station address

Tap “Station address” on the bottom of screen and set the slave station address to insert in polling message.

Max. 8 characters for one slave station address and 32 kinds of address can be set in HEX. Touch the tab or target slave address, or press [▲],[▼] to select different slave address.

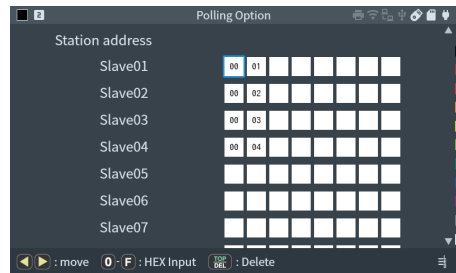

Slave station address is inserted to polling message in order of the minimum station No.



If nothing is registered in the slave station address, that station number will be ignored.

- <Operation> 1) Press [RUN] and control lines (RTS/CTS for DTE mode. CTS/DSR/DCD for DCE mode) become active. And then, polling simulation starts.
- 2) It operates corresponding to setting conditions and response from slave station like below.

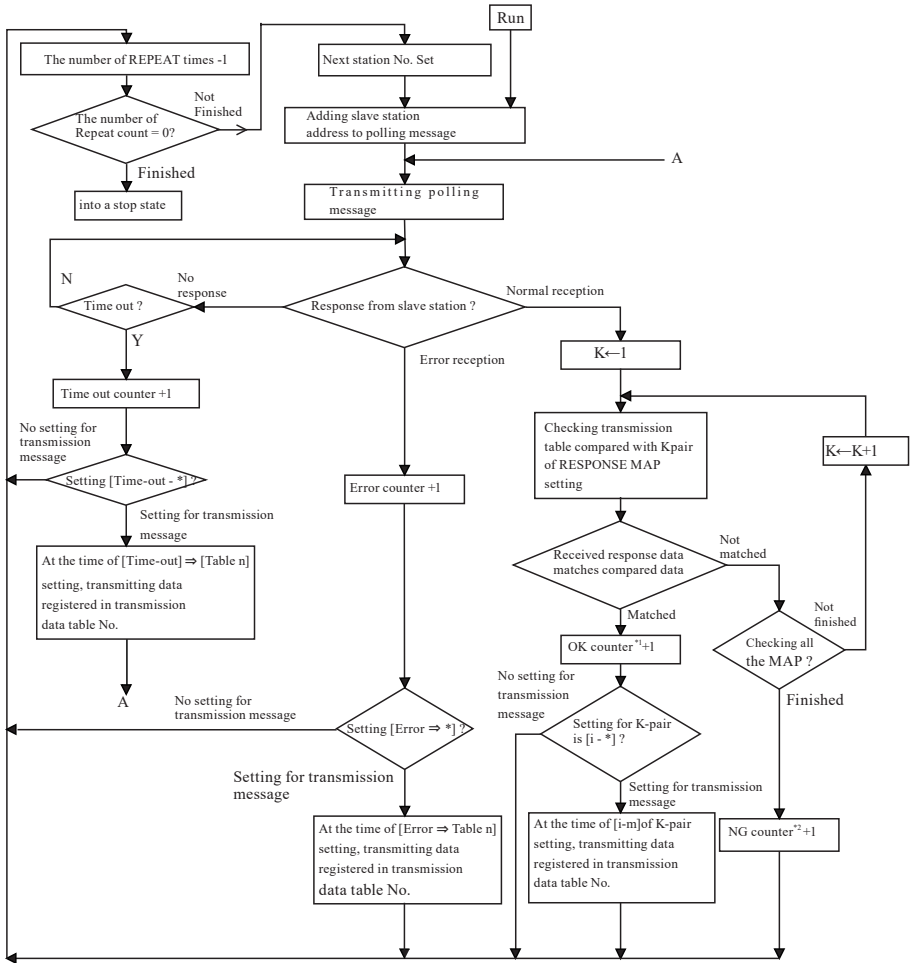

\*1 : Counter for OK-message. \*2 : Counter for NG-message.

3) It displays the result of each slave station. Swipe the screen or press [▲],[▼]to display all data.

Touch “Change display” to go back to normal monitored data display.

Station Address	OK-Msg	NG-Msg	Error	Timeout
1	36	19	0	5
2	35	19	0	6
3	35	19	0	6
4	36	18	0	6
5	36	18	0	6
6	0	0	0	0
7	0	0	0	0
8	36	18	0	5
9	0	0	0	0
10	0	0	0	0
11	0	0	0	0
12	0	0	0	0

OK-Msg : The number of received times for response message from slave station which matches compared data of response map.

NG-Msg : The number of received times for response message from slave station which does not match compared data of response map.

Error : The number of received times for response message with communication errors.

Timeout : The number of times of timeout generated.

## 4.9 Program mode

---

In the program simulation function, a simple program can be made by command-selected programming system. And transmission/reception sequences through each protocol are flexibly simulated.

This is not available for the high-speed mode.



### Outline

---

- Program

4 kinds (A~D) of the programs can be made.

- Program Steps

Up to 512 instruction steps for one program can be made.

- Number of Command

There are 37 kinds of the commands with the combination of commands and sub-commands. The destination linked with the command can be labeled. Therefore, modifying a program can be easily executed.

- Register

16 kinds of register (“REG 0”~ “REG F”) are provided in the range of 0 to 999999.

- Data Array

100 kinds of data array (“DA 00”~“DA 99”) can be made. Up to 8 characters can be recorded in each data array. Specify the data array No. by register value and compare reception data with data array

■ Transmission data table

Register transmission data table before starting the program simulation used for SEND TBL command and IF TBL command.

 4.1 Register Transmission Data

■ Timer

There are four timers of “TM 0-3” that are used when creating programs such as timeout processing using the IF TM command. And a comparison value and the time unit that can be set at [MENU], “Trigger”, “Timer/Counter” are used for them. Each timer can change the comparison value of the timer, start/stop the timer, etc. by the SET TM command. In addition to these, a dedicated timer for waiting time of 9.999 seconds (fixed in 1ms units) or less is provided for the WAIT TM command.

 6.2 Timer/Counter Function

■ Counter

There are four counters “CT 0-3” that are used when creating programs such as counting judgment processing using the IF CT instruction. And a comparison value of the counter that can be set at [MENU], “Trigger”, “Timer/Counter” are used for them. In addition, each counter can change the comparison value of the counter, count up, and clear operations with the SET CT command.

 6.2 Timer/Counter Function

■ Frame Buffer

A buffer memory exclusively used for recording received data in the unit of a frame (max. 4096 bytes) for WAIT FRM command. It is used to compare received data by IF TBL command.

■ Trigger condition

Before setting the commands of INT TRG0, WAIT TRG and IF TRG, set the trigger conditions from [MENU] -> “Trigger” -> “Trigger factor”.

 Only “Trigger factor” is used and “Trigger action” and invalid/valid of trigger are not used.

 6.1 Trigger Function

## Program input

Before starting the Program simulation, set the protocol and communication conditions in the “Configuration”.

### 2.4 Communication Condition Settings

Select “Program” from “Mode” on the top menu screen and tap “Program Edit” to display a screen to select a program (A to D). Select one of them and tap “Edit” to display the program input screen.

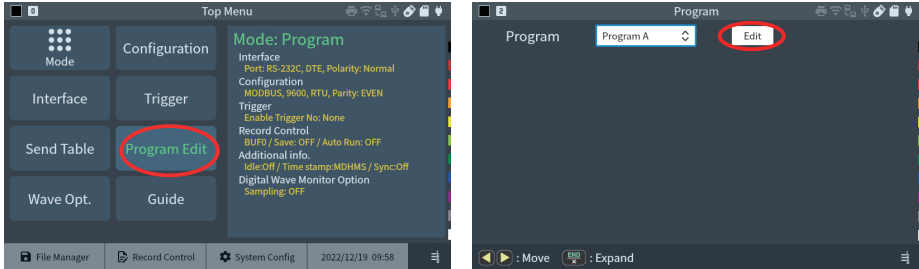

At the beginning, NOP commands (invalid command) are inputted in all 512 lines.

The cursor is on the first line, 000. To move the cursor, swipe the screen or press [▼],[▲]. To input the command, touch desired command on the right part of the screen or press [0]~[F].

 Press [SHIFT]+[▼] or [SHIFT]+[▲] to go to another page (move 10 lines).

 Press [SHIFT]+[TOP/DEL] to go to the first page, or [SHIFT]+[END/X] to go to the last page.

## ○ Input Method

### ◆ Command Field

Touch or press [0]~[C] to select a desired sub-command (SEND, WAIT, IF commands etc.) or [TOP/DEL] to delete commands. After deleting a command, the following commands comes up instead and NOP command is added at the end.

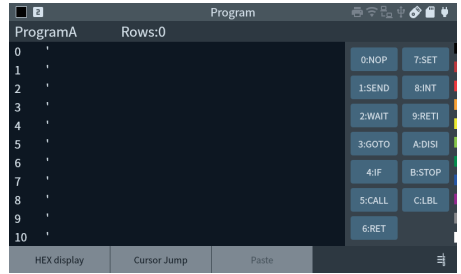

### ◆ Sub-Command Field

After the command field is entered, the cursor moves to the sub-command entry field. Desired sub-commands will be displayed in the right side of the screen. Touch or press [0] ~ [7] to select a desired sub-command. To edit the sub-command, move the cursor to the sub-command field by [◀] [▶] and edit.

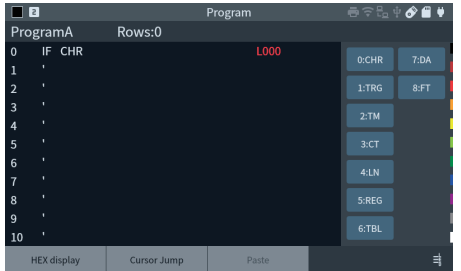

### ◆ Operand Field

When the subcommand part is entered, the cursor moves to the operand input position. Tap the operand option in the guide display area corresponding to the command or subcommand you entered, or enter the numeric value or character string of the operand from [0] to [F]. When all the operands are entered, the cursor automatically moves to the command part of the next line. If you want to modify the operand, move the cursor to the input position of the operand with [◀] [▶] and re-enter to change it.

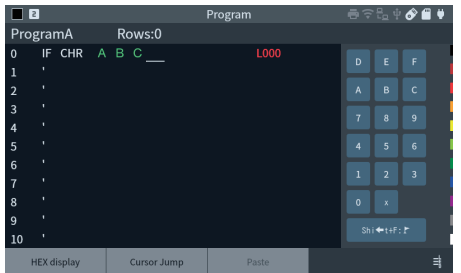

- Save program

Programs A to D that you created do not disappear even when the power is turned off. If you want to create more programs and select and use them, use a storage device to save and load them as setting data files.

 When the analyzer reads setting data files, program A ~ D will be overwritten.

 7.2 File Management Function

## Operation

Press [RUN] and programA ~ D will be executed from line 000.

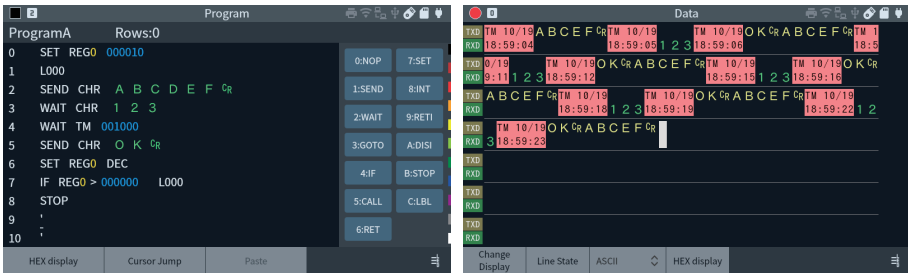

Send commands and received data from target device are displayed on the screen. It is able to analyze the protocol and sequence of transmission and reception.

By tapping “Change Display” until the timer/counter display, you can check the timer/counter value and register contents at that time.

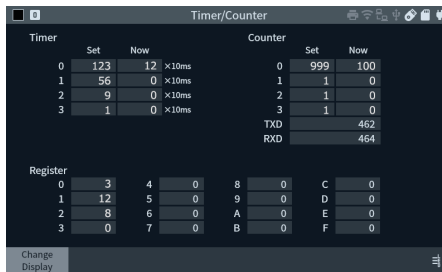

Timer/Counter					
Timer			Counter		
	Set	Now		Set	Now
0	123	12	0	999	100
1	56	0	1	1	0
2	9	0	2	1	0
3	1	0	3	1	0
			TXD	462	
			RXD	464	
Register					
0	3	4	0	8	C
1	12	5	0	9	D
2	8	6	0	A	E
3	0	7	0	B	F

 Amount of traffic and speed of communication changes the delay time between commands.

Press [STOP] and a running program will stop. Also, when the STOP command is executed, it will stop.

## 4.10 Commands for Program Mode

No	Command	Operation
0	NOP	No Operation. Go to next step.
1	SEND CHR □□□□□□□□	Data communications up to 8 characters.
	SEND TBL □□	Data transmission of the specified data send table.
	SEND REG □ GRP □	Data communications of the transmission data table specified by a register value.
	SEND BUF	Transmits data in the frame buffer.
	SEND KEY GRP □	Transmits data in the transmission data table corresponding to keystroke.
	SEND DA □□+REG□	Transmits data of the data array specified by additional value of preset value of the data array number and the value specified by register number.
	SEND BRK	Transmits a break. (ASYNC mode only)
	SEND FRM	Transmits a X.25 frame.
2	WAIT CHR □□□□□□□□	Waits for the particular character string of up to 8 characters to be received.
	WAIT FRM (CLR/NOCLR)	Waits for a frame to be received.
	WAIT TRG □	Waits for a specified trigger condition to be specified.
	WAIT TM □□□□□□	Waits for a specified period of time.
	WAIT KEY	Waits until one of the keys from [0] to [F] is pressed.
	WAIT LN □=□	Waits until the logical values of the control lines meet with the setting.
	WAIT MLT	After this, it executes consecutive WAIT commands at the same time. During the WAIT commands that are executed at the same time, all wait states are canceled when any of the conditions are satisfied.
3	GOTO L□□□	Jumps to a specified label number.
4	IF CHR □□□□□□□□ L□□□	Branches to a specified label number if the particular character string is included in the frame buffer.
	IF TRG □ L□□□	Branches to a specified label number if the trigger conditions are satisfied.
	IF TM □ L□□□	Branches to a specified label number if the timer exceeds the setting value.
	IF CT □ L□□□	Branches to a specified label number if the counter exceeds the setting value.
	IF LN □=□ L□□□	Branches to a specified label number if the logic values of control lines meet with the setting.
	IF REG□ □ REG□ L□□□	Branches to a specified label number if the inequality relation between registers is satisfied.
	IF TBL□□ L□□□	Branches to a specified label number if it is satisfied with data of table specified by the table number.
	IF DA □□+REG □ L□□□	Branches to a specified label number if the specified value of a data array number is same as the sum of the value of data array specified in the register number.

4	IF FT □□□□ L □□□	If the frame stored in the receive frame buffer matches the specified type, it branches to the line where the specified label is defined.
5	CALL L□□□	Jumps to a subroutine marked with a specified label number.
6	RET	Returns from the subroutine.
7	SET REG □ □□□□□□	Sets a value to register, or increments or decrements the register.
	SET LN □=□	Sets a value of the control line.
	SET TM □ □□□□□□	Sets a value to the timer, or controls the start, the stop or the restart of the program.
	SET CT □ □□□□□□	Sets a value to the counter, or increments or resets the counter.
	SET BZ	Sets the buzzer.
	SET OUT	Outputs a pulse to the trigger out terminal.
	SET DA □□ □□□□□□□□	Sets data to the data array.
	SET DV □□ REG□ □	Sets the specified number of characters on contents in register as a character string to the data array.
	SET MOD (8/128)	Sets the frame modulo for X.25-related processing in program simulation.
	SET AD □□□	Set the value of the address part of the frame sent by the SEND FRM command.
	SET VS □□□	Set or change the value of a V(S) state variable.
	SET VR □□□	Set or change the value of a V(R) state variable.
SET PF □	Set the P/F bit value of the frame sent by the SEND FRM command.	
SET DP □□□□	Sets or modifies a data pointer.	
8	INT TRG 0 L□□□	Jumps to the subroutine with the specified label number when the condition of trigger 0 is met.
9	RETI L□□□	Returns from subroutine started by the INT command.
A	DISI TRG 0	Disables an interruption.
B	STOP	Stops the running of simulation operation.
C	L□□□	Enters a label number in a range from 0 to 999 in decimal notation.



## NOP Command (Invalid Command)

The NOP command, which is displayed as “,” is the command that has no impact on the program execution.

<Entering>

Cursor Position	Enter & Operation
Command Field	0
Sub-Command Field	-
Operand Field	-

<Operation>

- When the program is running, the NOP command is ignored and the instruction of the next line number is executed.



## SEND Command (Data Transmission Command)

The SEND command is used to transmit data from your analyzer.

### 1) SEND CHR □□□□□□□□ (Character Line Transmission Command)

<Entering>

Cursor Position	Enter & Operation
Command Field	1
Sub-Command Field	0
Operand Field	Enter a string of up to 8 characters in hexadecimal code. To enter a string of less than 8 characters, finish the entry by pressing [▼] and proceed to the next line.

<Operation>

- The character string which is set in the operand field is transmitted. Use this command to transmit a short character string.
- Each protocol has different way of transmission. Refer to following table.

Protocol	Contents of Data Transmission
ASYNC	If the character string for transmission includes BCC calculation start and stop characters, the BCC code is inserted and transmitted automatically.
SYNC · BSC	The SYNC character and the RST character are automatically inserted to data and transmitted. In addition, if the character string for transmission includes BCC calculation start and stop characters, the BCC code is added automatically.
HDLC · SDLC	The flag and the FCS code are automatically inserted to data, and are transmitted.
ASYNC-PPP	If transmission data forms a frame, the FCS code is automatically inserted and transmitted.
MODBUS	Add BCC code automatically for RTU mode and transmit.

### 2) SEND TBL□□ (Data Table Transmission Command)

<Entering>

Cursor Position	Enter & Operation
Command Field	1
Sub-Command Field	1
Operand Field	Specify the table group in the 1st digit, and the table No. in the 2nd digit with 00 ~ 9F.

<Operation>

- Data, which is in the transmission data table on the number being set in the operand field, is transmitted.
- Use this command to send multi character strings.



3 ) SEND REG□ GRP□ (Register-Specified Data Table Transmission Command)

<Entering>

Cursor Position	Enter & Operation
Command Field	1
Sub-Command Field	2
Operand Field	Enter a register number with [0] to [F] keys and a table group number with [0] to [9] keys. By [END/X]:* (Don't care), all the groups will be the target.

<Operation>

- The transmission data table No. is specified with the register value 0 to 15 (F) being set in the operand field.  
And data with that number will be transmitted. The target table group number 0 to 9 is also set in the operand field. When the register value is over 16, remained transmission data table after dividing by 16, is specified.
- When “\*” is set to a table group, it directly selects by the register value (0 to 159). In this case, when register value is over 160, the remained value divided by 160 will be applied.
- If data without setting any data table is specified, no data is transmitted. Then, the next instruction will be executed.

4 ) SEND BUF (Frame Buffer Data Transmission Command)

<Entering>

Cursor Position	Enter & Operation
Command Field	1
Sub-Command Field	3
Operand Field	-

<Operation>

- Data stored in the frame buffer is transmitted.
- If no data is stored in the frame buffer, the next instruction is executed without sending any data.  
Before it is executed, the WAIT FRM command is required to execute in order to store data in the frame buffer

 Cannot send framing error, break or abort as itself.

5 ) SEND KEY GRP□ (Key-Specified Data Table Transmission Command)

<Entering>

Cursor Position	Enter & Operation
Command Field	1
Sub-Command Field	4
Operand Field	Enter a table group number by 0 to 9 keys.

<Operation>

- It waits until you press a key ([0] to [F]) and when you press the key it transmits the data of the transmission data table of the table group specified in the operand field. (The data to be transmitted corresponds with the key number you press.)When you specify a data table at which no data is set, it does not transmit data. Then it executes the next instruction.

6) SEND DA□□+REG\* (Data Array Transmission Command)

<Entering>

Cursor Position	Enter & Operation
Command Field	1
Sub-Command Field	5
Operand Field	Enter two digits of a data array number with the key, 0 to 9.
	Enter a register number with the key, [0] to [F]. Offset cannot be set by [END/X]: "*" (don't care).

<Operation>

- The Data array is set for the data array number in the operand field. And register value, which is set for the register number, is added as an offset value to that data array. After that, that value is as a data array number. And corresponding data of data array will be transmitted. If the result of the addition includes three digits, its last two digits are as data array numbers and corresponding data of data array is transmitted.
- When "\*" is set for a register number, data of the data array specified by the data array number is transmitted.  
If the "SEND DA xx" command is entered continuously, data registered in the data array is connected and transmitted.  
In this case, the size of transmission data is up to 1Kbytes. When it exceeds 1Kbytes, the excess of data will be omitted.
- If no data is registered in the data array set to the data array number, any data is not transmitted. And the next command is executed.
- Transmission data depends on the selection which is made on the Protocol as the "SEND CHR" command.

- Ex.) Transmit the contents (ABC) on DA33.  
DA33.  
000: Set 41h, 42h, 43h in HEX to DA33.  
001: Set 10 to REG4.  
002: Add DA number 23 and REG4 value 10 and send data.

```

ProgramA Rows:0
0 SET DA 33 A B C
1 SET REG4 000010
2 SEND DA 23 + REG4
3
4
5
6
7
8
9
10
    
```

- Ex.) Connect data from DA00 to DA02 and transmit (ABCDEFGHI)  
000: Set 41h, 42h, 43h in HEX to DA00.  
001: Set 44h, 45h, 46h in HEX to DA01.  
002: Set 47h, 48h, 49h in HEX to DA02.  
003: The "SEND DA" commands are entered continuously.  
004: Data registered in the DA 00 to 02 are connected.  
005: Transmit ABCDEFGHI.

```

ProgramA Rows:0
0 SET DA 00 A B C
1 SET DA 01 D E F
2 SET DA 02 G H I
3 SEND DA 00 + REG*
4 SEND DA 01 + REG*
5 SEND DA 02 + REG*
6
7
8
9
10
    
```

7) SEND BRK (Break Transmission Command)

<Entering>

Cursor Position	Enter & Operation
Command Field	1
Sub-Command Field	6
Operand Field	-

<Operation>

- Transmits a break. (ASYN mode only)

8) SEND FRM □□□□ TBL □(Transmits a X.25 frame)

<Input>

Cursor Position	Enter & Operation
Command Field	1
Sub-Command Field	7
Operand Field	Select frame type from 0 to 9
	Enter the data table number from 00 to 9F. With X, specifying turns out to be invalid.

<Action>

- Valid only when the protocol set in the configuration is HDLC.
- The address part of the frame to be sent uses the value set by the SET AD command, and the control part is specified by frame type, V(S) state variable (can be set by SET VS command), V(R) state variable (can be set with the SET VR command) and the transmission P/F value (can be set with the SET PF command). Data in the specified transmission data table is used for the data part. If “\*” is specified for the table number, a frame with an empty data part (no data part) is sent.
- FCS is automatically added when an item other than None is selected FCS item in the configuration settings. Therefore, when specifying the transmission data table, do not include FCS in it.
- If there is data being transmitted at the time the command is executed, the transmission will start after waiting until the transmission is completed. After transmission starts, command execution is completed without waiting for the completion of the command, and the program proceeds to the next command.
- If INFO is specified for the frame type, increment (add 1 to) the V(S) state variable when the command is completed (the upper bits of the result are masked based on the modulo)

◆ Data transmission and next command

When the SEND command is executed, it will start the command immediately before completing the previous data transmission. Set the WAIT FRM command (waiting for 1 frame) after SEND command as a response of transmitting data to read data in the frame buffer.

Ex.) SEND TBL 00  
WAIT FRM CLR

Some of the commands (such as new SEND, SET LN, SEND commands) cannot transmit data until finishing the previous data transmission. In this case, the program becomes a wait status.



## WAIT Command (Command to Halt Program Execution)

The WAIT command is used to halt the execution of a program until the particular conditions are satisfied.

If the “INT TRG” command interrupts this command, a wait state is canceled.

1 ) WAIT CHR□□□□□□□□ (Command to Wait for Character Reception)

<Entering>

Cursor Position	Enter & Operation
Command Field	2
Sub-Command Field	0
Operand Field	Enter a string of up to 8 characters in hexadecimal code. To enter the string of less than 8 characters, finish the entry by pressing ▼ and proceed to the next line. Additionally, “Don’t Care” (*) and a flag ( [SHIFT] + [F] ) are acceptable.

<Operation>

- Your analyzer halts the program control until the specific character string, which is previously set in the operand field, is received.
- When “Don’t Care” is set, your analyzer halts the program control until some character is received (This command does not use frame buffer).

2 ) WAIT FRM CLR

WAIT FRM NOCLR (Command to Wait for Reception of a Frame)

<Entering>

Cursor Position	Enter & Operation
Command Field	2
Sub-Command Field	1
Operand Field	Select 0: CLR or 1: NOCLR

<Operation>

- When the WAIT FRM command is executed, the dedicated frame buffer is deleted and initialized.
- It waits until recording 1 frame in the capture memory. After recording it, 1 frame from capture memory is captured in the frame buffer.
- Data in the frame buffer is not renewed until executing this command again.
- When the WAIT FRM CLR command is executed, the first 1 frame of data received in the capture memory is captured in the frame buffer. If it does not finish receiving 1 frame when the command is executed, the next one frame is captured.
- When the WAIT FRM NOCLR command is executed, the next frame captured by previous WAIT FRM command is captured.

<e.g.>

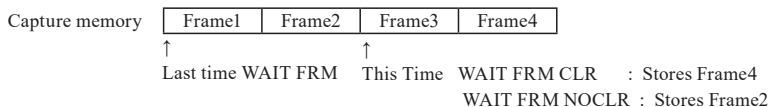

If one frame contains more than 4096 characters, it finishes capturing there and does not capture rest of data.

For ASYNC-PPP, it does not operate decoding of escape code and one frame of data is capture in the frame buffer.

10.3 About the Frame

Cannot use this command for I2C communication (half-duplex communication).

3) WAIT TRG□ (Command to Wait for Satisfaction of Trigger Conditions)

<Entering>

Cursor Position	Enter & Operation
Command Field	2
Sub-Command Field	2
Operand Field	Enter a trigger number with the key, 1 to 3 (Trigger 0 is not selectable).

<Operation>

- Your analyzer halts the program control until the condition, which is set for the trigger Factor specified in the operand field, is satisfied.
- Only trigger factors are used. Other information such as trigger valid/invalid and trigger action are not used.



WAIT TRG detects the turning point from unsatisfied to satisfied condition.



6.1 Trigger Function

4) WAIT TM□□□□□□ (Command to Wait for Designated Time)

<Entering>

Cursor Position	Enter & Operation
Command Field	2
Sub-Command Field	3
Operand Field	Enter waiting time in six digits decimal figures with the key, 0 to 9.

<Operation>

- Your analyzer halts the program control for setting time specified in the operand field in the unit of 1msec.

5) WAIT KEY (Command to Wait for Key Stroke)

<Entering>

Cursor Position	Enter & Operation
Command Field	2
Sub-Command Field	4
Operand Field	-

<Operation>

- Your analyzer halts the program control until one of the numerical keys from [0] to [F] is pressed. Whatever key is pressed down, the result is the same.

6) WAIT LN□=□ (Command to Wait for Meeting Control Line)

<Entering>

Cursor Position	Enter & Operation
Command Field	2
Sub-Command Field	5
Operand Field	Select signals from 0 : RTS, 1 : CTS, 2 : DSR, 3 : DCD, 4 : DTR, 5 : RI, 6 : TRG
	Select status from 0: non-active, or 1: active.

<Operation>

- Program control waits until the logic values of the control lines meet with the setting.

## 7) WAIT MLT command

< Input >

Cursor Position	Enter & Operation
Command Field	2
Sub-Command Field	6
Operand Field	-

< Action >

- Consecutive WAIT commands are executed at the same time. During the WAIT commands executed at the same time, all wait states are canceled when any of the conditions are met.
- Line up the WAIT commands (excluding the WAIT MLT command) that you want to execute at the same time following this command. Commands other than WAIT commands, including NOP commands, or immediately before another WAIT MLT command are subject to simultaneous execution.
- Combinations of WAIT commands that can be executed simultaneously have the following restrictions.

WAIT CHR	Up to 6 commands can be included together with the WAIT TRG command.
WAIT FRM	Can contain only one command.
WAIT TRG	Up to 6 commands can be included together with the WAIT TRG command. However, multiple commands that specify the same trigger number cannot be included.
WAIT TM	Can contain only one command.
WAIT KEY	Can contain only one command.
WAIT LN	One command can be included for each control line and external input.

If there are WAIT commands that exceed this limit, the excess WAIT commands are ignored.

When any condition is met and the wait state is released, the following value that indicates the WAIT command for which the condition was met is set to the special register ST.

100 ~ 105	1st to 6th WAIT CHR command
200	WAIT FRM command
301 ~ 307	WAIT TRG1 to WAIT TRG7 commands
400	WAIT TM command
500	WAIT KEY command
600	WAIT LN RTS command
601	WAIT LN CTS command
602	WAIT LN DSR command
603	WAIT LN DCD command
604	WAIT LN DTR command
606	WAIT LN RI command
607	WAIT LN TRG command

- If the conditions of multiple WAIT commands are met at the same time, the WAIT command placed earlier in the program has priority.
- If the standby state is canceled by an interrupt before the condition is satisfied, 0 is set in the special register ST.



## GOTO Command (Designated Label Number Branch Command)

The GOTO command branches the program control unconditionally to designated label number.

GOTO L□□□

<Entering>

Cursor Position	Enter & Operation
Command Field	3
Sub-Command Field	-
Operand Field	Enter a label number in three digits decimal figures with the key, [0] to [9].

<Operation>

- The program control branches to the instruction marked with the label number specified in the operand field.



## IF Command (Conditional Comparison Branch Control)

The IF command branches the program control to the designated label number if the particular conditions are satisfied. Or, it processes the next instruction if they are not satisfied.

1) IF CHR□□□□□□□□ L□□□ (Received Character Comparison Command)

<Entering>

Cursor Position	Enter & Operation
Command Field	4
Sub-Command Field	0
Operand Field	Enter a character string of up to 8 characters in hexadecimal code. To enter a string of less than 8 characters, finish the entry by pressing ▲ and move a cursor to the label entry section. Additionally, [END/X] “Don’t Care” (*) and a flag (  ) [SHIFT] +[F] are acceptable.
	Enter a label number in three digits decimal figures with the key, 0 to 9.

<Operation>

- WAIT FRM command searches the data in the frame buffer. And if the character string specified in the operand field is found, the program command branches to the designated label No.

2) IF TRG□ L□□□ (Judgment Command to Check Satisfaction of Trigger Conditions)

<Entering>

Cursor Position	Enter & Operation
Command Field	4
Sub-Command Field	1
Operand Field	Enter a trigger number with the key, [1] to [3] (Trigger 0 is not selectable).
	Enter a trigger number with the key, [1] to [3] (Trigger 0 is not selectable).

<Operation>

- The program control branches to the designated number if the conditions for the Factor of the trigger specified in the operand field are satisfied.
- Only trigger factors 1~3 are used. Other information such as trigger valid/invalid and trigger action are not used.

Factor	Judgment Content
Error	Data in the frame buffer is checked to see if the conditions are satisfied.
Character	
Line state	The conditions are checked to see if it is satisfied when the command is executed.
Timer/Counter	Does not perform anything. The next command is executed unconditionally.
Idle time	he conditions are checked to see if it is the condition value or over when the command is executed.

 6.1 Trigger Function

### 3) IF TM□ L□□□ (Judgment Command on Timer)

<Entering>

Cursor Position	Operand Field
Command Field	4
Sub-Command Field	2
Operand Field	Enter a timer number with the key [0] to [3].
	Enter a label number in three digit decimal figures with the key, [0] to [9].

<Operation>

- The program control branches to the designated label No. if the value of the timer No. specified in the operand field is over the preset value.

 6.2 Timer/Counter Function

### 4) IF CT□ L□□□ (Judgment Command on Counter)

<Entering>

Cursor Position	Enter & Operation
Command Field	4
Sub-Command Field	3
Operand Field	Enter a counter number with the key [0] to [3]
	Enter a label number in three digit decimal figures with the key, [0] to [9].

<Operation>

- The program control branches to the designated label No. if the value of the counter No. specified in the operand field is over the preset value.

 6.2 Timer/Counter Function

### 5) IF LN□=□ L□□□ (Judgment Command on Control Line)

<Entering>

Cursor Position	Enter & Operation
Command Field	4
Sub-Command Field	4
Operand Field	Select signals from 0 : RTS, 1:CTS, 2:DSR, 3:DCD, 4:DTR, 5:RI, 6 :TRG
	Select status from 0: non-active, or 1: active.
	Enter a label number in three digit decimal figures with the key, [0] to [9].

<Operation>

- The program control branches to the designated label number if the logic of the control lines specified in the operand field meets with the setting.

6) IF REG□ □ REG□ L□□□ (Judgment Command on Register Value)

<Entering>

Cursor Position	Enter & Operation
Command Field	4
Sub-Command Field	5
Operand Field	Operand Field
	Input the inequality by 0 : = , 1 : ≠ , 2 : < , 3 : > , 4 : ≤ , 5 : ≥
	Enter the label number in three digits decimal figures with the key, [0] to [9].

<Operation>

- The program control branches to the designated label, if the inequality relation between registers of operand filed is satisfied.



If you want to compare the contents of a register with a constant value, execute this command after setting the constant value in another register by using the SET command.

7) IF TBL□ □ L□□□ (Judgment Command on Data Table Comparison)

<Entering>

Cursor Position	Enter & Operation
Cursor Position	4
Sub-Command Field	6
Operand Field	Operand Field: Specify the table group in the 1st digit, and the table No. in the 2nd digit with 00~9F
	Enter the label number in three digits decimal figures with the key, [0] to [9].

<Operation>

- The program control branches to the designated label number if data satisfied up to 23 characters from the top of data, which is registered in the specified data table in the operand field, is detected in the frame buffer by the WAIT FRM command.
- Parity bit is not a object to be compared.



4.1 Register Transmission Data

8) IF DA □□+REG□ L□□□ (Judgment Command on Data Array Comparison)

<Entering>

Cursor Position	Enter & Operation
Command Field	4
Sub-Command Field	7
Operand Field	Operand Field: Specify the data array No. with the key, 0 to 9.
	Enter a data array number with the key, [0] to [F]. [END/X]: * (Don't Care) allows the offset to be invalid.
	Enter the label number in three digits decimal figures with the key, [0] to [9].

<Operation>

- The program control branches to the designated label number if data, satisfied with data being set in the specified data array in the operand field, is detected in the frame buffer.
- The method of designating a data array number is the same as that of “SEND DA Command.”

9) IF FT □□□□ L □□□ ( Receive frame buffer judgment command)

<Input>

Cursor Position	Enter & Operation
Command Field	4
Sub-Command Field	8
Operand Field	Select a frame type with the key, 0 to 9
	Enter a label number in three digits decimal figures with the key, 0 to 9.

<Action>

- When the frame stored in the receive frame buffer matches the specified type, it branches to the line where the specified label is defined.  
(Specify one of “INFO”, “RR”, “RNR”, “REJ”, “DM”, “SABM”, “SABME”, “DISC”, “UA”, or “FRMR”)
- When the WAIT FRM command has never been executed, or when the executed WAIT FRM command is executed after the wait state has been canceled before data is stored due to an interrupt, etc., the condition is always not met regardless of the specified type.



## CALL Command (Subroutine Call Command)

---

The CALL command is used to call a subroutine.

CALL L□□□

<Entering>

Cursor Position	Enter & Operation
Command Field	5
Sub-Command Field	-
Operand Field	Enter the label number in three digits decimal figures with the key, [0] to [9].

<Operation>

- program control branches to the subroutine that is marked with the label number specified in the operand field. The subroutine can be nested up to 100 folds.



## RET Command (Command to Return from Subroutine)

---

The RET command is used to return from the subroutine to the main routine.

RET

<Entering>

Cursor Position	Enter & Operation
Command Field	6
Sub-Command Field	-
Operand Field	-

<Operation>

- The program control returns from the subroutine to the main routine. This command must be set to the end of the subroutine.



## SET Command (Device Setting Command)

---

The SET command is used to control timers, counters, and registers and to preset values for them. Also, it is used to preset the logical values of the control lines, and to control the buzzer and external trigger output.

1) SET REG□ □□□□□□ (Register Preset Command)

<Entering>

Cursor Position	Enter & Operation
Command Field	7
Sub-Command Field	0
Operand Field	Enter a register number with the key, [0] to [F].
	Enter a preset value of the register in six digits decimal figures with the key, [0] to [9]. Or, Specify either increment or decrement with the key A or B.

<Operation>

- The content of the register specified in the operand field is changed.

Register Preset Value	Setting Condition
Six Digits Decimal Figure	The preset value is entered in the register.
A	1 is added to the register contents "INC".
B	1 is subtracted from the register contents "DEC".

- When the program starts, all the registers will be set 000.





## 2 ) SET LN□=□ (Control Line Logic Setting Command)

<Entering>

Cursor Position	Enter & Operation
Command Field	7
Sub-Command Field	1
Operand Field	0 : RTS, 1 : CTS, 2:DSR, 3:DCD, 4:DTR, 5:RI, 6 : TRG
	Select status from 0: non-active, or 1: active.

<Operation>

- The control line specified in the operand field is set to the specified state.

-  The control line is set to mark state ("0") when the program starts.
-  The settable control line is subject to the condition of DTE/DCE of your analyzer.
-  If the "auto line control" is "ON", the conditions of RTS/DTR/CTS/DCD are changed without being related to this command. Normally, set "OFF"
-  RI operates in the V.35 mode only.

## 3 ) SET TM□ □□□□□ (Timer Control Command)

<Entering>

Cursor Position	Enter & Operation
Command Field	7
Sub-Command Field	2
Operand Field	Enter a timer number with the key, [0] to [3].
	Enter a preset value of the timer in six digits decimal figures with the key, 0 to 9. Or, specify start, stop, and restart with the key, A to C.

<Operation>

- The preset value, which is compared with measurement value, is set to the timer specified in the operand field. Moreover, the timer operation is controlled.

Preset Timer Value	Setting Condition
Six Digits Decimal Figures	Set a preset value.
A	Starts the timer (START).
B	Stops the timer (STOP).
C	Restarts the timer [clear to 0 and start] (RESTART).

- Set the unit of timer and the comparison value in the timer/counter setting from the top menu.

 6.2 Timer/Counter Function

4) SET CT□ □□□□□ (Counter Control Command)

<Entering>

Cursor Position	Enter & Operation
Command Field	7
Sub-Command Field	3
Operand Field	Enter a counter number with the key, [0] to [3].
	Enter a preset value of the counter in six digits decimal figures with the key, 0 to 9. Or, specify increment or reset with the key( A, B) .

<Operation>

- The preset value, which is compared with measurement value, is set to the counter specified in the operand field. Moreover, the counter operation is controlled.

Register Counter Value	Setting Condition
Six Digits Decimal Figures	Sets the preset counter value.
A	Adds 1 to the counter (INC).
B	Clears the counter (RESET).

- Set the unit of timer and the comparison value in the timer/counter setting from the top menu.

 6.2 Timer/Counter Function

5) SET BZ (Buzzer Control Command)

<Entering>

Cursor Position	Operand Field
Command Field	7
Sub-Command Field	4
Operand Field	-

<Operation>

- Buzzer sounds.

6) SET OUT (Trigger Out Output Command)

<Entering>

Cursor Position	Enter & Operation
Command Field	7
Sub-Command Field	5
Operand Field	-

<Operation>

- The output pulse is delivered to the trigger out terminals (L level output for about 1mS).

 If this command is executed again during outputting the pulse, it extends L level for about 1ms.

7) SET DA□□ □□□□□□□□ (Data Array Setting Command)

<Entering>

Cursor Position	Enter & Operation
Command Field	7
Sub-Command Field	6
Operand Field	Operand Field: Specify 2 digits of data array number with the key, 0 to 9.
	Enter a string of up to eight characters in hexadecimal code. To enter a string of less than eight characters, finish the entry by pressing ▼ and proceed to the next line.

<Operation>

- The specified character strings are set to the data array of the designated number.

8 ) SET DV□□ REG□ □ (Data Array Setting Command)

< Input>

Cursor Position	Enter & Operation
Command Field	7
Sub-Command Field	7
Operand Field	Operand Field: Specify 2 digits of data array number with the key, 0 to 9.
	Input the set-register number with the key, 0 to F.
	Enter the digit number of a character with the key, 0 to 6. A (BYTE): Set the lowest 8bit of specified register to the data array. B (W-LE): Set the lowest 16bit of specified register to the data array as "little endian". C (W-BE): Set the lowest 16bit of specified register to the data array as "big endian".

<Operation>

- Set the contents of specific register in the data array as data strings.

e.g.) Transmitting REG0 value 12 as a character string of five digits

- 1) Set 12 to REG0.
- 2) Change 12 into a character string of five digits. And set it to DA00.
- 3) Transmit DA00 (00012).



9 ) SET MOD □□□

<Entering>

Cursor Position	Cursor Position
Command Field	7
Sub-Command Field	8
Operand Field	Specifies the modulo of the X.25 frame (0 for modulo 8, 1 for modulo 128).

<Operation>

- The initial state is modulo 8.

10 ) SET AD □□ H / SET AD REG □

<Entering>

Cursor Position	Cursor Position
Command Field	7
Sub-Command Field	9
Operand Field	Enter a 2-digit hexadecimal setting value from 0 to F, or set a register with SHIFT+0.
	If you set a register with SHIFT + 0, enter the register number with 0 to F.

< Action>

- Set the value of the address part of the frame to be sent by the SEND FRM command.

SET AD nnH

Sets the constant value specified at the address.

SET AD REGm

Sets the value of the register specified at the address. If the value of the register is 256 or more, the remainder obtained by dividing that value by 256 is set.

11 ) SET VS □□□ / SET VS REG □

<Entering>

Cursor Position	Enter & Operation
Command Field	7
Sub-Command Field	A
Operand Field	Input a 3-digit decimal setting value (000 to 127) with 0 to 9, or input increment with A, decrement with B, and set the register value with C.
	When you set a register value, enter the register number from 0 to F.

< Action>

- Set or change the value of the V(S) state variable.

SSET VS vvv Sets the constant value specified to the V(S) state variable.

SET VS INC Increments (adds 1 to) the value of the V(S) state variable.

SET VS DEC Decrements (subtracts 1 from) the value of the V(S) state variable.

SET VS REGn Sets the register value specified to the V(S) state variable.

- The value of the V(S) state variable to be set and updated is masked with higher bits based on the modulo setting.
- The V(S) status variable is used as the value of the N(S) field of the frame sent by the SEND FRM command.

12 ) SET VR □□□ / SET VR REG □

<Entering>

Cursor Position	Enter & Operation
Command Field	7
Sub-Command Field	B
Operand Field	Input a 3-digit decimal setting value (000 to 127) with 0 to 9, or input increment with A, decrement with B, and set the register value with C.
	When you set a register value, enter the register number from 0 to F.

< Action>

- Set or change the value of the V(R) state variable.

SET VR vvv Sets the constant value specified to the V(R) state variable.

SET VR INC Increments (adds 1 to) the value of the V(R) state variable.

SET VR DEC Decrements (subtracts 1 from) the value of the V(R) state variable.

SET VR REGn Sets the register value specified to the V(R) state variable.

- The value of the V(R) state variable to be set and updated is masked with higher bits based on the modulo setting.
- The V(R) status variable is used as the value of the N(R) field of the frame sent by the SEND FRM command.

13) SET PF □

<Entering>

Cursor Position	Enter & Operation
Command Field	7
Sub-Command Field	C
Operand Field	Input the setting value with 0 or 1

<Operation>

- Set the value of the P/F bit of the frame to be sent with the SEND FRM command.

14) SET DP □□□□ / SET DP REG □

<Entering>

Cursor Position	Enter & Operation
Command Field	7
Sub-Command Field	D
Operand Field	Input a 4-digit decimal number setting value (000 to 4095) with 0 to 9, or input increment with A, decrement with B, and set the register value with C.
	When you set a register value, enter the register number from 0 to F.

< Action>

- Set or change the data pointer.

SET DP vvv

Sets the specified constant value to the data pointer.

SET DP INC

Increments (adds 1 to) the data pointer. However, if the original value is 4095, the value remains unchanged.

SET DP DEC

Decrements (subtracts 1 from) the data pointer. However, if the original value is 0, the value remains unchanged.

SET DP REGn

Sets the value of the specified register to the data pointer.

If the register value is 4096 or greater, 4095 is set.

- The data pointer DP is a pointer that determines the position of the data referenced by the special register DT. It is offset with the position of the first data in the frame as 0 (excluding special data such as flags).



## INT Command (Trigger Interrupt Command)

The INT command monitors whether or not the conditions of trigger 0 are satisfied while the program is running.

And when the conditions are satisfied, the program control branches to the designated label number.

INT TRG0 L□□□

<Entering>

Cursor Position	Enter & Operation
Command Field	8
Sub-Command Field	-
Operand Field	Enter a label number in three digits decimal figures with the key, 0 to 9.

<Operation>

- On executing this command, the conditions of trigger 0 are monitored to check if they are satisfied while the program is running. When the conditions are satisfied, the command during operating is completed. Then, the program control branches to the designated label number specified in the operand field. However, if your analyzer has been in a wait state by the WAIT command, this state will be cancelled by the INT command. Moreover, the WAIT command branches as an inoperative command during operating.
- Trigger conditions are not monitored while the destination subroutine of the branches is being executed.

Monitoring is resumed when the RETI command returns the program control from the subroutine to the main routine. The following two things are all ignored. One is the valid and invalid condition for the specified trigger. The other is the content being set for “Action”

- Only trigger factors are used. Other information such as trigger valid/invalid and trigger action are not used.



### 6.1 Trigger Function

- ◆ Set more than one INT commands

If more than one INT commands are set and they branch to different labels, only the latest INT command is operated. (The INT command has to be executed before satisfying the trigger condition.)

- ◆ Set “line state” for trigger factor “0”

If “line state” is set for trigger factor “0” of INT command, it branches to the label when INT command is executed and line state is changed its status. (non-matched -> matched)



## RETI Command (Trigger Interrupt Reset Command)

---

The RETI command returns the program control to the main routine from a subroutine which the program control is branched to by the INT command.

RETI L□□□

<Entering>

Cursor Position	Enter & Operation
Command Field	9
Sub-Command Field	-
Operand Field	Operand field: input 3 digits of label number with the key, 0 to 9. Or input "don't care" (*) by [END/X].

<Operation>

- The program control returns to the main routine from a subroutine which the program control is branched to by the INT command. If the label number of three digits is entered in the operand field, the main routine is restarted at the instruction marked with the label number. If "Don't Care" is entered in the operand field, the main routine is restarted at the instruction next to that which is being executed before branching by the INT command.

◆ Return point during wait status

When the WAIT command is executed and it becomes the waiting status, next command after WAIT command is executed if the program is branched by the INT command after trigger condition 0 is satisfied and the returned point of REIT command is "don't care".

More over, it is possible that frame buffer becomes empty when WAIT FRM command is branched to wait status and no command is executed.



## DISI Command (Trigger Interrupt Disable Command)

---

The DISI command disables branching when trigger conditions are satisfied after executing the INT command.

<Entering>

Cursor Position	Enter & Operation
Command Field	A
Sub-Command Field	-
Operand Field	-

<Operation>

- The branch of programs on satisfaction of trigger conditions is disabled.
- To enable branching, execute the INT command again.



## STOP Command (Program Quitting Command)

---

The STOP command stops a running program.

<Entering>

Cursor Position	Enter & Operation
Command Field	B
Sub-Command Field	-
Operand Field	-

<Operation>

- The program simulating operation is stopped. And then, the analyzer stops measuring.



## LBL Command (Command to Define Label)

The LBL command defines the destination of a branch command.

L□□□

<Entering>

Cursor Position	Enter & Operation
Command Field	C
Sub-Command Field	-
Operand Field	Enter a label number in three digits decimal figures with the key, 0 to 9

<Operation>

- The LBL command defines a branch destination of the following commands: GOTO, IF, CALL, INT and RETI.
- The LBL command has no effect on the operation as the NOP command.

### ■ Sample Program

The program shown below transmits data in the data table 00. If the AK characters (06h) are received, it transmits OKCR and resend. If an error is received, it transmits data in the data table 01 and resend after 500ms waiting time. Or, if no response is received within 3 seconds, it transmits data in the data table 02 and resend.

After that, the program will stop.

```

SET TM0 003000      ..... Sets three seconds to timeout.
INT TRG0 L004      ..... Executes the INT command (Monitoring timeout)
,
L001
SET TM0 RESTART    ..... Restarts timer 0.
SEND TBL00         ..... Transmits data in the data table 00.
WAIT FRM CLR       ..... Waits for receiving a signal of one frame.
SET TM0 STOP       ..... Stops timer 0.
IF TRG1 L003       ..... Judges errors.
IF CHR AK L002     ..... Judges AK characters(06h).
GOTO L001          ..... Branches to retransmission process.
,
L002
SEND CHR O K CR    ..... Stops the program.
GOTO L001         ..... Branches to retransmission process.
,
L003
SEND TBL01         ..... Transmits data in the data table 01.
WAIT TM 0500      ..... Wait 500ms
GOTO L001         ..... Branches to retransmission process.
,

```

```

L004
SEND TBL02          ..... Transmits data in the data table 02.
RETI L005          ..... Branches to the end of the program.
,
L005
STOP

```

<Other setting >

Data table 01:0123456789 C<sub>R</sub>

Data table 02:NG C<sub>R</sub>

Data table 03:TIMEOUT C<sub>R</sub>

Factor of trigger “0”: Timer/Counter

Timer/Counter setting: Timer 0, comparison value: 3000, resolution: 1ms

Factor of trigger “1”: error

< Example of above program >

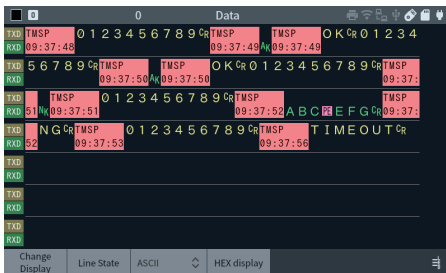

# 4.11 Pulse Generator Mode (PULSGEN)

Generate the waveform measured by the Timing waveform function. Also, it can edit the data and have various kinds of tests, such as sending at different timing.

## Preparation

Measure and record the waveform using the Timing waveform function, which you would like to generate later.

### 6.3 Timing Waveform Measurement Function

- Waveform data with a sampling clock of 5ns cannot be used in waveform output mode, so set the sampling clock to 10ns or more to record the timing waveform.

## Capture waveform

Select “PULSGEN” from “Mode” on the top menu screen and tap “PULSGEN Opt.” to display the waveform edit screen.

[Shift]+ “Import” to import the waveform.

- The signal being edited is displayed with a green background color.
- Press [SHIFT]+[▲] to select the signals upward.  
Press [SHIFT]+[▼] to select the signals downward.
- Swipe to scroll the waveform data.



## Edit waveform

Press [▲] or [▼] on the edit screen to move the target signal, and press [◀] or [▶] to move the cursor.

### 1) Waveform inversion

By tapping “Invert”, you can invert the logic of the target signal after the cursor.



Before inversion



After inversion

## 2) Insertion

Tap “Shift Mode” to enter shift mode, then press [ ▶ ] to insert the same signal (1 timing) on the right side of the cursor.

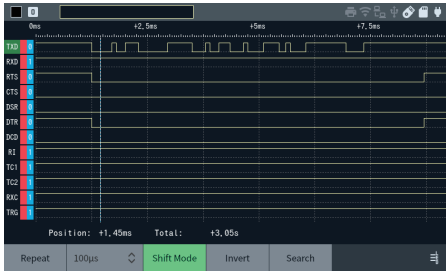

Before insertion



After insertion

## 3) Deletion

Tap “Shift Mode” to enter shift mode, then press [ ◀ ] to delete the signal (1 timing) on the right side of the cursor.



Before deletion

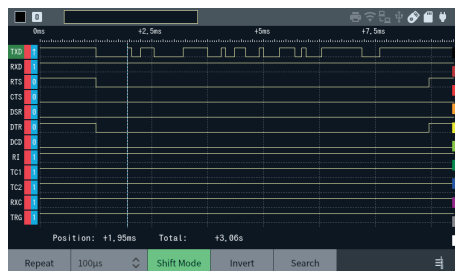

After deletion

## 4) Search

Tap “Search” to enter search mode.

The right side of the target signal name is the search condition, and set [0], [1], '↑' (rising edge), '↓' (falling edge), [END/X] (not specified).

In search mode, use [ ▶ ], [ ◀ ] to move the cursor to a location that matches the conditions.

Tap “Search” again to exit search mode.



### 5) Setting the waveform data output clock

On the waveform edit screen, tap the waveform data output clock to select it.

### 6) Repeating output setting

On the waveform edit screen, tap Repeat to select it.

When Repeat is selected, waveform data will continue to be sent repeatedly.

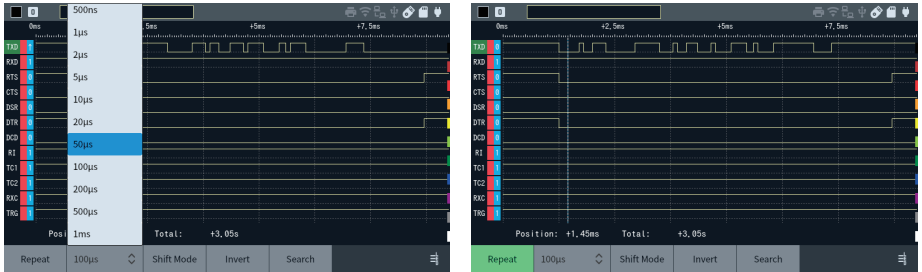

## Operation

Press [Run] to reproduce the waveform data according to the waveform data output clock settings on the waveform edit screen.



The waveform will not be affected by the configuration (communication conditions).

# Chapter 5 BERT Function

The analyzer has the function to send a test pattern and the function to compare the received data with the test pattern. By a loopback test or a face-to-face test, the quality of the data communication line including the modem etc. can be evaluated and the failure point of the data communication line can be isolated.

## 5.1 Connection and Settings

Select the measurement port according to the interface to be tested, and connect as follows according to the test method.

 2.3 Measurement Port

### Loopback test

The test pattern data sent from this unit is looped back and tested at each point on the communication line. You can evaluate the round-trip communication line that goes through each loopback point and can isolate the failure point by changing the loopback point.

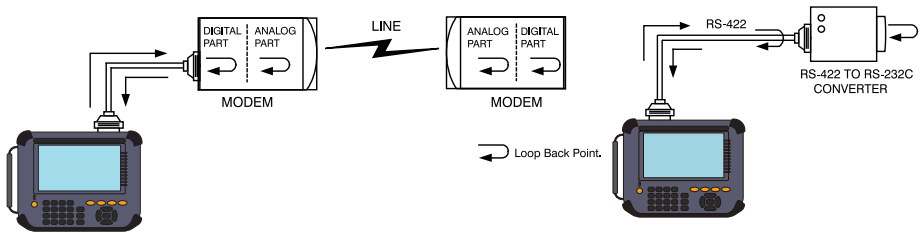

 Setting and switching of the loopback point in the device under test such as a model may be possible using the self-test function of the device under test. If you cannot loop back inside the device, loop back at the connector.

## End-to-End Test

The end-to-end test is a test in which a device with the BERT function as this unit has is connected to the other party and the same test pattern is sent and received each other. This test allows you to evaluate the transmit line and receive line separately.

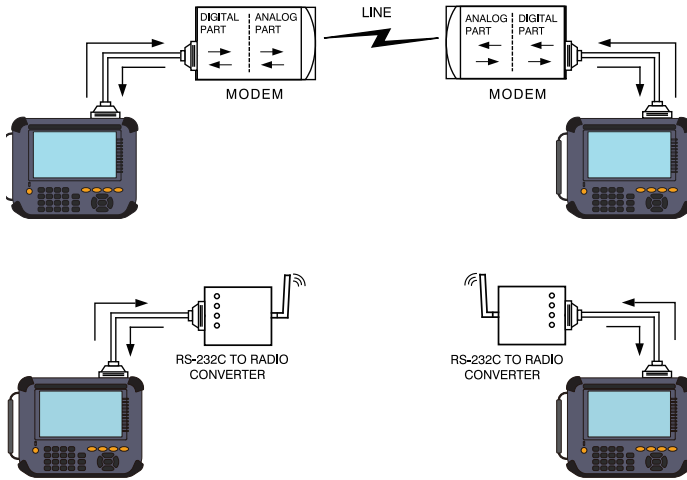

## Setting of Test Mode

The BERT function works in either asynchronous or synchronous communication. First, set the protocol, communication speed, etc. in “Configuration” at the top menu.

### 2.4 Communication Condition Settings

- When testing asynchronous communication

Set the protocol “ASYNC”. It is tests at the speed set by “TXD speed” and “RXD speed”, and the test pattern is divided into the bit length specified by “Data bit”, and the start bit and the stop bit specified by “Stop bit” are added. Other settings such as “parity” are meaningless and invalid in the BERT function.

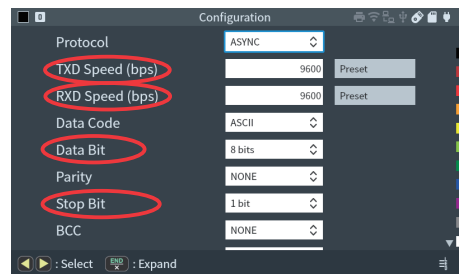

-  The added start bit and stop bit are not measured.

- When testing synchronous communication

Set the protocol “SYNC / BSC”. It is tests at the speed set by “TXD speed” and “RXD speed”, and the test pattern is sent and received by the synchronous clock specified by “Clock”. The character sync setting is used for convenience. No SYNC code is added to the test pattern, and the other setting items are meaningless and invalid with the BERT function.

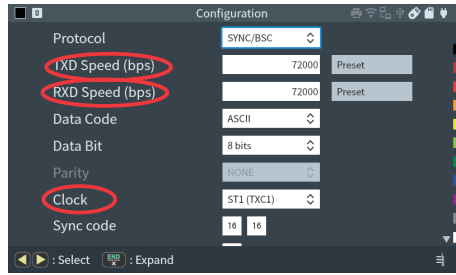

Next, set the BERT test mode and test pattern.

Tap “Mode” -> “BERT”-> “BERT Opt.” from top menu and set BERT settings.

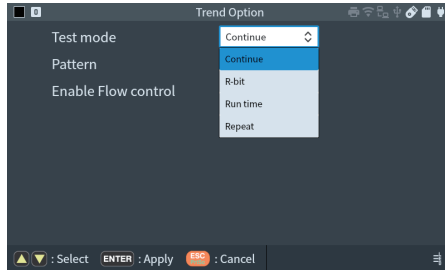

### ■ Test mode

Select the operation mode of BERT.

Continue : It continues measurement until a stop operation for measurement.

R-bit : It continues the test until the effective received bit number reaches the value specified at “Count”.

Run time : After establishing synchronization at first, it continues the test for the specified seconds set at “Test time” (maximum: 9999999 seconds).

Repeat : It repeats measurement up to max.2000 times for each time set at “Resolution” (1 to 1440 minutes).

📖 The receive bit is exponential. For example, 1.0E5 = 100,000.

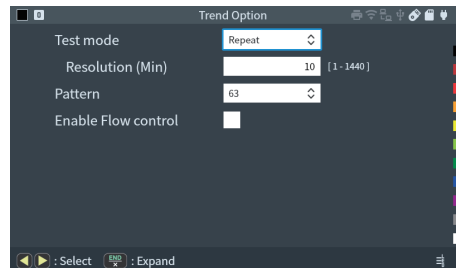
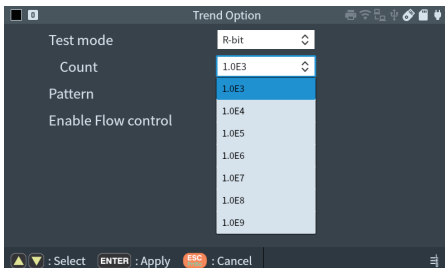

■ Pattern

Select the test pattern data to be sent/received.

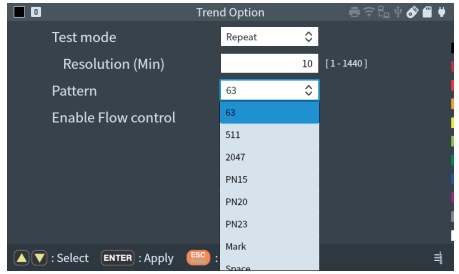

Name	Content
63	$2^6 - 1$ ( Generator polynomial $X^6 + X + 1$ ) Random code
511	$2^9 - 1$ ( Generator polynomial $X^9 + X^4 + 1$ ) Random code
2047	$2^{11} - 1$ ( Generator polynomial $X^{11} + X^2 + 1$ ) Random code
PN15	$2^{15} - 1$ ( Generator polynomial $X^{15} + X + 1$ ) Random code
PN20	$2^{20} - 1$ ( Generator polynomial $X^{20} + X^{17} + 1$ ) Random code
PN23	$2^{23} - 1$ ( Generator polynomial $X^{23} + X^5 + 1$ ) Random code
Mark	All 1
Space	All 0
ALT	10..
DBL-ALT	0011..
1 in 4	1000..
1 in 8	10000000..
1 in 16	1000000000000000..
3 in 24	010001000000000000000100..

■ Flow control

If checked, RTS-CTS flow control is enabled. When this unit is DTE, the test pattern is sent only when CTS is active, and when this unit is DCE, the test pattern is sent only when RTS is active.

If unchecked, the test pattern will be sent regardless of the state of the RTS-CTS control lines.

## 5.2 Start and Stop

When you press [RUN], it starts to transmit the test pattern and compares the received data and the test pattern. Initially, until the initial pattern of the test pattern is received and synchronization is established, “SYNC Search” message is displayed. After synchronization is established, “Measuring” message is displayed and error rate measurement starts.

When using the RS-232C port, simultaneously with the start of test pattern transmission, when it is set to DTE the RTS and DTR signals are activated, and when it is set to DCE the CTS, DSR, and DCD signals are activated. When using the TTL port, only RTS is active.

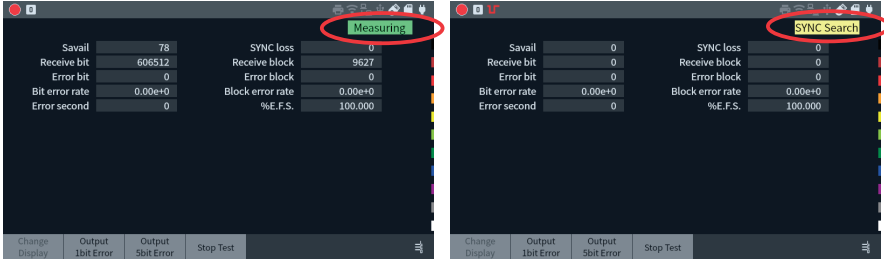

When the test mode is set to “Repetitiously”, the start time and measurement elapsed time of each measurement are displayed in “year/month/day/hour/minute”.

The following operations are available during measurement.

“Output 1bit Error” Inserts a 1-bit error in the test pattern. You can also insert it by pressing [0].

“Output 5bit Error” Inserts a 5-bit error in the test pattern. You can also insert it by pressing [1].

“Start/Stop Test” Press “Stop Test” to end the measurement of counting error rate while it keeps transmitting the test patterns. Press “Start Test” to start the new measurement.

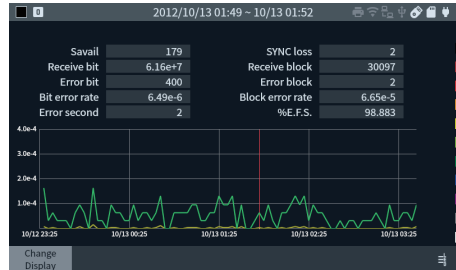

When you press [STOP], the test pattern transmission and error rate measurement will end. Depending on the test mode, the measurement will end automatically when the set conditions are met.

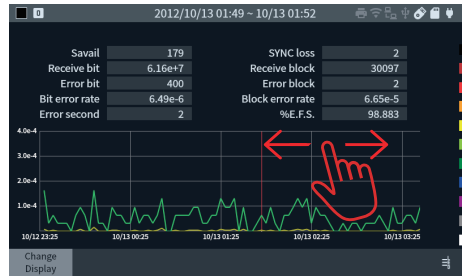

If “Repeat” is selected at “Test mode”, it displays measured data where the cursor is pointed at.

☰ Move the cursor by [◀],[▶] to change the data displayed. Swipe the graph to change the range of data.

## 5.3 Contents of the Line Quality Data

You can measure the communication error rate with parameters which comply with ITU-T Recommendation G.821.

Item	Contents	Range of measurement	Remark
Savail	Effective time since the first synchronization was established	0 ~ 9999999(sec)	1),2)
Receive bit	Number of received bits during synchronization establishment	0 ~ 9999999 ~ 9.99E9	1)
Error bit	Number of received bits during synchronization establishment	0 ~ 9999999 ~ 9.99E9	
Bit error rate	Bit error rate	0.00E-0 ~ 9.99E-9	
Sync loss	Number of loss of synchronization	0 ~ 9999	3)
Receive block	Number of received blocks during synchronization establishment	0 ~ 9999999 ~ 9.99E9	4)
Error block	Number of blocks with bit errors	0 ~ 9999999 ~ 9.99E9	4)
Block error rate	Block error rate	0.00E-0 ~ 9.99E-9	4)
Error second	Time when bit error was detected during Savail	0 ~ 9999	
%E.F.S.	Time when bit error was detected during Savail	0.000 ~ 100.000(%)	5)

- 1) Synchronization : When it receives normal data continuously for 32 bits establishment
- 2) Effective time : It counts the time when the bit error rate per second is less than 0.1% as the effective time.  
If the bit error rate of 0.1% or more continues for 10 seconds, that 10 seconds is excluded from the valid time. After the exclusion, if the bit error rate is less than 0.1% for 10 seconds, the 10 seconds are added and it restarts the counting.
- 3) Sync loss : When more than 200 error bits occur in 512 consecutive bits.
- 4) 1 block length : Number of bits for 1 cycle of test pattern.
- 5) %E.F.S :  $\frac{(\text{Savail}) - (\text{Error second})}{(\text{Savail})}$

# Chapter 6 Useful Functions

## 6.1 Trigger Function

The trigger function is a function that triggers a special measurement process (action) triggered by a specific condition (factor) such as the occurrence of a communication error during measurement operation or reception of specified data. By controlling the timer/count, it can measure the communication response time and count the number of occurrences of specific events. This is useful when analyzing the flow of communication under the specific interest.

- ☰ The trigger function is valid only in the online mode of the monitor function and MANUAL mode of the simulation function
- ☰ The condition of the trigger factor is also used as the execution condition of the statistical analysis function and the PROGRAM mode (of the simulation function).

Functions of trigger are different in Normal mode and High-speed mode.

### ■ Normal mode

[Factor]

Error	Communication error, break, multiprocessor bit on
Character	Communication data of up to 8 characters
Line state	Logic state of interface signal line and external trigger input
Time/Count	Timer/Counter value match
Idle time	Idle time exceeding the specified time

[Action]

Buzzer	Buzzer sound
Stop measurement	Stops the measurement/test (offset number until stop can be specified.)
Save data	Save data before and after the trigger to the storage device
Timer control	Start/stop/restart of the timer 0-3 for trigger
Counter control	Start/stop/restart of the counter 0-3 for trigger
Trigger control	Enables/disables/inverts the state of trigger condition
Transmit data	Transmits the specified character string (during manual simulation)
OT2 pulse output	Outputs low pulse for about 1msec. to "TRG OT2".

### ■ High-speed mode

[Factor]

TXD Character	TXD character: Character string in the TxD.
RXD Character	RXD character: Character string in the RxD.
Error	Error: Communication error .
TRG IN	Detecting level "0" in the external trigger input (TRG IN)

[Action]

Stop measurement	Stops the measurement/test (offset number until stop can be specified.)
OT2 pulse output	Outputs low pulse for about 1msec. to "TRG OT2".

## External trigger input/output

You can use an abnormal signal from an external device as a trigger input, or can detect the occurrence of a special factor on the communication line by this analyzer and notify it to an external measuring instrument such as an oscilloscope.

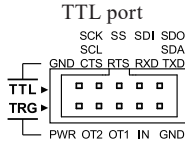

The TRG IN terminal can be specified as the line state condition of the trigger factor.

TRG OT1 terminal outputs L pulse for about 1 ms when all trigger factors are satisfied.

TRG OT2 terminal outputs L pulse for about 1 ms when OT2 operation is specified as a trigger factor.

☞ The trigger terminal is pulled up to 5V inside the analyzer.

☞ When a new trigger is generated while the trigger pulse is being output, it goes to HIGH level about 1 ms after the last trigger is generated.

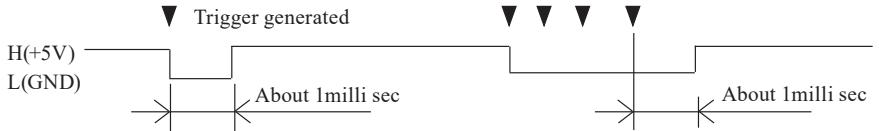

## Setting

Tap “Trigger” from top menu to set trigger conditions.

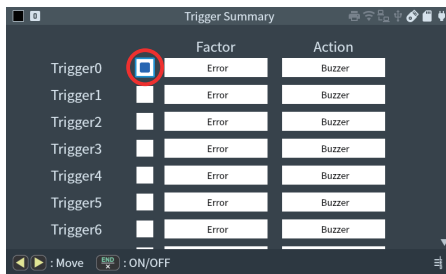

Mark on the check box to valid the target trigger. If you mark more than one, it will be OR condition.

Tap “Factor” or “Action” to change the conditions of trigger. For high-speed mode, trigger action has to be the same for all triggers.

For normal mode, tap “Timer/Counter settings” at the bottom of the screen to set the comparative value of the timer/counter used in the trigger function.

6.2 Timer/Counter Function

☞ You can also move to the setting screen of the factor/operation to be changed by selecting with [▲], [▼],[◀],[▶] and press [ENTER].

☞ When the factor of each trigger number is satisfied, the corresponding operation is executed. When multiple triggers are enabled, the triggers with smaller trigger numbers are judged in order.



## Trigger Factor

For normal mode, select a trigger factor for Trigger0 to Trigger7.

For high-speed mode, select a trigger factor from “TXD character”, “RXD character”, “error” and “TRG IN”. Other setting items cannot be set (grey out).

### □ Error

A specific condition such as error or break are treated as a trigger condition.

Errors which are not determined in the protocol of measurement target communication are not judged. BCC/FCS error is not judged if error check is not enabled in the basic communication condition settings.

When “Parity error/MP bit =’1” is valid, I2C acknowledge bit =’1” is also detected.

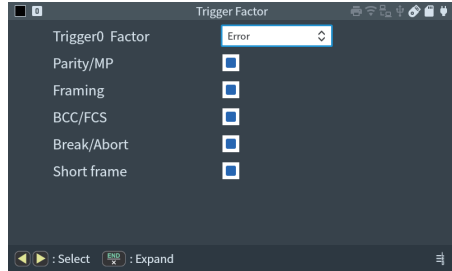

### □ Character (for Normal mode), TXD character/RXD character (for High-speed mode)

Specified communication data is treated as a trigger condition.

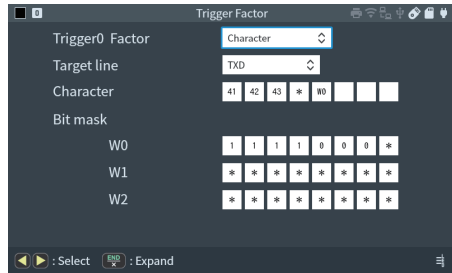

- Target line Select “TXD” or “RXD”. (only for Normal mode)
- Mode Select “Single” or “Sequential”. If selecting “Single”, Character D1 or D2 is treated as a trigger condition. If selecting “Sequential”, “Character D2 is generated after Character D1” is the trigger condition.
- Character Set the data string to be detected up to 8 characters. X (Don't Care) can be input by [END/X], and [ ] of bit mask W0 to 2 and SDLC/HDLC can be input by touching the corresponding mark at the lower right of the screen.
  - ☰ Bit masks W0 to 2 can be input by [SHIFT] + [0] to [2], and [ ] can be input by [SHIFT] + [F] too.
- Bit mask Set the bit string of bit mask W0 to 2 with [0], [1], and [END/X].
  - ☰ In the screen example, the trigger is activated when 5 bytes of 41h, 42h, 43h, arbitrary data, F0h or F1h are detected on the TXD side.

- Line state (for Normal mode), TRG IN (for High-speed mode)

For high-speed mode, low level of TRG IN is the trigger condition.

For normal mode, the conditions of the control line and TRG IN are treated as the trigger condition. Specify the signal logic to detect with 1(High), 0(Low), and X(don't care). The state judgment of 1 and 0 is as same as the line state display.

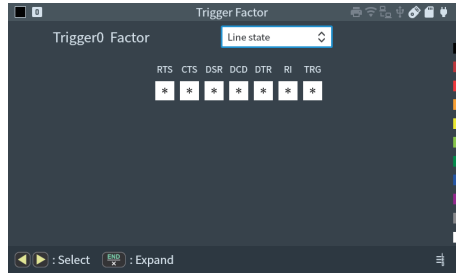

- ☰ With the AND condition of all signals, the condition is satisfied when the condition changes from mismatch to match.
- ☰ Control lines which are not on the selected measurement port are not judged.

- Time/Count

This setting is available only for Normal mode.

The value of the timer or counter is treated as the trigger condition.

There are 4 timers and 4 counters that can be used as triggers. Select which one to use. Also, input the value to be the condition at the Timer/Counter setting screen.

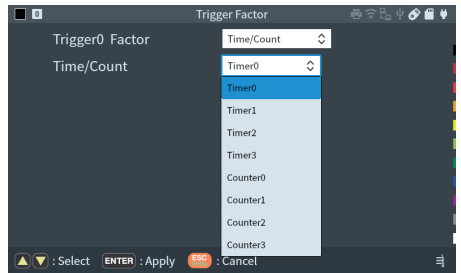

## 6.2 Timer/Counter Function

- Idle time

This setting is available only for Normal mode.

The trigger condition is met when the idle time being measured exceeds the set value.

- ☰ Idle time can be set in the range of 0 to 9999. The time unit is as same as the idle time unit specified at the Record control.

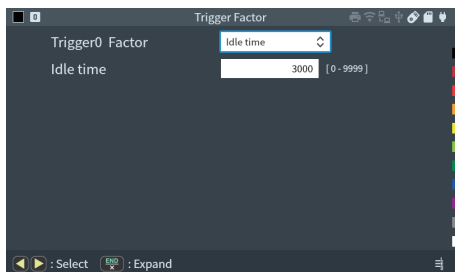



## Trigger Action

For normal mode, select any trigger actions for Trigger0 to Trigger7.

For high-speed mode, select a trigger action from “Stop measurement” or “OT2 pulse output” for Trigger0 to Trigger3 (trigger action cannot be set for each trigger).

### □ Buzzer

This setting is available only for normal mode.

The buzzer sounds for about 0.3 seconds when the corresponding trigger factors match.

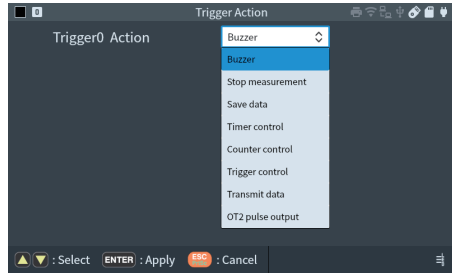

### □ Stop measurement

The measurement stops after the trigger factor matches.

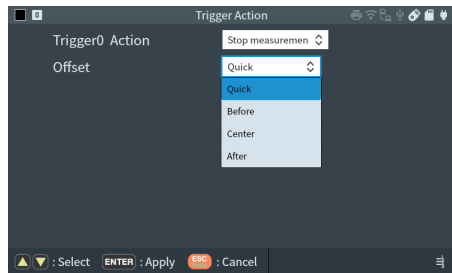

### ■ Offset

Set the conditions until the measurement stops after the trigger matches.

Quick : Immediately stops measurement

Before : Records more 64K data and then stops measurement

Center : Records half the capture buffer and then stops measurement

After : Stops the measurement keeping up to 64K data before trigger point

☰ “After” can record 100MB capture buffer size minus 64K data size after the trigger condition is met, so it can be used like a measurement start trigger.

## □ Save data

This setting is available only for Normal mode.

The measurement data before and after the trigger factor match is automatically saved in the storage device as a trigger save file (TGSAVEnn.DT - nn is a serial number from 0 to 99 in the order of saving). The amount to be saved at

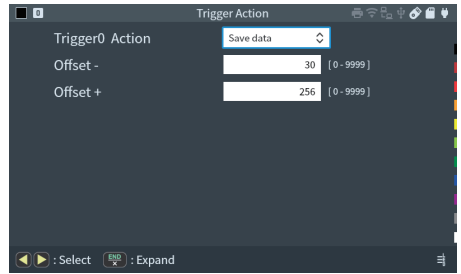

one time can be specified by the number of data (maximum 9999) before (offset-) / after (offset +) with the trigger point as the center.

Insert a storage device (SD card or USB flash drive) into this unit, and specify it at “Save Device” of the Auto save tab in “Record control” of [MENU].

- ☰ After the trigger factor is matched, the offset + minute data is saved in the file when it is captured. If you stop the measurement before capturing the data of that size, the file will not be saved.
- ☰ The next data save operation is ignored during the data save process.
- ☰ After TGSAVE99.DT, it will be overwritten by returning to TGSAVE00.DT. When the measurement is started again, it will be overwritten from TGSAVE00.DT.
- ☰ It does not write if the storage device is full.

After stopping the measurement, read the trigger save file into the capture memory and check it.

## 7.2 File Management Function

## □ Timer control

This setting is available only for Normal mode.

Controls the timer.

Specify the timer to be controlled (timer 0 to 3) and the control content (start, stop, restart from value 0).

 6.2 Timer/Counter Function

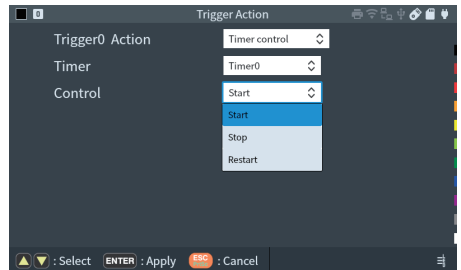

## □ Counter control

This setting is available only for Normal mode.

Controls the counter.

Specify the counter (counter 0 to 3) to be controlled and the control content (increment: +1, clear: clear value to 0).

 6.2 Timer/Counter Function

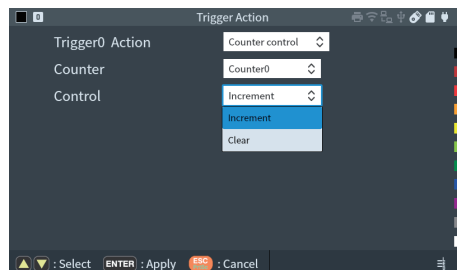

□ Trigger control

This setting is available only for normal mode.

Specify the trigger to be controlled (Trigger0 to Trigger7), disable/enable, change the status (reverse enable/disable from the current status) of it.

A trigger that is invalid at the start of measurement can be enabled by another trigger when it detects a specific condition during the measurement (sequential trigger).

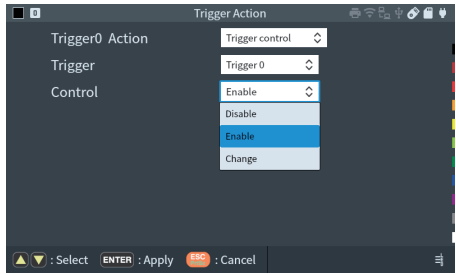

□ Transmit data

Following is the example of trigger setting in Normal mode.

Specified data is sent after the trigger factor matches. Specify the group number (group 0 to 9) and table number (table 0 to F) of the send data table in which the data you want to send is registered. When you select “Fixed data” in the group specification, you can select the transmission data which is preset in this unit.

For the “Response” set the time (0 to 99999 msec.) until the data transmission starts after the trigger factor matches.

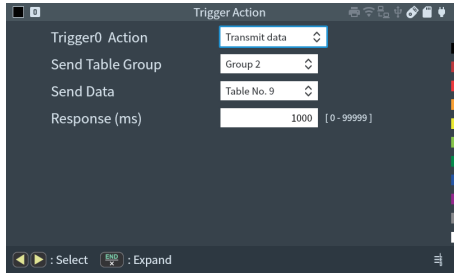

 4.1 Register Transmission Data

 This trigger action only works during simulation in MANUAL mode.

□ OT2 pulse output

A 1 milli sec Low pulse is output from TRG OT2 of the TTL port.

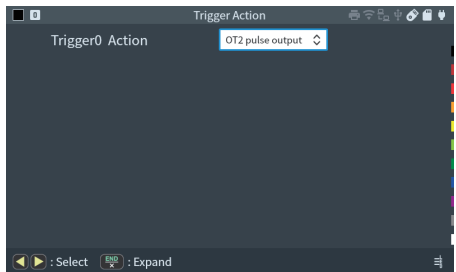



## Trigger Setting Example

Example of trigger setting (in normal mode):

- ◆ When a communication error occurs, the buzzer sounds and the number of error occurrences is counted

Enable trigger 0 and 1 and set Error as the factor and Buzzer and Counter control (increment) as the action.

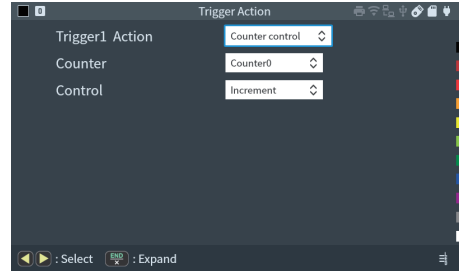
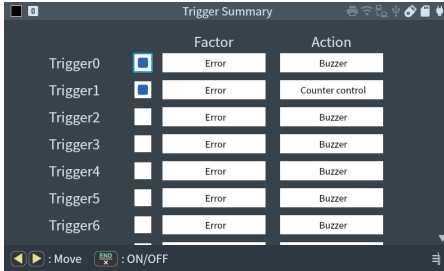

- ◆ Measurement stops when the receiving side detects character strings 31h, 32h, 33h after receiving the 41h, 42h, 43h

Enable only trigger 0. Set TXD data detection as the factor and Trigger control (enables trigger 1) as the action.

For the trigger 1, which is enabled from trigger 0, set RXD data detection as the factor and measurement stop as the action.

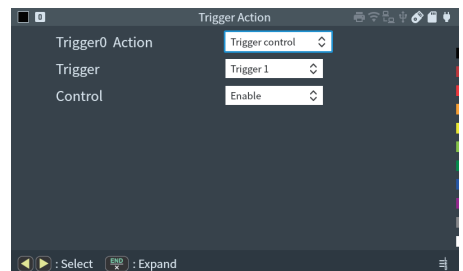
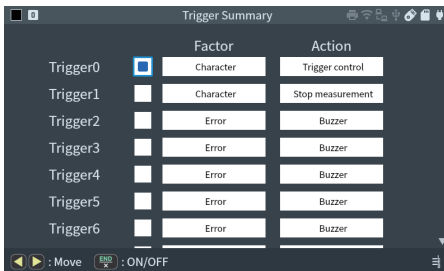

- ◆ Transmits the character string TEST (54h, 45h, 53h, 54h) when the external signal becomes L.

Enable trigger 0, set Line state (set 0 to external trigger input) as a factor and data transmission as the action.

Also, change the analyzer to the MANUAL mode (simulation) and register the character string TEST in the send data table.

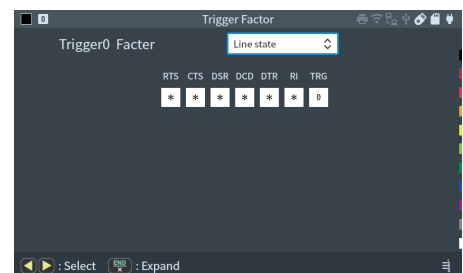
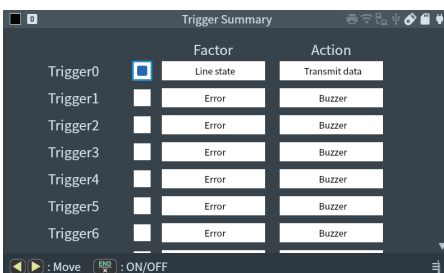

## 6.2 Timer/Counter Function

The timer/counter function is used together with the trigger function and program simulation function to measure the elapsed time from a specific condition and the number of occurrences of a specific factor.

Timers are used to measure the elapsed time after the occurrence of specific factor.

Counters are used to count the number of times which a specific factor occurs.

This setting is available only for normal mode.

### Setting

Display the top menu screen by [MENU] and select “Trigger”. Tap “Settings” for the Timer/Counter at the bottom of the settings section to display the settings screen.

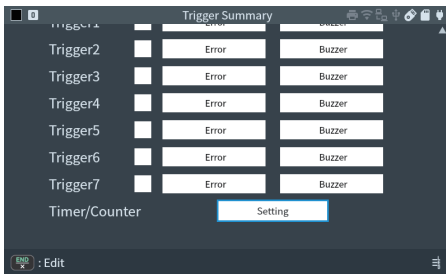

Set the comparison value (1 to 999999) of each timer/counter used for the trigger factor and the resolution (100msec, 10msec, 1msec) of each timer.

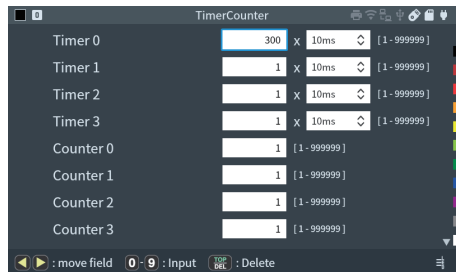

### Timer action

- 1) Cleared to 0 at the start of measurement. and the status changes to stop.
- 2) It starts, stops, or restarts (start after cleared to 0) according to the control information by the trigger function
- 3) When the set value (comparison value) of timer 0, 1 and the current value of timer 0, 1 match, the information is passed to the trigger function.
- 4) If the current value overflows, it continues counting from 0.
- 5) When you stop the measurement, the timer also stops at the point.



## Counter action

- 1) Cleared to 0 at the start of measurement.
- 2) It is incremented (+1) or cleared by the control information from the trigger function.
- 3) When the set value (comparison value) of counters 0 and 1 and the current value of counters 0 and 1 match, that information is passed to the trigger function.
- 4) If the current value overflows, it continues counting from 0.



## Display of timer/counter value

The timer/counter value can be checked by tapping “Change display” even during the measurement.

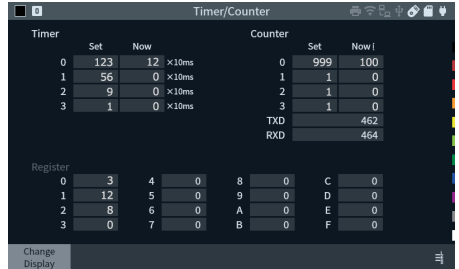

## 6.3 Timing Waveform Measurement Function

It is possible to measure the timing of change of the communication line with a time resolution of This function is to measure the timing of data changing as a logic analyzer through a communication line.

Timing of communication line is displayed by waveform with resolution of max. 5n sec.



## Setting

Tap “Wave Opt.” from top menu. When using the timing waveform measurement function, mark the check box of “Enable wave monitor” and then set the items.

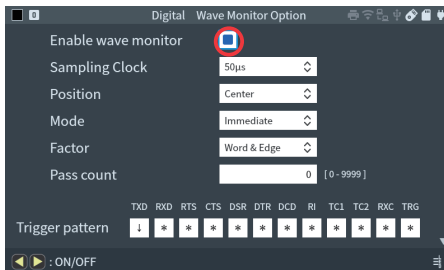

### ■ Sampling clock

Select the sampling clock cycle that is 5 to 10 times faster than the communication speed of the target device. For example, when analyzing 38400bps timing, select about 2µsec or 5 µsec.

■ Trigger position

Tap the item to select the trigger position of the waveform monitor. Set the trigger position in the waveform monitor sampling memory (for 4K sampling) depending on which part of the waveform measurement data -before or after the trigger- is prioritized.

- Before : Captures some data from the trigger point and then stops.
- Center : Stops at the point where before and after parts of the trigger have the same amount of data.
- After : Captures a lot of data from the trigger point and stops.

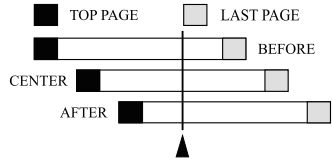

■ Trigger mode

- Immediat : Accept trigger action as soon as measurement starts.
- Full : Accept trigger action after measuring 4K of sampling data. (Even though the trigger condition is matched, trigger action is not executed.)

■ Trigger factor

- Word & edge : Logical status or edge of signal line will be the trigger condition.
- Online : Trigger number set in the “trigger condition” will be the trigger condition.

■ Pass count

Set the number of times (0 to 9999) to ignore the satisfied triggers. The trigger condition will be established without any interruption if setting “0”.

■ Trigger pattern

Sets the state of the signal line with which it automatically stops the waveform monitor measurement. The signals that can be set vary depending on the interface and the option board being used.

- [0] : 0
- [1] : 1
- [END/X] : X (Don't care)
- [SHIFT]+[0] : ↓(Falling edge)
- [SHIFT]+[1] : ↑(Rising edge)

- 📄 Be sure to set the edge (↑) (↓) to the trigger condition.
- 📄 TRG is the external trigger input TRG IN of the TTL port.

When RS-422/485 is selected



TXD	RXD	RTS	CTS	DSR	DTR	DCD	RI	TC1	TC2	RXC	TRG
↓	*	*	*	*	*	*	*	*	*	*	*

When TTL is selected

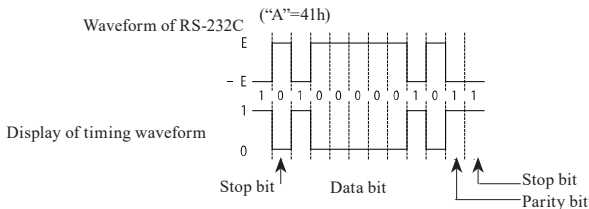
TXD	RXD	RTS	CTS	TRG
↓	*	*	*	*



## Control

- 1) Press [RUN] to start timing waveform measurement at the same time as the normal measurement function starts. “” Is displayed in the upper left of the screen.
- 2) When the waveform monitor trigger condition is met and the timing waveform sampling is completed, “” At the upper left of the screen disappears.
- 3) Press [STOP] to stop measurement.

## Display

Press the “Change display” at the bottom of the monitor data display screen for several times to switch to the timing waveform display screen.

### ■ Scroll the display

Swipe left or right to scroll to the part you want to see.



### ■ Zoom in/out of the display

Touch the magnification value to zoom in/out the display.

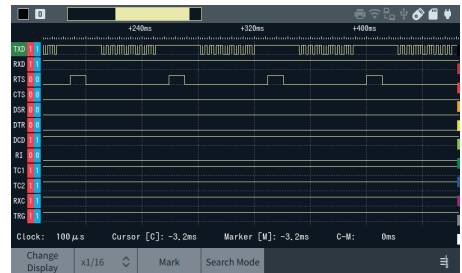
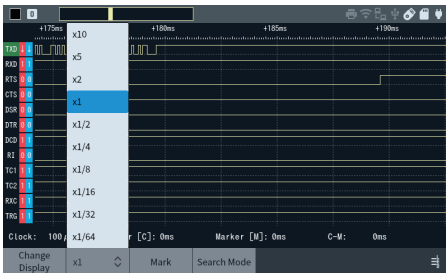

### ■ Time measurement between two points

On the screen, the blue dotted line is cursor C and the red dotted line is marker M.

First, move the cursor to the first signal position with [ ◀ ], [ ▶ ], and touch [ENTER] or “Mark” to move the marker to that position. Then, by [ ◀ ] and [ ▶ ] move the cursor to the signal position to where you want to measure the time from the marker position.

The time between the cursor and the marker is displayed at “C-M:” on the first line of the screen.

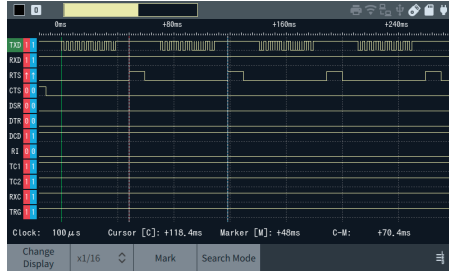

### ■ Search of signal status

When you touch “Search Mode” at the bottom of the screen, the status display (1, 0, ↓, ↑) at the cursor position on the left of the screen becomes x, and the area turns to be the input area of the signal status for the search target. Input here the state you want to search, and use [ ◀ ] and [ ▶ ] to search in that direction and move the cursor to the matching one. Touch “Search Mode” again to end the waveform search mode and [ ◀ ] and [ ▶ ] returns to cursor C movement.

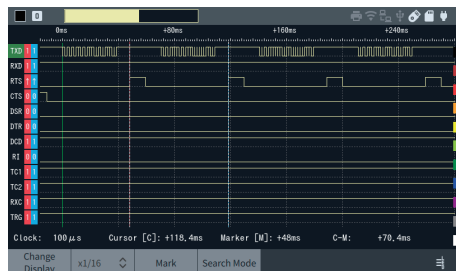
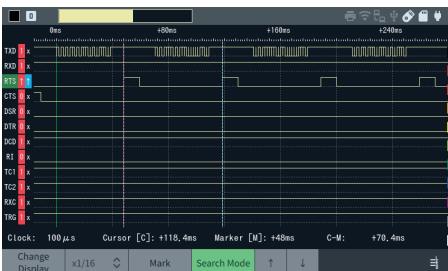

### ■ Change the display order of signal lines

Select the signal whose display order you want to change by [ ▲ ] and [ ▼ ]. Then you can use [SHIFT] + [ ▲ ] and [SHIFT] + [ ▼ ] to change the display order of the selected signals.

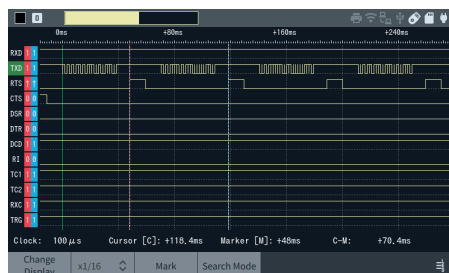

## 6.4 Auto Configuration Function

By using this function at online monitoring, you can automatically determine the communication conditions of the line to be monitored and start the measurement.



### How to use

Connect appropriate monitor cables to the target port and set the measurement port (“Interface”->“Measurement port”).

Measurement port cannot be set automatically.

Tap “Online” -> “Auto Config” from top menu to set auto configuration settings.

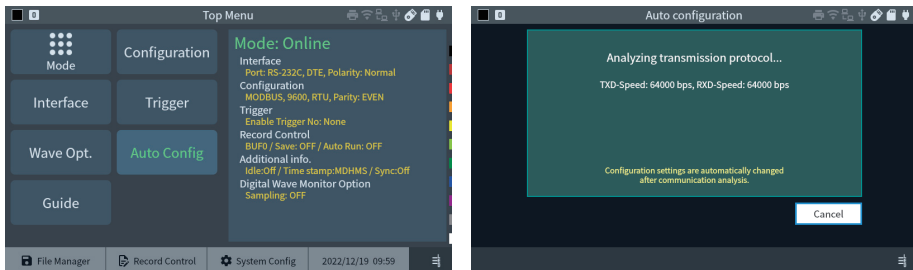

When the communication conditions are determined, the details will be displayed. A few seconds after that, the current communication condition settings are automatically changed to the determined communication conditions and it starts the measurement.

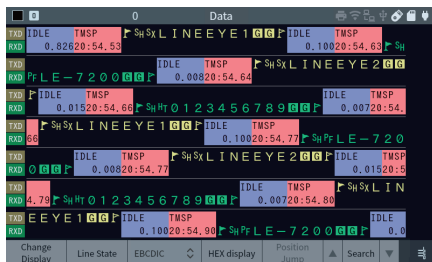

If you touch “Cancel” or press [STOP] or [ESC] before it starts measurement, the analysis processing of communication conditions will be stopped and the current communication condition settings will not be change.

The following conditions are required for the line to be measured in order to judge the communication conditions correctly.

- Communication speed is 1.544Mbps or less.
- Protocols are ASYNC, SYNC/BSC, or HDLC/SDLC.
- On the line communication data without error is flowing at a certain frequency.
- On the line communication data including bit patterns of '101' or '010' is flowing.



The auto configuration function of this analyzer is an auxiliary function for estimating the communication conditions. Please note that not all the conditions can be judged accurately.

# 6.5 Split Display

## ■ Split Display

Display data in two separated screen

Display saved data in BUF1 and BUF2 in the separated screen at the same time. It is useful to compare two data for finding a problem.

- 1) Save data in BUF1 or BUF2.

Select BUF1 or BUF2 from “Record control” to save data. Then start measuring data or load the measured data from memory device.

- 2) Press [SHIFT] + “Change Buffer” to measure data (or load data) in the other buffer.

- 3) Press [SHIFT] + “Split display” to display BUF1 and BUF2 data in the separated screen.

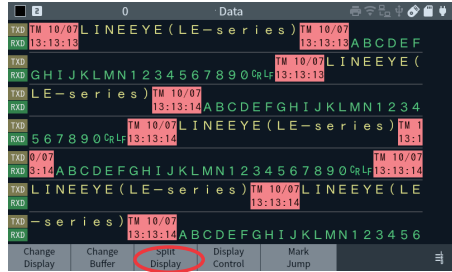

For normal operation, it only scrolls data on one side which is selected by an arrow. However, there is a function to scroll both side at the same time. Press “SYNC” and scroll data by [▲] [▼] keys.

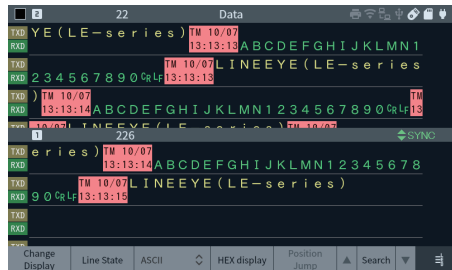
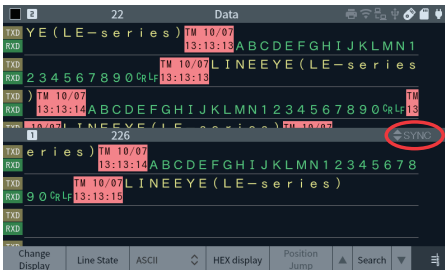

## 6.6 Translation Function



### User Translation Definition Function

- The outline of User Translation Definition Function

User Translation Definition Function is the function that translates the frame data of communication into the character strings or numbers according to the rule defined by user.

User defined translation function is the function that translates the frame data into the character strings or numbers according to the rule defined by user.

The translated contents are displayed at Field1 to Field4. To display “User translation” display, press [Change display] some times. (“User translation” function has to be selected.)

Timestamp	Line	Content	Field 1	Field 2	Field 3	Field 4
20:54.53	TXD	pat1	0	51669		
20:54.63	RXD	read	F1			
20:54.64	TXD	pat2		50645		
20:54.66	RXD	write				
20:54.66	TXD	pat1		51669		
20:54.77	RXD	read				
20:54.77	TXD	pat2		50645		
20:54.79	RXD	write				
20:54.80	TXD	pat1		51669		
20:54.90	RXD	read				
20:54.91	TXD	pat2		50645		
20:54.92	RXD	write				
20:54.93	TXD	pat1		51669		
20:55.03	RXD	read				
20:55.04	TXD	pat2		50645		

- ☞ For ASYNC, SYNC/BSC, and BURST, measured data must be with the time stamps to use this function. Set the “Time stamp” in the Record control in advance.
- ☞ Flag in SDLC/HDLC, Block check code(BCC) and Frame check sequence(FCS) set in the “Configuration”, Break[B] and Abort[A] are not included to the frame data. In the protocol of I2C, Re-start sequence is not included. In the protocol of PPP or IrDA, Escape sequence is decoded.

Items	Meaning
TXD line	Indicates that the frame is on the TXD side.
RXD line	Indicates that the frame is on the RXD side.
Time	Shows the time when the frame was received.*1
Field 1 to 4	Indicates the content defined by user ( 1 to 4 )

\*1: It appears when “Time stamp” setting is other than Off in the “Record control”.

■ Procedure of setting User's defined translation

1. Tap “Display Control”.

- User Translate  
Mark on the check box of “User Translate”.
- Field1-4 Name  
“Field1-4 Name” with 6 characters.

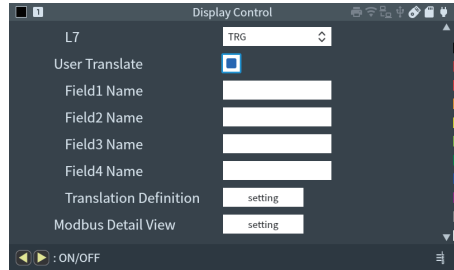

Display Control setting

2. Tap “setting” on “Translation Definition”.

The settings of User's defined translation are listed in this area, so you can select the No. which you want to edit from this list.

“User Translation Definition” can be made up to 16 sets (No. 00 to 15). On the data display screen, the frames are checked along with the condition from No. 00 to 15.

No.	Field1				Field2				Field3				Field4			
	1	2	3	4	1	2	3	4	1	2	3	4	1	2	3	4
00					06	*	*		*	*			*	*		
01					08				*	*			*	*		
02					02				*	*	*	*	*	*	*	*
03					02				*	*			*	*		
04					03				*	*	*	*	*	*	*	*
05					03				*	*			*	*		
06					04				*	*	*	*	*	*	*	*
07					04				*	*			*	*		
08																

“User Translation Definition Summary” screen

If the frames are corresponding to more two definitions, the definition of low number is displayed.

All fields(Field1 to Field4) of the frame not corresponding to any translating definitions are empty.

“Display Change”      Change the area of “Field” whether “1, 2, 3, 4” (for the object of translation) or “String” (for translation characters). (The grey line means “invalid” and blue line means “in decimal”)

“Copy mode”            Tap it to become the copy mode (light in green).

“Copy”                    Copy the translation definition. (Available only in Copy mode)

“Paste”                    Paste the data that was copied. (Available only in Copy mode)

[SHIFT]+[A]              Make Field1 to Field4 of translation definition enable.

[SHIFT]+[D]              Make Field1 to Field4 of translation definition disable.

3. Select the No. by moving the cursor with [▲][▼], and press [Enter]. Or tap the item to edit in the translation definition display.

Set the condition on which the measured frame is translated and displayed in the raw of Field1 to Field4.

In the data display screen, the frame is translated only when it meets Field1 to Field4 all.

When the definition is changed, the display will be changed according to it.

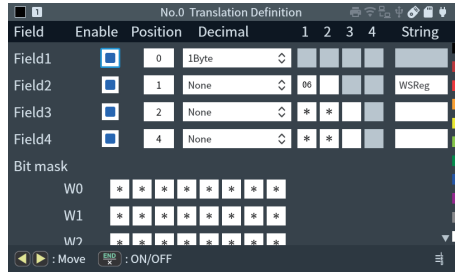

“Translation Definition” screen

Press [ESC] to go back to “User Translation Definition Summary” display.

- Check box  
Only the fields which are marked (valid) are used for translation. Invalid filed cannot be edited.
- Position  
Set position(byte) of data from top of the frame to translate.(from 0 to 60)  
If more two “Field”'s start bits are the same, the “Field” must be set to the same value or “\*”’(Don't care.) or same Bit mask(W0 to W2). Or the frames cannot be translated and displayed according to the definition.  
The flag of SDLC/HDLC is not the object to be translated.

- Decimal  
Select how to display the translated data in decimal in “Field”.  
“None” : Frame data is displayed in characters. (not in decimal)  
“1Byte” : 1-byte data from the “Position” is displayed in decimal.  
“Little endian” : 2-byte data from the “Position” is displayed in decimal from lowest bit.  
“Big endian” : 2-byte data from the “Position” is displayed in decimal from highest bit.  
When something other than “None” is selected, “1 to 4” and “String” are invalid and it is not translated to characters.

- 1 ~ 4  
Set target data to be translated into characters. The data of the size set in this term from the point of “Position” will be translated and the MAX size is 4 bytes in HEX. The setting starts from 1. Then “\*”’(Don't care ) and “W0” to “W2” can be set.  
If nothing is set in this term, the “Field” is invalid.  
[SHIFT]+[0] : Input the bitmask “W0”.  
[SHIFT]+[1] : Input the bitmask “W1”.  
[SHIFT]+[2] : Input the bitmask “W2”.  
[End/X] : Input “\*”’(Don't care ).

- String  
Set how to translate data “1” to “4” into characters.  
you can set up to 6 characters. When nothing is set, the data is displayed in HEX.
- Bit Mask  
Set bit mask(Bit7 to 0) of Data1 to 4 to specify in bit unit.  
You can set “Bitmask” per “No”. And There are 3 kinds of “BitMask” (“W0”, “W1”, “W2”) in one “No”.  
“BitMask” changes in order to Bit7 to Bit0 from the left.  
[0] : Press [0] to input “0”.  
[1] : Press [1] to input “1”.  
[End/X] : Press [End/X] to input “\*” (the mask).

<Example>

When the analyzer measures the frame [01h,02h,03h,04h,05h,06h,07h,08h,09h,10h],  
in Field1 it displays 1 byte in decimal from 1st byte from the top of the frame,  
in Field2 it displays 1 byte(03h) as “Read” from 2nd byte from the top of the frame,  
in Field3 it displays 2 byte(04h, 05h) as “Status” from 3rd byte from the top of the frame,  
in Field4 it displays 2 byte(if there is some of 2 bytes data ) in HEX from 5th  
byte from the top of the frame.

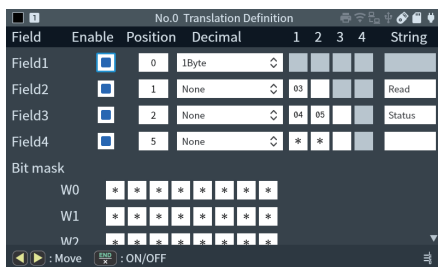

## 6.7 Auto Save Function

By using the auto save function, the contents of the capture memory (captured data) can be automatically saved for a long time as a measurement log file (auto save file) of a specified size in a storage device such as an SD card. As you can check the auto-save file which was automatically saved while a rare communication failure occurred with the file management function and the attached PC link software, it is useful to analyze the communication failure of unknown cause.

< Estimated recording time by the storage device capacity >

Speed	Continuous recording time reference <sup>*1</sup>		
	Main memory only	64GB USB memory <sup>*2*3</sup>	500GB SSD <sup>*2*3</sup>
9600bps	Approximately 60 hours	Approximately 152 days	Approximately 1203 days
115.2Kbps	Approximately 5 hours	Approximately 312 hours	Approximately 40 days
1Mbps	Approximately 36 minutes	Approximately 40 hours	Approximately 13 days

\*1 When 1 kilobyte data is repeatedly transmitted by full duplex with intervals of 1m second idle time for each. Both transmission and reception data consume 4 byte of memory for each capture.

\*2 Connect to USB host port. USB3.0 are recommended.

\*3 Up to 2TB of storage (formatted in FAT32) is available.

Does not guarantee the operation of all USB memory and USB connected SSDs.



### Setting

Display the top menu screen by [MENU], touch “Record control”, and then touch the “Auto save” tab to display the setting screen.



2.2.4 Record Control ■ Auto save function



- If you set “Restart” or “Max-Stop”, all existing auto save files will be deleted at the start of measurement.
- When saving the measurement log for a long time with the auto save function, set the main unit capture memory to the ring buffer. Also, make sure that the trigger condition that stops the measurement is not set.



2.2.4 Record Control ■ Capture Buffer



6.1 Trigger Function

# Chapter 7 Save and Load of the Data

## 7.1 Storage device

An SD/SDHC card or USB flash drive can be used as a storage device, and measurement data and setting data can be saved to it.

- Optional SDHC cards (SD-8GX, SD-16GX, SD-32GX, sold by LINEEYE) are available. You can use a USB flash drive, but we do not guarantee the operation of all USB flash drives.
- Storage devices formatted with exFAT or NTFS cannot be used. You need to reformat it with FAT32 before use, but it may not be possible on Windows depending on the version and capacity. Use the tools provided by each storage device manufacturer.

The measurement data automatically saved in the storage device using the auto save function etc. is saved in the storage device specified in “Save Device” of the auto save tab of “Record Control” in [MENU].

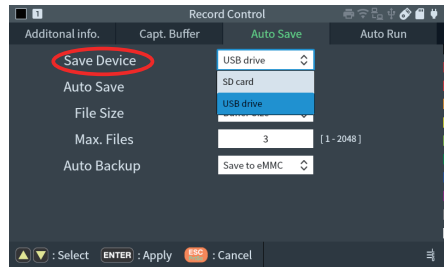

If you select either “USB drive” or “SD card” for “Screen shot save to” in the Display/Power tab of “System Config” in [MENU], the screenshot will be saved in the external storage device. When both storage devices are connected, it will be saved to the storage device specified in this setting.

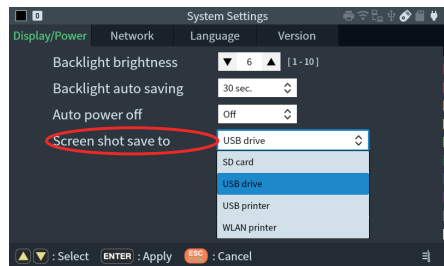

## 7.2 File Management Function

You can save, read, and delete the measured data and setting data in the storage device as a file that can be read/written by a PC.

Tap File Manager on the top menu screen to move to the connected storage directory screen or printer management screen.

Tap “File Manager” or “Device Change” at the bottom of each screen to switch to each screen.

File management operations are performed on the directory screen.

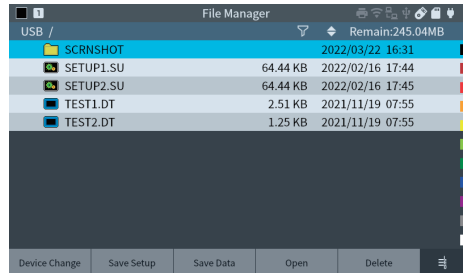
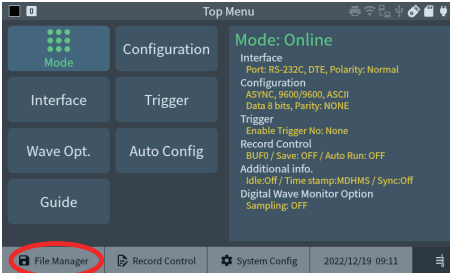

You can scroll and display the files on the directory screen by swiping the screen or by pressing [ ▼ ] or [ ▲ ]. If both the SD/SDHC card and the USB memory are inserted, tap “Device Change” at the bottom of the screen to switch to the directory screen of the storage device to be operated.

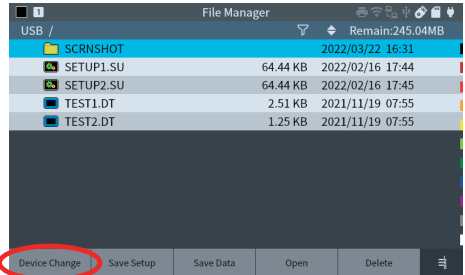
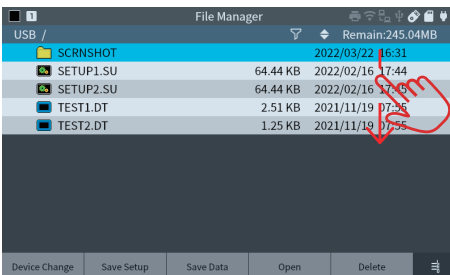

### Save data

When you tap “Save data” on the directory screen, the full key image and text input window will be displayed on the screen.

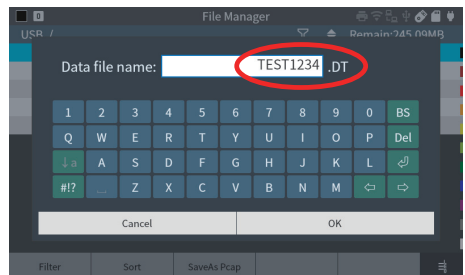

Touch the keyboard or the full key on the screen to enter the file name and tap “OK” or press [ENTER] to save all measurement data in the capture memory and return to the directory screen. The measurement data file extension DT is automatically added.

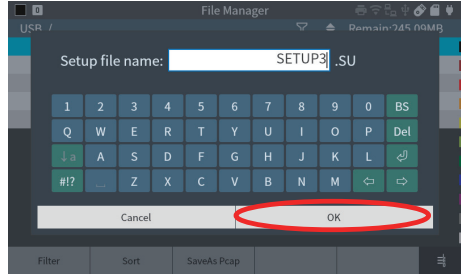

## Save setup

When you touch “Save setup” on the directory screen, the full key image and the text input window will be displayed on the screen. Touch the full key on the screen to enter the file name, and then touch “OK” or press [ENTER] to save all setting data of the top menu and return to the directory screen. The file extension SU of the setting data is automatically added.



-  You can enter the symbols that can be used as the file name by tapping “#!?”.
-  The “System settings” display and Power and network settings are not saved in the setting data file.
-  The “System Settings” display, power setting, and network setting are not saved in the settings data file.

	Never remove the storage device while it is accessing files
---	---

## File sorting and display filters

### ◆ Sort

Touch “◆” on the directory screen and specify the file name, extension, size, or modification date to display them in ascending or descending order.

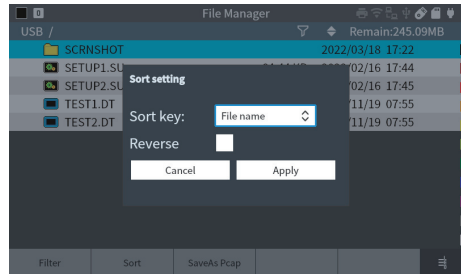
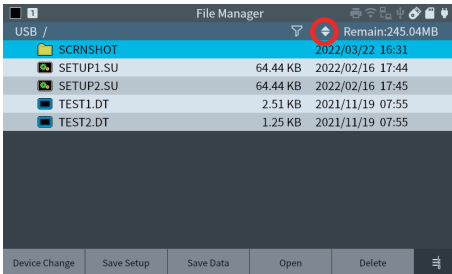

-  The sort display is maintained until you specify it again with “◆” or reboot the device.

## ◆ Filter

Tap “” on the directory screen to display only the specified file type.

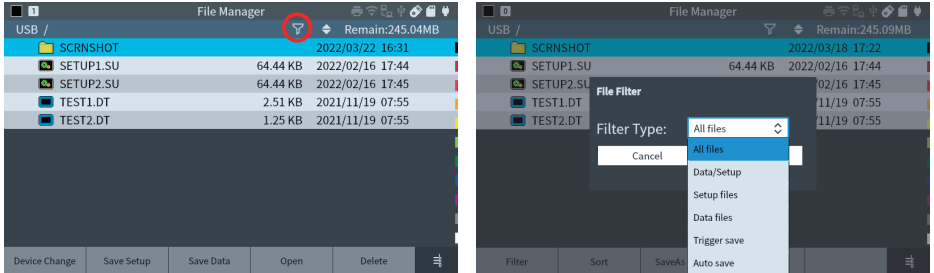

The following file types can be specified for the filter display.

All files

Analyzer measurement data file and setting data file

Analyzer setting data file

Analyzer measurement data file

File automatically saved by the trigger function (TGSAVEnn.DT)



File automatically saved by the auto save function (#nnnnnnn.DT)

When you “Apply” the filter, only the files with the specified conditions will be displayed.

The filter icon turns red while the filter is being applied.

 The filter display will be canceled when you move to another screen.

## Load file

On the directory screen, double-tap the file, or tap the file you want to load or select the file with  or  and then tap “Load File” to load the data of the file. When the setting data file is read, the measurement conditions are uploaded and the menu screen is displayed. When the measurement data file is read, the original measurement data is cleared and the data display screen of the measurement data read from the file is displayed.

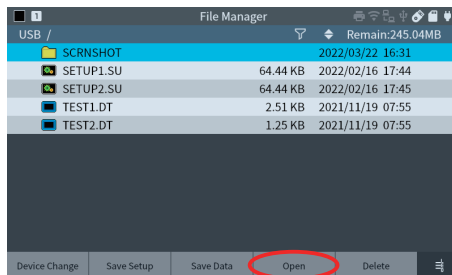



 Files with extensions other than DT, SU, PNG, TXT and CSV cannot be loaded.

◆ Loading the file in subdirectory

On the directory screen, double-tap the subdirectory that contains the file you want to read (hereinafter, the folder), or tap it with [▼] or [▲] and then tap “Open” to display the files in that folder.

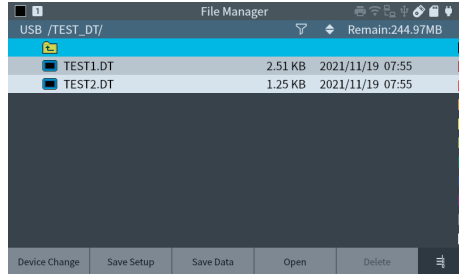
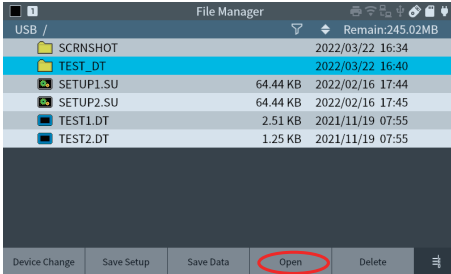
Select “” and touch “Open” to move to the upper directory.



 You cannot create folders or move files to folders on the analyzer. This kind of operation needs to be performed on a PC.

## Delete a file

◆ Delete a file

Tap the file to be deleted on the directory screen or select it with [▼] or [▲], tap “Delete”, and tap “Yes” (or [ENTER]) in the deletion confirmation window to delete the file.

To stop the deletion tap “No”.

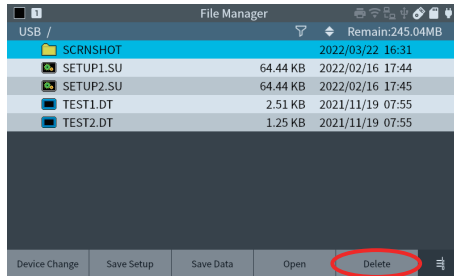

◆ Batch deletion of multiple files

To delete multiple files at once, long-tap (touch for about 1 second) any file on the directory screen to display the file selection display.

Tap the file you want to delete (or select it with [▼] or [▲] and press [ENTER]), and a checkmark will be added to the file. To deselect it tap the selected file again. Tap “Delete” and then tap “Yes” (or [ENTER]) in the deletion confirmation window to delete the selected file.

To cancel the deletion, tap “No”.

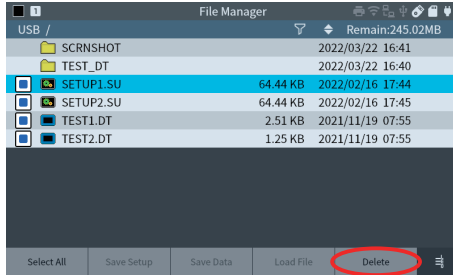

◆ Delete all the files

In the file selection display, tap “Select all” to select all the files displayed in the directory screen. Tap “Delete” and then “Yes” in the confirmation window to delete all the files. When you want to delete all the specified files, for example, only the files automatically saved by the auto save function (#nnnnnnn.DT), you can do so by using the filter display of the files.

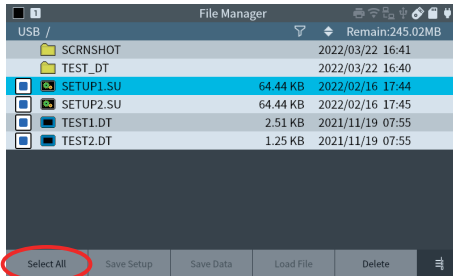

📄 Long tap again or press [ESC] to return to the original display and cancel the selection.

◆ Export Data

If you tap [SHIFT]+“Export” on the directory screen, the file export dialog will be displayed.

The item to be selected differ depending on the measurement data.

■ Export Type

Select the file output format.

txt : Output measurement data in txt format.

csv : Output TREND, BERT measurement data in csv format.

- When the measurement data is TREND or BERT

- Top Position

Displays the top position of the current graph screen.

- Resolution

Displays the resolution of the measurement data.

- Number of Data

Select how many to output from the current top position.

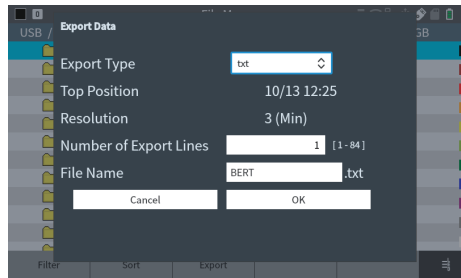

- When the measurement data is monitor data other than DELAY, TREND, BERT

- Top Position

Displays the top position of the current graph screen.

- Export Type

Specifies the output format.

Select data when you want to output the data display and select frame when you want to output the frame display.

The output “txt” will be the current screen display.

For example, when outputting with the hexadecimal display is turned on on the data screen it will be output in hexadecimal.

If “packet” is selected on the frame display, a list of packets will be output.

- Number of Export Pages

Select how many pages to convert from the current position. (66 lines per one page.)

- File Name

Enter a file name. When selected, a file name input dialog is displayed.

Tap “OK” or press [ENTER] to save the file to your storage device.

- Monitor data format

Information for one character of measurement data is printed in two lines in HEX (hexadecimal) and characters using a printing space for four characters.

If the character code is undefined or “△” (space code), nothing is displayed on the character line.

If there is no data, “-” is displayed in the HEX line.

Time information and line states of control lines are displayed as follows.

Idle time [IDLE]	Timestamp [ TMSP ]	Line state	H “11”
[0020]	[051735]		L “00”
			H → L “10”
			L → H “01”



## ◆ Frame

```

#=[LE-8500X]====[2023-03-10 13:09:53]=#
# Model      : LE-8500X      *
# Version    : 1.03.07      *
# Extension  : SB-R2T51     *
# Serial No. : 99999999    *
# Start time : 2023-03-10 13:09:05 *
# Stop time  : 2023-03-10 13:09:16 *
#-----#
# MONITOR DATA (X.25 FRAME)
# PROTOCOL : HDLC          *
# TX-SPEED : 9600         *
# RX-SPEED : 9600         *
# CODE     : ASCI1        *
#          : FCS          *
#          : FCS16       *
# FORMAT   : NRZ          *
#          : CLOCK       *
#          : AR           *
# TX-ADDR  : *            *
# RX-ADDR  : *            *
# IDLE TM  : OFF         *
#          : TM STAMP: MDMHS *
#-----#
-----TM-----AD-TYPE-----NS-PF-NR-F0-----DATA-----
RXD:0310130908 54 INFO 4 0 2 G 452051554943482042524F574E20464F58
TXD:0310130910 02 INFO 0 1 1 G 3132333435363738394142434445464748
TXD:0310130911 30 RR 1 1 1 G 3233343536373839414243444546474849
TXD:0310130912 02 INFO 0 1 1 G 3132333435363738394142434445464748
RXD:0310130912 02 INFO 0 1 1 G 3132333435363738394142434445464748
TXD:0310130913 30 RR 1 1 1 G 3233343536373839414243444546474849
RXD:0310130913 30 RR 1 1 1 G 3233343536373839414243444546474849
TXD:0310130913 02 INFO 0 1 1 G 3132333435363738394142434445464748
RXD:0310130913 02 INFO 0 1 1 G 3132333435363738394142434445464748
TXD:0310130914 54 INFO 4 0 2 G 452051554943482042524F574E20464F58
TXD:0310130914 30 RR 1 1 1 G 3233343536373839414243444546474849
TXD:0310130914 02 INFO 0 1 1 G 3132333435363738394142434445464748
RXD:0310130915 02 INFO 0 1 1 G 3132333435363738394142434445464748
TXD:0310130915 30 RR 1 1 1 G 3233343536373839414243444546474849
TXD:0310130915 30 RR 1 1 1 G 3233343536373839414243444546474849
RXD:0310130915 54 INFO 4 0 2 G 452051554943482042524F574E20464F58
RXD:0310130916 02 INFO 0 1 1 G 3132333435363738394142434445464748
TXD:0310130916 02 INFO 0 1 1 G 3132333435363738394142434445464748
TXD:0310130916 54 INFO 4 0 2 G 452051554943482042524F574E20464F58

```

## ◆ BERT

```

#=[LE-8500X]====[2023-02-15 14:25:10]=#
# Model      : LE-8500X      *
# Version    : 1.03.00      *
# Extension  : SB-R2T51     *
# Serial No. : 99999999    *
# Start time : 2023-02-03 12:25:24 *
# Stop time  : 2023-02-03 17:04:08 *
#-----#
# BERT RESULTS
# PROTOCOL : ASYNC        *
# S-SPEED  : 921.6k      *
# R-SPEED  : 921.6k      *
# CHAR BIT : 8          *
# STOP BIT : 1          *
#-----#
DATE-TIME  LOSS  R-BIT  E-BIT  BIT-ERR  E-BLK  BLK-ER  E-SEC  ME.F.S
02/03 12:25      0 6.16e+7 200 3.25e+6      1 3.32e-5      1 99.441
02/03 12:28      4 6.15e+7 800 1.30e+5      5 1.60e-4      4 97.778
02/03 12:31      2 6.15e+7 400 6.50e+6      2 6.60e-5      2 98.863
02/03 12:34      1 6.19e+7 200 3.25e+6      1 3.33e-5      1 99.441
02/03 12:37      2 6.16e+7 400 6.50e+6      3 9.98e-5      2 98.889
02/03 12:40      1 6.19e+7 200 3.25e+6      2 6.62e-5      1 99.441
02/03 12:43      1 6.19e+7 200 3.25e+6      1 3.32e-5      1 99.441
02/03 12:46      1 6.15e+7 200 3.25e+6      1 3.33e-5      1 99.441
02/03 12:49      0 6.15e+7 0 0.00e+0      0 0.00e+0      0 100.000
02/03 12:52      2 6.19e+7 400 6.49e+6      2 6.63e-5      2 98.863
02/03 12:55      3 6.17e+7 600 9.73e+6      4 1.33e-4      3 98.324
02/03 12:58      2 6.17e+7 400 6.48e+6      2 6.63e-5      2 98.863
02/03 13:01      1 6.19e+7 200 3.24e+6      1 3.31e-5      1 99.441
02/03 13:04      1 6.17e+7 200 3.24e+6      1 3.32e-5      1 99.441
02/03 13:07      2 6.15e+7 401 6.52e+6      4 1.33e-4      3 98.324
02/03 13:10      0 6.16e+7 0 0.00e+0      0 0.00e+0      0 100.000
02/03 13:13      3 6.19e+7 600 9.75e+6      4 1.33e-4      3 98.324
02/03 13:16      0 6.15e+7 0 0.00e+0      0 0.00e+0      0 100.000
02/03 13:19      2 6.16e+7 400 6.50e+6      2 6.63e-5      2 98.863
02/03 13:22      0 6.16e+7 0 0.00e+0      0 0.00e+0      0 100.000

```



## Error message

If an error message is displayed when accessing the storage device, take appropriate action.

When the data could not be read, the following cases can be considered - the storage device is not recognizable, the capture buffer is write-protected, the data is corrupted, or the data was saved with an optional board other than the one currently in use.

When the data could not be saved, the following cases can be considered - the storage device is not recognized, there is no free space in the saving destination, or the saving destination is writeprotected.

# Chapter 8 Utility

## 8.1 PC Link Function

By using the optional PC link software LE-PC800X, you can perform remote monitoring and convert measurement data into text files on your PC. Connect this unit to your PC via LAN, USB, or Wi-Fi.

### ■ USB connection

Connect the PC and the USB device port of this analyzer with a USB cable.

### ■ LAN connection

Connect the LAN environment of the PC and the LAN port of the analyzer with a LAN cable. Configure the wired LAN connection in the system settings of this analyzer.

### ■ For Wi-Fi connection

At the system setting of the analyzer select the station mode or the access point mode and set the SSID and password required for Wi-Fi connection.

📄 Check with your network administrator about the network settings.

### ■ Installing the PC Link Software LE-PC800X Lite Version

The “LE-PC800X Lite Version,” which has some limited functionality, can be downloaded free of charge from the LINEEYE website. Unzip the downloaded file and run setup.exe in the folder to install.

→ See the online help of the PC link software for how to use it.

[Example of Key emulation Screen]

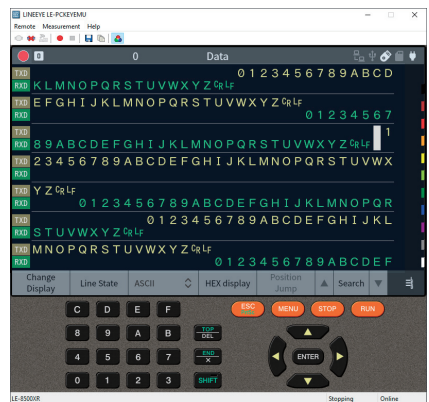
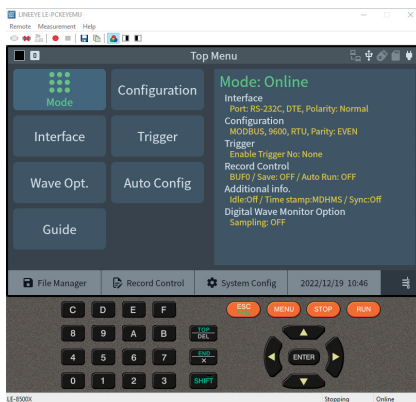

\* To use only the key emulation function, key emulation software (LE-PCKEYEMU) is recorded in the attached CD.

[Example of Remote Monitor Screen]

Remote01 - LINEEYE LE-PC800X

File Remote Measurement Tool Help

Data monitor (Normal view) Data monitor (Translated view) Timer/Counter Wave monitor

ASCII

```

TXD IDLE TM 10/24 SH! TSHV q%001904 IDLE TM 10/24 TXD
RXD 5.56517:37:44 ETRKHTBSTEST_DATAE IDLE TM 10/24 TXD
TXD IDLE TM 10/24 NUSXSYX0123456789ABCDEFGHIJKLMNPOQRSTU TXD
RXD ETRKHTBSTEST_DATAE IDLE TM 10/24 TXD
TXD VWXYZZFF IDLE TM 10/24 IDLE TM 10/24 SH! TSHV q%0 TXD
RXD 1.15317:37:47 ETRKHTBSTEST_DATAE IDLE TM 10/24 TXD
TXD 01905 IDLE TM 10/24 ETRKHTBSTEST_DATAE IDLE TM 10/24 NUSXSYX TXD
RXD 0.89017:37:51 ETRKHTBSTEST_DATAE IDLE TM 10/24 TXD
TXD 0123456789ABCDEFGHIJKLMNPOQRSTUVWXYZZFF IDLE TM 10/24 TXD
RXD 2.56217:37:49 ETRKHTBSTEST_DATAE IDLE TM 10/24 TXD
TXD 24 IDLE TM 10/24 SH! TSHV q%001907 IDLE TM 10/24 TXD
RXD 0.42017:37:55 ETRKHTBSTEST_DATAE IDLE TM 10/24 TXD
TXD IDLE TM 10/24 SH! TSHV q%001908 IDLE TM 10/24 TXD
RXD ETRKHTBSTEST_DATAE IDLE TM 10/24 TXD
TXD 10/24 IDLE TM 10/24 SH! TSHV q%001909 IDLE TM 10/24 TXD
RXD 1.537:59 ETRKHTBSTEST_DATAE IDLE TM 10/24 TXD
TXD 24 ETRKHTBSTEST_DATAE IDLE TM 10/24 SH! TSHV q%001904 IDLE TM 10/24 TXD
RXD 1.46617:38:00 ETRKHTBSTEST_DATAE IDLE TM 10/24 TXD
TXD 10/24 NUSXSYX0123456789ABCDEFGHIJKLMNPOQRSTUVWXYZZFF IDLE TM 10/24 TXD
RXD 1.06017:38:02 ETRKHTBSTEST_DATAE IDLE TM 10/24 TXD
TXD 0017:38:03 ETRKHTBSTEST_DATAE IDLE TM 10/24 TXD
TXD IDLE TM 10/24 SH! TSHV q%001905 IDLE TM 10/24 TXD
RXD 1.11717:38:04 ETRKHTBSTEST_DATAE IDLE TM 10/24 TXD
TXD IDLE TM 10/24 IDLE TM 10/24 SH! TSHV q%001906 IDLE TM 10/24 TXD
RXD 0.92317:38:05 ETRKHTBSTEST_DATAE IDLE TM 10/24 TXD
TXD TAE ETRKHTBSTEST_DATAE IDLE TM 10/24 NUSXSYX0123456 TXD
RXD 0.79617:38:06 ETRKHTBSTEST_DATAE IDLE TM 10/24 TXD
TXD 789ABCDEFGHIJKLMNPOQRSTUVWXYZZFF IDLE TM 10/24 TXD
RXD 0.81017:38:07 ETRKHTBSTEST_DATAE IDLE TM 10/24 TXD
TXD EST_DATAE IDLE TM 10/24 SH! TSHV q%001907 IDLE TM 10/24 TXD
RXD 0.89217:38:08 ETRKHTBSTEST_DATAE IDLE TM 10/24 TXD
TXD q%001908 IDLE TM 10/24 IDLE TM 10/24 SH! TSHV q%001909 IDLE TM 10/24 TXD
RXD 1.51617:38:10 ETRKHTBSTEST_DATAE IDLE TM 10/24 TXD
RXD 2.40117:38:12 ETRKHTBSTEST_DATAE IDLE TM 10/24 TXD
    
```

0 [Received data> : 0] Stopping Online LE-8500X + SB-R2T51

[Example of text conversion]

```

x=====([2022-09-31 19:21:51])=x
* Model : LE-8500X *
* Version : 1.00 *
* Extension : Standard *
* Serial No. : 99999999 *
* Start time : 2022-09-31 17:08:17 *
* Stop time : 2022-09-31 17:18:11 *
-----x
* MONITOR DATA *
* PROTOCOL: HDLC *
* S-SPEED : 1M R-SPEED : 1M *
* CODE : ASCII FCS : FCS16 *
* FORMAT : NRZ CLOCK : ST1 *
* S-ADDR : * R-ADDR : * *
* IDLE TM : 1ms TM STAMP: MDHMS *
* PRINT CODE : ASCII *
x=====x

SD: [ IDLE ] [ T 0331 ] [ 7E00020202303132333435383738394142434445464748494A4B4C4D4E4F505152535455565758595A5B5C5D5E5F60616263646566676869707172737475767778798081828384858687888990919293949596979899AABBCCDDEEFFFF ] [ 0122 ] [ 170817 ] "NUSXSYX 0 1 2 3 4 5 6 7 8 9 A B C D E F G H I J K L M N O P Q R S T U V W X Y Z { } | " [ 0 ]
RD:

SD: LE [ T 0331 ] ----- [ IDLE ] [ IDLE ] [ T 0331 ] [ 7E01215401567125303031353434A1077E ] [ 19 ] [ 170817 ] "ETAKHTBSTEST_DATA { }" [ 0200 ] [ 0015 ] [ 170817 ] "SH! TSHV q % 0 0 1 5 4 4 { }" [ 0 ]
RD: 7E04060906544563545F44415441EEEE8B057E

SD: LE [ T 0331 ] ----- [ IDLE ] [ T 0331 ] [ 7E01024C494E45456945B0507E ] [ 00 ] [ 170817 ] "NUSXSYX 0 1 2 3 4 5 6 7 8 9 A B C D E F G H I J K L M I" [ 0210 ] [ 170818 ] "NUSXSYX 0 1 2 3 4 5 6 7 8 9 A B C D E F G H I J K L M I"
RD: 7E01024C494E45456945B0507E

SD: 4F505152535455565758595A5B5C5D5E5F606162636465666768697071727374757677787980818283848586876888990919293949596979899AABBCCDDEEFFFF
    
```

## 8.2 Capture data files while measuring



### “LE file downloader”

“LE file downloader” captures the communication log files saved in the storage device using the auto save function and send them to the PC via LAN or Wi-Fi. This tool is useful to capture the communication log files which has the time stamp around the time when a communication failure occurred, and to analyze the target data using the PC link software.

- “LE file downloader” transfers only the measurement data files with the name of “#nnnnnnn.DT” (n is a sequential number starting from “0”) saved by the auto save function.



### How to use

- Download and unzip the “LE file downloader (lefiledownload.exe)” of ver.1.04 or later from LINEEYE website to an appropriate folder on the PC. No installation required.
- Make sure that the analyzer and PC are connected LAN or Wi-Fi.



### 2.2.4 System Config

- Execute the auto save function.
- Double-click the “lefiledownload.exe” and enter the IP address and port number of the analyzer, and click “Connect”.
- The communication log files saved by the auto save function are listed on the window. Click “Update list” to display the latest list.



### 2.2.3 Record Control

- Click [ ... ] to specify the saving destination, and select the communication log file to be imported to the PC referring to the time stamp of the file.

The communication log file in saving process by the auto save function cannot be downloaded.

- Click “Download” to start transferring to the specified save destination via LAN or Wi-Fi. It may take 1 minutes or more to transfer a 16Mbyte file, depending on the load of the analyzer and the radio wave condition.
- Read the downloaded communication log files to the PC link software (LE-PC800X) and analyze it.

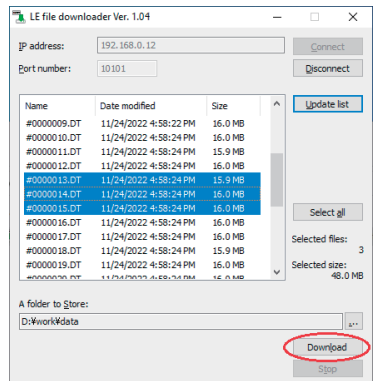
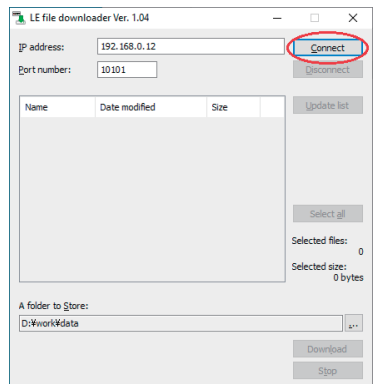

## 8.3 PC Remote Control Library

---

The libraries for Windows are available to make a user application software which remotely controls the analyzer from a PC. The library can be downloaded from LINEEYE website.

- For Windows

Windows 11/10/8.1, VC++6.0 and VC++.NET are supported.

Above operating environment is confirmed by our environment and we do not guarantee a correct operation.

# Chapter 9 Printout Function

Measurement data can be printed out on a printer.

You can also print a hard copy, which outputs the image displayed on the screen to the printer as it is. Tap “File Manager” at the bottom of the top menu screen to move to the “File Manager” that displays the directory list of the connected storage or the “Printer Management” that configures printout settings.

Every time you tap “Device Change” or “File Manager” at the bottom of each screen, it switches between “File Manager” of the connected storage and “Printer Management”.

## 9.1 How to Connect to a Printer

Connection with the dedicated printer SM4-31W (option) is via USB or wireless LAN.

- When using the printer via USB

Connect the USB port of this analyzer and the printer with a USB cable.

You can check the status of the USB connection by checking the status of the USB connection on the “Printer Management”.

- When using the printer via wireless LAN

Connect this machine and printer to the same access point, etc., or set the printer's Wi-Fi setting to the Direct mode to connect this analyzer.

Set the IP address and port number set for the printer on the “Printer Management”.

For the printer's Wi-Fi settings, refer to the printer's manual, etc.

## 9.2 Hard Copy of Screen Display

Select USB printer or WLAN printer for Screenshot save to in Display/Power tab of System Config. Press [SHIFT]+[ESC] on the screen you want to output and then the printing will start.

Hard copy print example

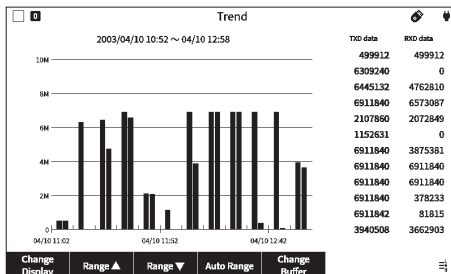

## 9.3 Printout of Measurement Data

When you press “Print” on the printer management screen, a dialog will appear.

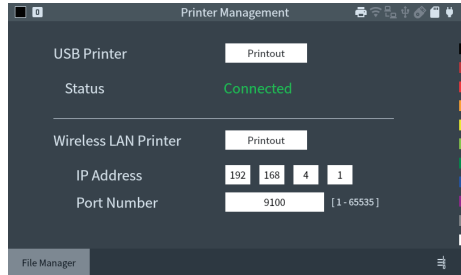

Specify Number of Pages, Number of Lines, etc. in the dialog that appears and press OK. Then the printing will start.

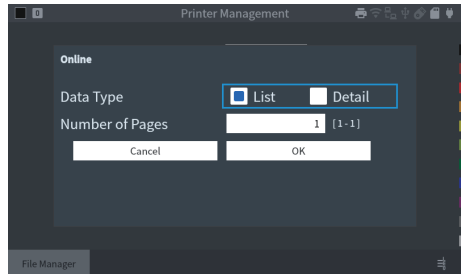

The options in the dialog are the same as those described in the section on Export Data in 9.2 File Management Function.

However, the maximum output is limited to approximately 300 lines for data part.

\* Only measurement data that supports text output can be printed.

# Chapter 10 Documents

## 10.1 Calculation of the Block Check

The block check is executed as follows.



### For ASYNC, SYNC, and BSC

- Start calculation : When any characters set in “Begin code” is received, calculation will start with the next character.
- End calculation : When any characters set in “End code” or “ITB code” is received, calculation will finish.
- BCC check : When the End code is received after the Begin code has been received, data next to the End code will be checked as the BCC. Also, the ITB code is applied to the End code.



### For HDLC and SDLC

- Calculation start : After the flag synchronization is established, it starts the calculation from the first received data.
- Calculation end : It calculates up to the character immediately before the sync release flag.
- FCS judgment : The character immediately before the sync release flag is checked as FCS.

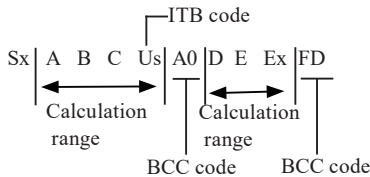
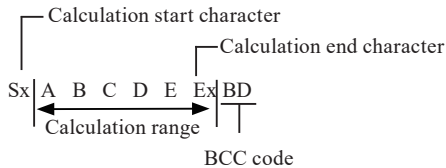



- If you select “ON” for the “Transparent” setting, the analyzer will enter the transparent mode and calculate BCC as follows.
- The character set in the “DLE mode” is handled as the Data Link Escape code.
- The received frame that starts with DLE + calculation start code has the calculation range up to DLE + calculation end code, and the calculation end code without DLE is treated as a normal character.
- DLE is excluded from BCC calculation. However, if two DLEs continue, the second DLE is treated as a normal character and is therefore subject to BCC calculation.
- Synchronization code without DLE is treated as a normal character, and synchronization code with DLE is excluded from the calculation.
- The block of the calculation starting with the calculation start code without DLE is the same as that when “Transparent” is set to “OFF”.

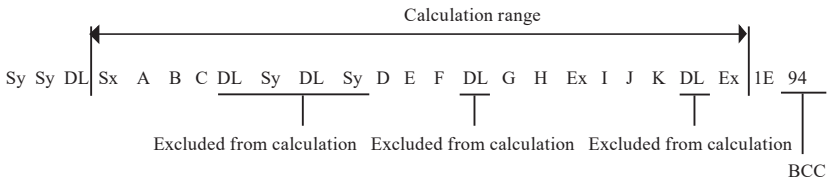

■ Reference

- LRC code  
 LRC O :horizontal parity odd  
 LRC E  
 (usually 'LRC E' is used.)
- CRC generator polynomial  
 CRC-6 : $X^6 + X^5 + 1$   
 CRC-12 : $X^{12} + X^{11} + X^3 + X^2 + 1$   
 CRC-16 : $X^{16} + X^{15} + X^2 + 1$   
 CRC-ITU-T : $X^{16} + X^{12} + X^5 + 1$
- FCS generator polynomial  
 FCS-16 : $X^{16} + X^{12} + X^5 + 1$   
 FCS-32 : $X^{32} + X^{26} + X^{23} + X^{22} + X^{16} + X^{12} + X^{11} + X^{10} + X^8 + X^7 + X^5 + X^4 + X^2 + X + 1$   
 (All 1 initial)

## 10.2 Send/Receive Clock

When sending/receiving data in synchronization with an external clock, setting of the transmission clock and the receiving clock varies according to the setting of DTE/DCE as shown below. Therefore, the synchronous clock for the specifications of the communicating device must be selected with “Clock” setting, to execute monitor, simulation, or BERT functions. (Excepting ASYNC mode)

Generally, it becomes following by the transmission clock of DTE.

◆ In the case of “ST1”

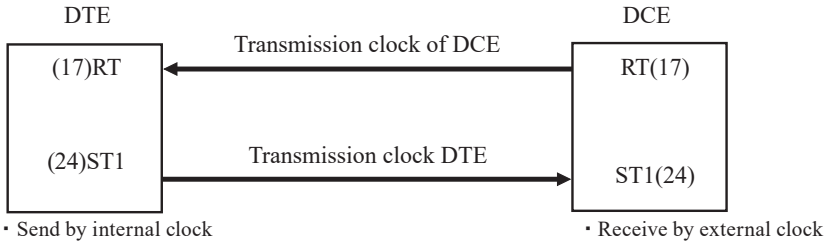

In the case of “ST2”

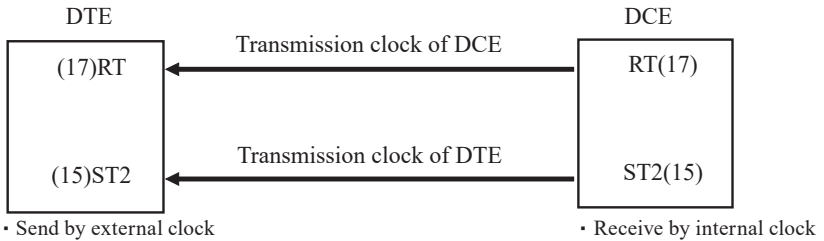

Signal Name

RT = RXC

ST1 = TXC1

ST2 = TXC2

◆ In the case of “RT”

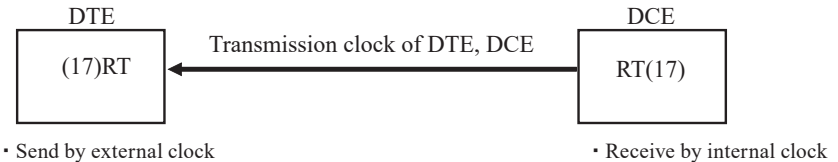

◆ “AR” (Auto Regulation )

“AR” refers to a data receiving process using the internal clock by detecting a change in the received data in implementing topology synchronization in accordance to the change. This process requires the channel speed to be the same as that of the transmitting/receiving equipment.

■ Change the selection of clock and port

This analyzer allows selection of the synchronous clock with “Clock” to enable monitoring/ simulating with any clock setting. This analyzer also allows to change specifications of the port with “DTE/DCE mode” in order to simulate the device whichever of DTE and DCE by an attached cable.

1) When monitoring

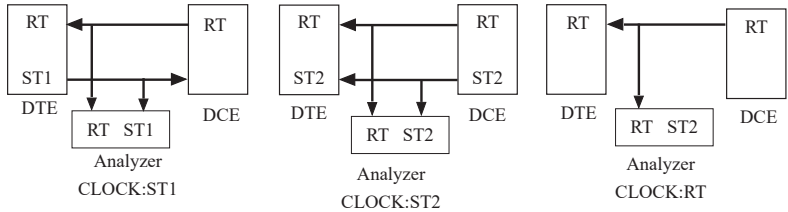

Signal Name

RT = RXC

ST1 = TXC1

ST2 = TXC2

2) When performing a simulation with DCE (this unit is in DTE mode).

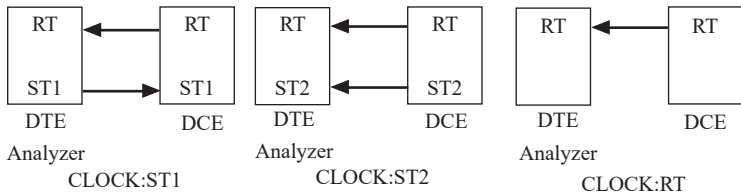

3) When performing a simulation with DTE (this unit is in DCE mode).

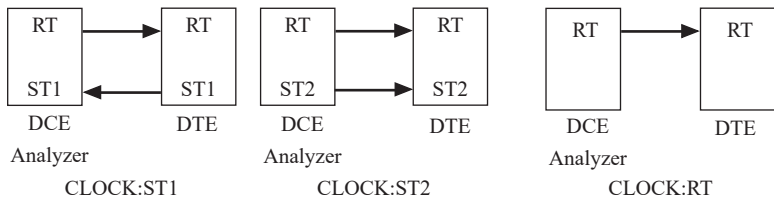

## 10.3 About the Frame

---

The definition of 1 frame is as shown in the table below for each protocol.

Protocol	Definition of 1 frame
ASYNC	Data string until the idle time longer than one set at “Frame end time” in the configuration is detected or the data set at “Frame end code” is received.
SYNC/BSC	Data string from the synchronization establishment character set at “Sync code” in the configuration to the synchronization release character set at “Reset code”.
HDLC/SDLC	Data string from start flag to end flag.
ASYNC-PPP	Data string from flag character (7Eh) to flag character (7Eh).
MODBUS	In RTU mode, the data string until detecting the non-communication time of silent interval (3.5 characters) or more. In ASCII mode, Data string from start code (3Ah) to end code (0Dh, 0Ah).
I2C/I3C	Data sequence from start sequence detection to stop sequence detection.
SPI	The period during which the SS signal is active, or in high-speed mode the data sequence received before detecting that the clock has not changed for more than the configured “frame end time”
PROFIBUS	Data string from the start delimiter until the specified number of data is received or until an idle time of 10.5 bits or more is detected
Burst	Data string until an idle time set at “Frame end time” in the configuration or more is detected.

## 10.4 Data Code Chart

- Blank box (not defined code) appeared in the code table is displayed in HEX.
- For JIS7, EBCD and Baudot codes, SHIFT IN and SHIFT OUT displays are alternated in accordance to SI/SO data.
- Display is started with the SHIFT IN display.
- When SI is received first, the SHIFT IN is displayed until the next SO is received.
- When SO is received first, the SHIFT OUT is displayed until the next SI is received.

### ■ ASCII

	0	1	2	3	4	5	6	7
0	NU	DL	△	0	@	P	`	p
1	SH	D1	!	1	A	Q	a	q
2	SX	D2	”	2	B	R	b	r
3	EX	D3	#	3	C	S	c	s
4	ET	D4	\$	4	D	T	d	t
5	EQ	NK	%	5	E	U	e	u
6	AK	SY	&	6	F	V	f	v
7	BL	EB	'	7	G	W	g	w
8	BS	CN	(	8	H	X	h	x
9	HT	EM	)	9	I	Y	i	y
A	LF	SB	*	:	J	Z	j	z
B	VT	EC	+	;	K	[	k	{
C	FF	FS	,	<	L	\	l	
D	CR	GS	-	=	M	]	m	}
E	SO	RS	.	>	N	^	n	~
F	SI	US	/	?	O	_	o	DT

### ■ EBCDIC

	0	1	2	3	4	5	6	7	8	9	A	B	C	D	E	F
0	NU	DL	DS		△	&	-						{	}	\	0
1	SH	D1	SS				/		a	j	~		A	J		1
2	SX	D2	FS	SY					b	k	s		B	K	S	2
3	EX	D3	WS	IR					c	l	t		C	L	T	3
4	PF	RE	BP	PN					d	m	u		D	M	U	4
5	HT	NL	LF	TN					e	n	v		E	N	V	5
6	LC	BS	EB	NS					f	o	w		F	O	W	6
7	DT	PC	EC	ET					g	p	x		G	P	X	7
8	GE	CN	SA	S2					h	q	y		H	Q	Y	8
9	SI	EM	SE	IT					i	r	z		I	R	Z	9
A	RT	US	SM	RF	¢	!		:								
B	VT	C1	CP	C3	.	\$	,	#								
C	FF	IF	MA	D4	<	*	%	@								
D	CR	IG	EQ	NK	(	)	_	'								
E	SO	RS	AK		+	;	>	=								
F	SI	IB	BL	SB		~	?	^								

■ JIS7(7)

For Roman characters

SHIFT IN

	0	1	2	3	4	5	6	7
0	NU	DL	△	0	@	P	`	p
1	SH	D1	!	1	A	Q	a	q
2	SX	D2	”	2	B	R	b	r
3	EX	D3	#	3	C	S	c	s
4	ET	D4	\$	4	D	T	d	t
5	EQ	NK	%	5	E	U	e	u
6	AK	SY	&	6	F	V	f	v
7	BL	EB	'	7	G	W	g	w
8	BS	CN	(	8	H	X	h	x
9	HT	EM	)	9	I	Y	i	y
A	LF	SB	*	:	J	Z	j	z
B	VT	EC	+	;	K	[	k	{
C	FF	FS	,	<	L	\	l	
D	CR	GS	-	=	M	]	m	}
E	SO	RS	.	>	N	^	n	~
F	SI	US	/	?	O	_	o	DT

- When SI is received first, Roman characters are displayed until the next SO is received.

For Kana characters

SHIFT OUT

	0	1	2	3	4	5
0	NU	DL	△	-	タ	ミ
1	SH	D1	。	ア	チ	ム
2	SX	D2	「	イ	ツ	メ
3	EX	D3	」	ウ	テ	モ
4	ET	D4	,	エ	ト	ヤ
5	EQ	NK	・	オ	ナ	ユ
6	AK	SY	ヲ	カ	ニ	ヨ
7	BL	EB	ア	キ	ヌ	ラ
8	BS	CN	イ	ク	ネ	リ
9	HT	EM	ウ	ケ	ノ	ル
A	LF	SB	エ	コ	ハ	レ
B	VT	EC	オ	サ	ヒ	ロ
C	FF	FS	ヤ	シ	フ	ワ
D	CR	GS	ユ	ス	ヘ	ン
E	SO	RS	ヨ	セ	ホ	°
F	SI	US	ツ	ソ	マ	°

- When SO is received first, Kana (Japanese characters) are displayed until the next SI is received.

■ JIS(8)

	0	1	2	3	4	5	6	7	8	9	A	B	C	D	E	F
0	NU	DL	△	0	@	P	`	p				-	タ	ミ		
1	SH	D1	!	1	A	Q	a	q			。	ア	チ	ム		
2	SX	D2	”	2	B	R	b	r			「	イ	ツ	メ		
3	EX	D3	#	3	C	S	c	s			」	ウ	テ	モ		
4	ET	D4	\$	4	D	T	d	t			,	エ	ト	ヤ		
5	EQ	NK	%	5	E	U	e	u			・	オ	ナ	ユ		
6	AK	SY	&	6	F	V	f	v			ヲ	カ	ニ	ヨ		
7	BL	EB	'	7	G	W	g	w			ア	キ	ヌ	ラ		
8	BS	CN	(	8	H	X	h	x			イ	ク	ネ	リ		
9	HT	EM	)	9	I	Y	i	y			ウ	ケ	ノ	ル		
A	LF	SB	*	:	J	Z	j	z			エ	コ	ハ	レ		
B	VT	EC	+	;	K	[	k	{			オ	サ	ヒ	ロ		
C	FF	FS	,	<	L	\	l				ヤ	シ	フ	ワ		
D	CR	GS	-	=	M	]	m	}			ユ	ス	ヘ	ン		
E	SO	RS	.	>	N	^	n	~			ヨ	セ	ホ	°		
F	SI	US	/	?	O	_	o	DT			ツ	ソ	マ	°		

■ EBCDIK

	0	1	2	3	4	5	6	7	8	9	A	B	C	D	E	F
0	NU	DL	DS		△	&	-			ソ			{	}	\	0
1	SH	D1	SS				/		ア	タ	~		A	J		1
2	SX	D2	FS	SY					イ	チ	へ		B	K	S	2
3	EX	D3	WS	IR					ウ	ツ	ホ		C	L	T	3
4	PF	RE	BP	PN					エ	テ	マ		D	M	U	4
5	HT	NL	LF	TN					オ	ト	ミ		E	N	V	5
6	LC	BS	EB	NS					カ	ナ	ム		F	O	W	6
7	DT	PC	EC	ET					キ	ニ	メ		G	P	X	7
8	GE	CN	SA	S2					ク	ヌ	モ		H	Q	Y	8
9	SI	EM	SE	IT					ケ	ネ	ヤ		I	R	Z	9
A	RT	US	SM	RF	¢	!		:	コ	ノ	ユ	レ				
B	VT	C1	CP	C3	.	¥	,	#				ロ				
C	FF	IF	MA	D4	<	*	%	@	サ		ヨ	ワ				
D	CR	IG	EQ	NK	(	)	_	'	シ	ハ	ラ	ン				
E	SO	RS	AK		+	;	>	=	ス	ヒ	リ	ゝ				
F	SI	IB	BL	SB		¬	?	”	セ	フ	ル	°				

■ Baudot

SHIFT IN

	0	1
0	NU	T
1	E	Z
2	LF	L
3	A	W
4	△	H
5	S	Y
6	I	P
7	U	Q
8	CR	O
9	D	B
A	R	G
B	J	SO
C	N	M
D	F	X
E	C	V
F	K	SI

SHIFT OUT

	0	1
0	NU	5
1	3	”
2	LF	)
3	-	2
4	△	#
5	'	6
6	8	0
7	7	1
8	CR	9
9	\$	?
A	4	&
B	BL	SO
C	,	.
D	!	/
E	:	;
F	(	SI

■ EBCD

SHIFT IN

	0	1	2	3
0	△	2	1	3
1	-	k	j	l
2	@	s	/	t
3	&	b	a	c
4	8	0	9	#
5	q	VT	r	\$
6	y	FF	z	,
7	h		i	.
8	4	6	5	7
9	m	o	n	p
A	u	w	v	x
B	d	f	e	g
C		SO	RS	ET
D		BS	CR	SY
E		EB	LF	EC
F		SI	HT	DT

SHIFT OUT

	0	1	2	3
0	△	<	=	;
1	_	K	J	L
2		S	?	T
3	+	B	A	C
4	*	)	(	”
5	Q	VT	R	!
6	Y	FF	Z	,
7	H		I	.
8	:	,	%	>
9	M	O	N	P
A	U	W	V	X
B	D	F	E	G
C		SO	RS	ET
D		BS	CR	SY
E		EB	LF	EC
F		SI	HT	DT

■ Transcode

	0	1	2	3
0	SH	&	_	0
1	A	J	/	1
2	B	K	S	2
3	C	L	T	3
4	D	M	U	4
5	E	N	V	5
6	F	O	W	6
7	G	P	X	7
8	H	Q	Y	8
9	I	R	Z	9
A	SX	△	EC	SY
B	.	\$	,	#
C	<	*	%	@
D	BL	US	EQ	NK
E	SB	ET	EX	EM
F	EB	DL	HT	DT

■ IPARS

	0	1	2	3
0			@	\$
1	1	/	J	A
2	2	S	K	B
3	3	T	L	C
4	4	U	M	D
5	5	V	N	E
6	6	W	O	F
7	7	X	P	G
8	8	Y	Q	H
9	9	Z	R	I
A	0	-	:	?
B	*	#	<	.
C	CR	△	+	%
D	EI	EC	EU	EP
E	=	[	)	S2
F		,	(	S1

## 10.5 Translation Display Specification



### BSC Translation display

Only the control characters used in the BSC communication are displayed.

Transmission control character	Display	EBCDIC (EBCDIK)	ASCII (JIS)	Transcode
SOH	SH	01	01	00
STX	SX	02	02	0A
ETB	EB	26	17	0F
ETX	EX	03	03	2E
EOT	ET	37	04	1E
ENQ	EQ	2D	05	2D
NAK	<sup>N</sup> K	3D	15	3D
DLE	<sup>D</sup> L	10	10	1F
ITB	<sup>I</sup> B(U <sub>S</sub> )	1F	1F	1D
ACK	<sup>A</sup> K	2E	06	-

- A character next to DLE is always displayed unconditionally.
- The results of BCC calculation are displayed when the text is completed.
- Communication sequences are clear to see by changing the display lines.



### Frame level translation display

SDLC, HDLC frame composition

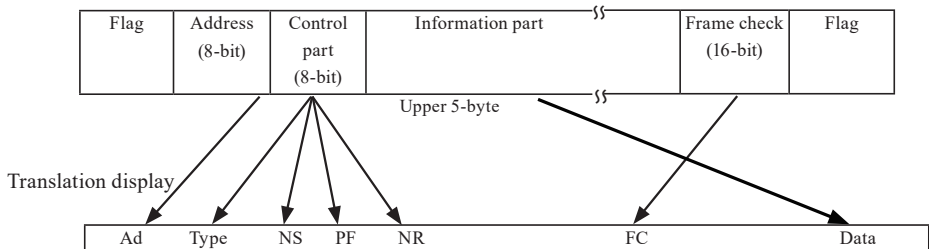

■ SDLC mnemonics chart (modulo 8)

Mnemonic		Name		Control bit configuration							
TXD side	RXD side	TXDside	RXDside	b8	b7	b6	b5	b4	b3	b2	b1
INFO	INFO	INFOmation		N(R)			P/F	N(S)			0
RR	RR	Receive Ready		N(R)			P/F	0	0	0	1
RNR	RNR	Recieve Not Ready		N(R)			P/F	0	1	0	1
REJ	REJ	REJect		N(R)			P/F	1	0	0	1
SNRM		Set Normal Responce Mode		1	0	0	P	0	0	1	1
SNRME		Set Normal Response ModeExtended		1	1	0	P	1	1	1	1
DISC	RD	DISConnect	Request Disconnect	0	1	0	P/F	0	0	1	1
SIM	RIM	Set Initialization Mode	Request InitializationMode	0	0	0	P/F	0	1	1	1
	DM	Disconnect Mode		0	0	0	F	1	1	1	1
UP		Unnumbered Poll		0	0	1	P	0	0	1	1
	UA	Unnumbered Acknowledgement		0	1	1	F	0	0	1	1
UI	UI	Unnumbered IDentification		0	0	0	P/F	0	0	1	1
XID	XID	eXchange IDentification		1	0	1	P/F	1	1	1	1
	FRMR	FReMe Reject		1	0	0	F	0	1	1	1
TEST	TEST	TEST		1	1	1	P/F	0	0	1	1
	BCN	BeaCoN		1	1	1	F	1	1	1	1
CFGR	CFGR	ConFiguRe		1	1	0	P/F	0	1	1	1

☰ When a control unit other than the above bit configuration is received, displayed in HEX.

■ SDLCE mnemonics chart (modulo 128)

Mnemonic	Name	Control bit configuration									
		b16 ~ 10	b9	b8	b7	b6	b5	b4	b3	b2	b1
INFO	INFOmation	N(R)	P/F	N(S)							0
RR	Receive Ready	N(R)	P/F	0	0	0	0	0	0	0	1
RNR	Recieve Not Ready	N(R)	P/F	0	0	0	0	0	1	0	1
REJ	REJect	N(R)	P/F	0	0	0	0	1	0	0	1

☰ When a control unit other than the above bit configuration is received, displayed as in modulo 8.

■ X.25 mnemonics chart (modulo 8)

Mnemonic		Name		Control bit configuration							
TXD side	RXD side	TXD side	RXD side	b8	b7	b6	b5	b4	b3	b2	b1
INFO	INFO	INFOmation		N(R)		P/F		N(S)			0
RR	RR	Receive Ready		N(R)		P/F		0	0	0	1
RNR	RNR	Recieve Not Ready		N(R)		P/F		0	1	0	1
REJ	REJ	REJect		N(R)		P/F		1	0	0	1
SARM	DM	Set Asynchronous Responce Mode	Disconnect Mode	0	0	0	P/F	1	1	1	1
SABM		Set Asynchronous Balanced Mode		0	0	1	P	1	1	1	1
SABME		Set Asynchronous Balanced ModeExtended		0	1	1	P	1	1	1	1
DISC		DISConnect		0	1	0	P	0	0	1	1
	UA	Unnumbered Acknowledgement		0	1	1	F	0	0	1	1
	FRMR	FRaMe Reject		1	0	0	F	0	1	1	1

☞ When a control unit other than the above bit configuration is received, displayed in HEX.

■ X.25E mnemonics chart (modulo 128)

Mnemonic		Name		Control bit configuration							
TXD side	RXD side	TXD side	RXD side	b8	b7	b6	b5	b4	b3	b2	b1
INFO	INFO	INFOmation		N(S)							0
				N(R)							PF
RR	RR	Receive Ready		0	0	0	0	0	0	0	1
				N(R)							P
RNR	RNR	Recieve Not Ready		0	0	0	0	0	1	0	1
				N(R)							PF
REJ	REJ	REJect		0	0	0	0	1	0	0	1
				N(R)							PF

☞ When a control unit other than the above bit configuration is received, displayed as in modulo 8.

LAPD frame composition

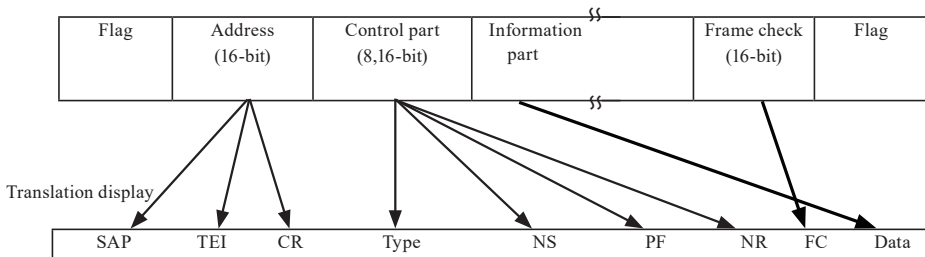

■ LAPD mnemonics chart

Mnemonic		Name		Control bit configuration								
TXD side	RXD side	TXD side	RXD side	b8	b7	b6	b5	b4	b3	b2	b1	
INFO		INFOmation		N(S)								0
				N(R)								P
RR	RR	Receive Ready		0	0	0	0	0	0	0	1	
				N(R)								P/F
RNR	RNR	Recieve Not Ready		0	0	0	0	0	1	0	1	
				N(R)								P/F
REJ	REJ	REJect		0	0	0	0	1	0	0	1	
				N(R)								P/F
SABME		Set Asynchronous BalancedMode Extended		0	1	1	P	1	1	1	1	
				DM	Disconnected Mode	0	0	0	F	1	1	1
UI		Unnumbered Infomation		0	0	0	P	0	0	1	1	
DISC		DISConnect		0	1	0	P	0	0	1	1	
	UA		Unnumbered Acknowledgement	0	1	1	F	0	0	1	1	
	FRMR		FRaMe Reject	1	0	0	F	0	1	1	1	
XID	XID	eXchange IDentification		1	0	1	P/F	1	1	1	1	

☰ When the analyzer receives the control bit configuration other than above, it is displayed in HEX.

◆ This analyzer translates all bit of ACCM is “0”.

Example) When the all bit of ACCM is ON(1):

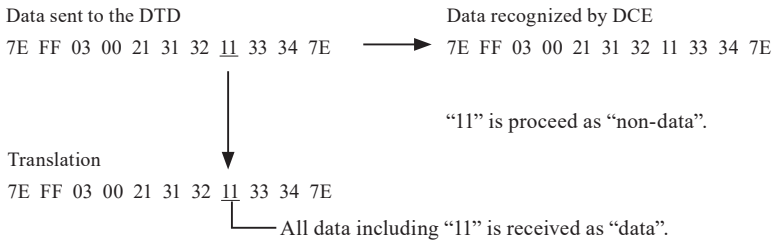

As described in above figure, “11” is recognized as “non-data” in the DCE, however, this analyzer translates and recognizes “11” as “data”.

# Packet level translation display

## ■ X.25 packet composition

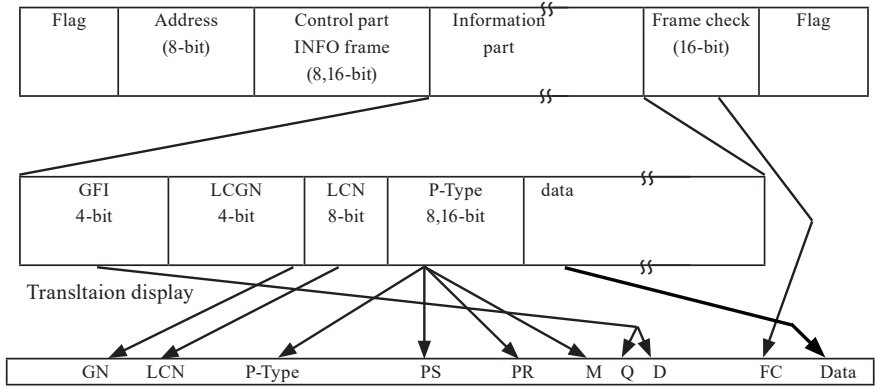

## ■ X.25 mnemonics chart

Mnemonic		Name		Control bit configuration							
TXD side	RXD side	TXD side	RXD side	b8	b7	b6	b5	b4	b3	b2	b1
DT	DT	Data		P(R)		M	P(S)			0	
RR	RR	Receiver Ready		P(R)		0	0	0	0	1	
RNR	RNR	Receve Not Ready		P(R)		0	0	1	0	1	
REJ		REJect		P(R)		0	1	0	0	1	
CR	IC	Call Request	Incoming Call	0	0	0	0	1	0	1	1
CA	CC	Call Accept	Call Connected	0	0	0	0	1	1	1	1
CQ	CI	Clear reQuest	Clear Indication	0	0	0	1	0	0	1	1
CF	CF	Clear conFirmation		0	0	0	1	0	1	1	1
SQ	SI	reStart reQuest	reStart Indication	1	1	1	1	1	0	1	1
SF	SF	reStart conFirmation		1	1	1	1	1	1	1	1
RQ	RI	Reset reQuest	Reset Indication	0	0	0	1	1	0	1	1
RF	RF	Reset conFirmation		0	0	0	1	1	1	1	1
REGQ		REGister(Facility)reQuest		1	1	1	1	0	0	1	1
	REGF	REGister(Facility) conFirmation		1	1	1	1	0	1	1	1
IT	IT	InTerrupt		0	0	1	0	0	0	1	1
IF	IF	Interrupt conFirmation		0	0	1	0	0	1	1	1
DIAG	DIAG	DIAGnostic		1	1	1	1	0	0	0	1

■ LAPD packet configuration

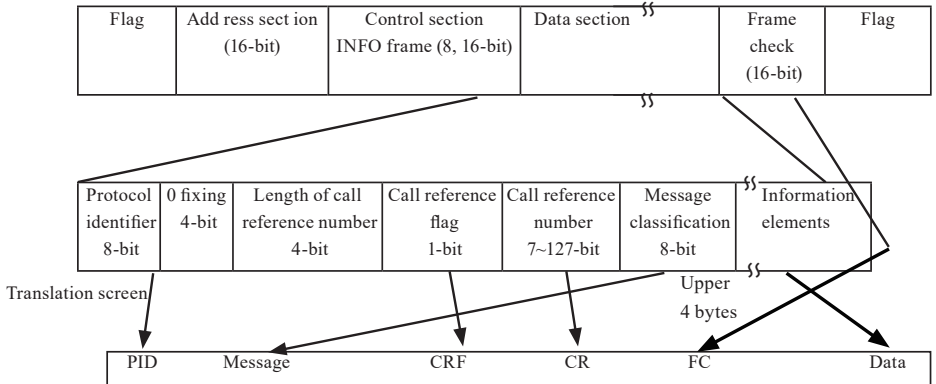

■ LAPD mnemonics chart

Mnemonics	Name	Bit configuration of message							
		b8	b7	b6	b5	b4	b3	b2	b1
ESCAPE	ESCAPE	0	0	0	0	0	0	0	0
ALERT	ALERTing	0	0	0	0	0	0	0	1
CALL PROC	CALL PROCeeding	0	0	0	0	0	0	1	0
CONN	CONNect	0	0	0	0	0	1	1	1
CON NACK	CONNect ACKnowledge	0	0	0	0	1	1	1	1
PROG	PROGress	0	0	0	0	0	0	1	1
SETUP	SETUP	0	0	0	0	0	1	0	1
SETUP ACK	SETUP ACKnowledge	0	0	0	0	1	1	0	1
RES	RESume	0	0	1	0	0	1	1	0
RES ACK	RESume ACKnowledge	0	0	1	0	1	1	1	0
RES REJ	RESume REJect	0	0	1	0	0	0	1	0
SUSP	SUSPend	0	0	1	0	0	1	0	1
SUSP ACK	SUSPend ACKnowledge	0	0	1	0	1	1	0	1
SUSP REJ	SUSPend REJect	0	0	1	0	0	0	0	1
USER INFO	USER INFORMATION	0	0	1	0	0	0	0	0
DISC	DISConnect	0	1	0	0	0	1	0	1
REL	RELease	0	1	0	0	1	1	0	1
REL COMP	RELease COMPLETE	0	1	0	1	1	0	1	0
REST	REStart	0	1	0	0	0	1	1	0
REST ACK	REStart ACKnowledge	0	1	0	0	1	1	1	0
SEGMENT	SEGMENT	0	1	1	0	0	0	0	0
CON CON	CONgestion CONtrol	0	1	1	1	1	0	0	1
INFO	INFORMation	0	1	1	1	1	0	1	1
FAC	FACility	0	1	1	0	0	0	1	0
NOTIFY	NOTIFY	0	1	1	0	1	1	1	0
STATUS	STATUS	0	1	1	1	1	1	0	1
STATUS EN	STATUS ENqiry	0	1	1	1	0	1	0	1



■ PPP frame constitution

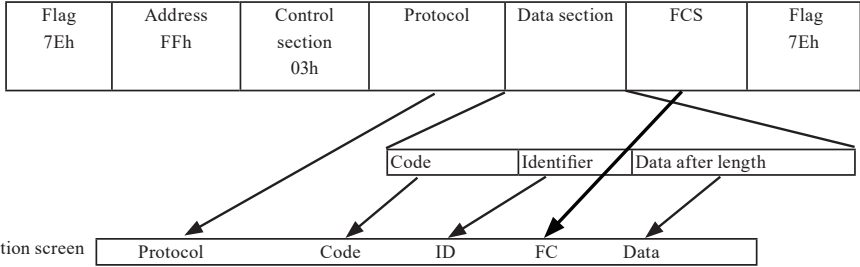

Protocol value (h)	Mnemonic	Name
0001	Padding	Padding Protocol
0021	IP	Internet Protocol
0023	OSI	OSI Network Layer
0025	XNS	Xerox NS IDP
0027	DECnet	DECnet Phase IV
0029	AT	AppleTalk
002b	IPX	Novell IPX
002d	VJCTCPIP	Van Jacobson Compressed TCP/IP
002f	VJUTCPIP	Van Jacobson Uncompressed TCP/IP
0031	BPDU	Bridging PDU
0033	ST	Stream Protocol (TS-II)
0035	VINES	Banyan Vines
0039	AT-EDDP	AppleTalk EDDP
003b	AT-SB	AppleTalk SmartBuffered
003d	MP	Multi-Link
003f	NETBIOS	NETBIOS Framing
0041	Cisco	Cisco Systems
0043	Ascom	Ascom Timeplex
0045	LBLB	Fujitsu Link Backup and Load Balancing
0047	DCA	DCA Remote Lan
0049	SDTP	Serial Data Transport Protocol (PPP-SDTP)
004b	SNA802.2	SNA over 802.2
004d	SNA	SNA
004f	IPv6	IPv6 Header Compression
006f	SB	Stampede Bridging
00fb	CSLMG	Compression on single link in multilink group
00fd	1stComp	1st choice compression
0201	802.1dHP	802.1d Hello Packet
0203	SR-BPDU	IBM Source Routing BPDU
0205	DECLBST	Dec LANBridge 100 Spanning Tree
0231	Luxcom	Luxcom

Protocol value (h)	Mnemonic	Name
233	SigmaNS	Sigma Network Systems
8021	IPCP	Internet Protocol Control Protocol
8023	OSINLCP	OSI Network Layer Control Protocol
8025	XNSCP	Xerox NS IDP Control Protocol
8027	DNCP	DECnet Phase IV Control Protocol
8029	ATCP	Apple Talk Control Protocol
802b	IPXCP	Novell IPX Control Protocol
8031	BCP	Bridging NCP
8035	BVCP	Banyan Vines Control Protocol
803d	MPCP	Multi-Link Control Protocol
803f	NETBIOSC	NETBIOS Framing Control Protocol
8041	CiscoCP	Cisco Systems Control Protocol
8043	AscomCP	Ascom Timeplex
8045	LBLBCP	Fujitsu LBLB Control Protocol
8047	DCA-CP	DCA Remote Lan Network Control Protocol
8049	SDCP	Serial Data Control Protocol (PPP-SDCP)
804b	SNA802CP	SNA over 802.2 Control Protocol
804d	SNACP	SNA Control Protocol
804f	IPv6CP	IPv6 Header Compression Protocol
806f	SBCP	Stampede Bridging Control Protocol
80fb	CSLMGCP	compression on single link in multilink group control
80fd	CCP	Compression Control Protocol
c021	LCP	Link Control Protocol
c023	PAP	Password Authentication Protocol
c025	LQR	Link Quality Report
c027	SPAP	Shiva Password Authentication Protocol
c029	CBCP	CallBack Control Protocol (CBCP)
c223	CHAP	Challenge Handshake Authentication Protocol
c26f	SBAP	Stampede Bridging Authorization Protocol
c281	PropAP	Proprietary Authentication Protocol
c481	PropNIDA	Proprietary Node ID Authentication Protocol



■ Function code

Code	Display	Description
0x01	Read coils	Read Coils
0x02	Read discrete inputs	Read Discrete inputs
0x03	Read holding registers	Read Holding Registers
0x04	Read input registers	Read Input Registers
0x05	Write single coil	Write Single Coil
0x06	Write single register	Write Single Register
0x07	Read exception status	Read Exception Status
0x08	Diagnostics	Diagnostics
0x0B	Get comm event counter	Get Comm Event Counter
0x0C	Get comm event log	Get Comm Event Log
0x0F	Write multiple coils	Write Multiple Coils
0x10	Write multiple registers	Write Multiple registers
0x11	Report slave ID	Report Slave ID
0x14	Read file record	Read File Record
0x15	Write file record	Write File Record
0x16	Mask write register	Mask Write Register
0x17	R-W multiple registers	Read/Write Multiple registers
0x18	Read FIFO queue	Read FIFO queue
0x2B	Encapsulated	Encapsulated Interface Transport

■ Sub-function code

Code	Diagnostics (Diagnostics)	Description
0x00	Diag/Query data	Return Query Data
0x01	Diag/Restart comm	Restart Communications Option
0x02	Diag/Diagnostic register	Return Diagnostic Register
0x03	Diag/ ASCII delimiter	Change ASCII Input Delimiter
0x04	Diag/Force listen only	Force Listen Only Mode
0x0A	Diag/Clear counters	Clear Counters and Diagnostic Register
0x0B	Diag/Bus msg count	Return Bus Message Count
0x0C	Diag/Bus comm err cnt	Return Bus Communication Error Count
0x0D	Diag/Bus except err cnt	Return Bus Exception Error Count
0x0E	Diag/Slave msg count	Return Slave Message Count
0x0F	Diag/Slave no res count	Return Slave No Response Count
0x10	Diag/Slave NAK count	Return Slave NAK Count
0x11	Diag/Slave busy count	Return Slave Busy Count
0x12	Diag/Bus overrun count	Return Bus Character Overrun Count
0x14	Diag/Clear overrun	Clear Overrun Counter and Flag

Code	Encapsulated (Encapsulated)	Description
0x0D	Enca/CANopen general	CANopen General Reference Request and Response PDU
0x0E	Enca/Read device ident	Read Device Identification

■ Modbus detail view (KW1M conformed)

Target function code

- Read Holding Registers(0x03)
- Write Single Register(0x06)
- Write Multiple registers(0x10)

(This function cannot be set to invalid. The function is not perfectly supported because it translates the previous frame as request. And it is impossible to display by converting it to prescale set value.)

Translation displayed	Meaning	Address	Unit
Rate	Rate	0036	
Conversion factor (CO2)	CO2 conversion factor	0037	Kg-CO2
CT type	CT type	003C	
Unit for Pulse output	Unit for pulse output	003D/003E	
Primary side current value	Primary side current value at CT5A	003F	A
Power alarm value	Alarm value (instant effective power)	0040/0041	kW
VT ratio	VT ratio	0042	
Current threshold	Current threshold of time measurement	0043	%
Cutoff current	Cutoff current	0044	%
Current alarm value	Current alarm value (current value)	0045	%
Voltage range	Voltage range	0046	
Current ratio for stan-by alarm	Voltage range	004D	%
Time for stan-by alarm	Standby time for alarm	004E	min
Integral electric power	Integral power consumption	0064/0065	kWh
R-current	R-current	006B	A
S-current	S-current	006C	A
T-current	T-current	006D	A
Power factor	Power factor	006F	PF
Frequency	Frequency	0070	Hz
Load ON-time	Load-ON time	0096/0097	hr
Load OFF-time	Load-OFF time	0098/0099	hr
Pulse count value	Pulse count value	009A/009B	
Preset value	Preset value	009E/009F	
Prescale value	Prescaling value	00A0/00A1	
Max. counting speed	Max. counting speed	00A2	Hz
Auto-off time	Auto-off time	00A3	min
R(RS)-voltage	R(RS)-voltage	00AA/00AB	V
S(RT)-voltage	S(RT)-voltage	00AC/00AD	V
T(TS)-voltage	T(TS)-voltage	00AE/00AF	V
Instantaneous electric power	Instantaneous electric power	00B0/00B1	kW

Modbus protocol (conforming to KW1M) is displayed as following.

Function Codes	Request		Response	
	Translation	Value	Translation	Value
Read coils (0x01)	Starting address	HEX	Byte count	Decimal
	Quantity	Decimal	Status	Binary
Read discrete inputs (0x02)	Starting address	HEX	Byte count	Decimal
	Quantity	Decimal	Input status	Binary
Read holding registers (0x03)	Starting address	HEX	Byte count	Decimal
	Quantity	Decimal	Register value	HEX
Read input registers (0x04)	Starting address	HEX	Byte count	Decimal
	Quantity	Decimal	Input registers	HEX
Write single coil (0x05)	Output address	HEX	Output address	HEX
	Output value	ON/OFF/ HEX	Output value	ON/OFF/ HEX
Write single register (0x06)	Register address	HEX	Register address	HEX
	Register value	HEX	Register value	HEX
Read exception status (0x07)			Output data	Binary
Diagnostics (0x08)	Data	HEX	Data	(*1)/HEX
			Count	(*1)/10Decimal
Get comm event counter (0x0B)			Status	HEX
			Event count	Decimal
Get comm event log (0x0C)			Byte count	Decimal
			Status	HEX
			Event count	Decimal
			Message count	Decimal
			Event	Binary
Write multiple coils (0x0F)	Starting address	HEX	Starting address	HEX
	Quantity	Decimal	Quantity	1Decimal
	Byte count	Decimal		
	Outputs value	Binary		
Write multiple registers (0x10)	Starting address	HEX	Starting address	HEX
	Quantity	Decimal	Quantity	Decimal
	Byte count	Decimal		
	Registers value	HEX		
Report slave ID (0x11)			Byte count	Decimal
			Data	Binary
Read file record (0x14)	Byte count	Decimal	Response data length	Decimal
	Reference type	HEX	File response length	Decimal
	File number	Decimal	Reference type	HEX
	Record number	Decimal	Record data	HEX
	Record length	Decimal		

Write file record (0x15)	Request data length	Decimal	Response data length	Decimal
	Reference type	HEX	Reference type	HEX
	File number	Decimal	File number	Decimal
	Record number	Decimal	Record number	Decimal
	Record length	Decimal	Record length	Decimal
	Record data	HEX	Record data	HEX
Mask write register (0x16)	Reference address	HEX	Reference address	HEX
	And_Mask	HEX	And_Mask	HEX
	Or_Mask	HEX	Or_Mask	HEX
R-W multiple registers (0x17)	Read starting address	HEX	Byte count	Decimal
	Quantity to read	Decimal	Read registers value	HEX
	Write starting address	HEX		
	Quantity to write	Decimal		
	Write registers value	HEX		
Read FIFO queue (0x18)	FIFO pointer address	HEX	Byte count	Decimal
			FIFO count	Decimal
			FIFO value register	HEX
Encapsulated (0x2B)	MEI type	(*2)/HEX	MEI type	(*2)/HEX
	Read device ID code	(*2)/HEX	Read device ID code	(*2)/HEX
	Object ID	(*2)/HEX	Conformity level	(*2)/HEX
			More follows	(*2)/HEX
			Next object ID	(*2)/HEX
			Number of objects	(*2)/Decimal
			Object ID	(*2)/HEX
			Object length	(*2)/HEX
		Object value	String(*2/*3)	

\*1:Refer to “Sub-function (Detailed translation)” in the appendix.

\*2:Refer to “MEI type (Detailed translation)” in the appendix.

\*3:It could not be displayed all depending on the character length or character type.

■ Sub-function(Detailed translation)

Sub-function	Display	Display
0	Return query data	HEX
1	Restart communications option	HEX
2	Return diagnostic register	HEX
3	Change ASCII input delimiter	HEX
4	Force listen only mode	HEX
10	Clear counters and diagnostic register	HEX
11	Return bus message count	Decimal
12	Return bus communication error count	Decimal
13	Return bus exception error count	Decimal
14	Return server message count	Decimal
15	Return server no response count	Decimal
16	Return server NAK count	Decimal
17	Return server busy count	Decimal
18	Return bus character overrun count	Decimal
20	Clear overrun counter and flag	HEX
	Others	HEX

■ MEI type(Detailed translation)

MEI type	Display	Remarks
0x0D	CANopen general reference command	No translation after MEI type
0x0E	Read device identification	
Others	HEX	

Object Id / Next object Id	Display
0x00	Vendor name
0x01	Product code
0x02	Major Minor revision
0x03	Vendor Url
0x04	Product name
0x05	Model name
0x06	User application name
Others	HEX

■ Exception code (Detailed translation)

Code	Display
0x01	ILLEGAL FUNCTION
0x02	ILLEGAL DATA ADDRESS
0x03	ILLEGAL DATA VALUE
0x04	SLAVE DEVICE FAILURE
0x05	ACKNOWLEDGE
0x06	SLAVE DEVICE BUSY
0x08	MEMORY PARITY ERRERE
0x0A	GATEWAY PATH UNAVAILABLE
0x0B	GATEWAY TARGET DEVICE FAILED TO RESPOND
Others	HEX



■ Function code

Function Code Request

Code								Meaning	Translation
b7	b6	b5	b4	b3	b2	b1	b0		
1	1	x	x	0	0	0	0	Clock Value	CV
0	1	x	x	0	0	0	0	Time Event	TE
0	1	x	x	0	0	1	1	Send Data Acknowledged - low priority	SDA_LOW
0	1	x	x	0	1	0	0	Send Data Not acknowledged - low priority	SDN_LOW
0	1	x	x	0	1	0	1	Send Data Acknowledged - high priority	SDA_HIGH
0	1	x	x	0	1	1	0	Send Data Not acknowledged	SDN_HIGH
0	1	x	x	0	1	1	1	Send Request Data with Multicast Reply	MSRD
0	1	x	x	1	0	0	1	Request FDL Status	REQ_FDL
0	1	x	x	1	1	0	0	Send and Request Data	SRD_LOW
0	1	x	x	1	1	0	1	Send and Request Data	SRD_HIGH
0	1	x	x	1	1	1	0	Request Ident with reply	REQ_ID
0	1	x	x	1	1	1	1	Request LSAP Status with reply	REQ_LSAP

Function Code Response

Code								Meaning	Translation
b7	b6	b5	b4	b3	b2	b1	b0		
0	0	x	x	0	0	0	0	OK	OK
0	0	x	x	0	0	0	1	User Error	UE
0	0	x	x	0	0	1	0	No resources	RR
0	0	x	x	0	0	1	1	SAP not enabled	RS
0	0	x	x	1	0	0	0	Data Low (normal case with DP)	DL
0	0	x	x	1	0	0	1	No response data ready	NR
0	0	x	x	1	0	1	0	Data High (DP diagnosis pending)	DH
0	0	x	x	1	1	0	0	Data not received and Data Low	RDL
0	0	x	x	1	1	0	1	Data not received and Data High	RDH

“x” means the “don’t care” and they are masked.

# Chapter 11 Specifications and Maintenance

## 11.1 Specifications of Function and Hardware

Item	LE-8500X-RT / LE-8500XR-RT
Interface	RS-232C, RS-530,RS-422/RS-485, TTL(1.8V,2.5V,3.3V,5Vlevel)
Protocol	ASYN, ASYN-PPP, Character SYNC/BSC, HDLC/SDLC/X.25, CC-LINK, Modbus, PROFIBUS, I2C,I3C <sup>1</sup> , SPI, Burst
Measurement expansion option <sup>*2</sup>	Dedicated cable: X.20/21, RS-449, V.35 SB-GE2: LAN (GbE), PoE SB-FE2: LAN (zero latency, EtherCAT compatible), PoE SB-TIE: Single-pair Ethernet, PoDL SB-C2AN: CAN, CAN FD, analog measurement
Capture memory	1GB. Able to divide it in two.
Max. speed <sup>*3</sup>	Full-duplex: 10Mbps Half-duplex: 20Mbps SPI:30Mbps <sup>*4</sup>
Communication speed setting	Normal Mode: 50bps to 12Mbps In high-speed mode: 50bps to 20Mbps (30Mbps for only SPI) Can be set by 4 significant digits separately for transmission and reception (error: $\pm 0.01\%$ )
Data format	NRZ, NRZI, FM0, FM1, Manchester0, Manchester1
Data code	ASCII,EBCDIC,JIS, Baudot, Transcode, IPARS, EBCD, EBCDIK, HEX
Measurement function	Monitor function, Simulation function, BERT function
External trigger	LVTTL input 1, Open collector output 2
Signal voltage measurement	$\pm 12V$ input range, 0.1V resolution <sup>*5</sup>
CSV Conversion	Measurement data can be converted and saved to a CSV format file.
TXT Conversion	Measurement data can be converted and saved to a TXT format file.
Auto save Function	Monitored data is automatically saved as a log file in the USB memory/SDHC while it keeps monitoring. <sup>*6</sup>
Useful Function	Time synchronized function from PPS of GNSS signal or external PPS signal . Auto back-up function. Auto RUN/STOP function. Power on run function
Logic analyzer function	1KHz to 200MHz, maximum 4096 sampling
LCD display	7 inch TFT color display (480x272dot) with capacitive touch panel
LED	11 LEDs for the line state and 1 LED for the power
LAN Port	RJ45 connector for PC connection. 1000BASE-T Ethernet: IEEE 802.3
USB device port	Type-C connector for PC connection. Super Speed supported.
USB host port	Standard A connector for USB memory. Super Speed supported.
SD card slot	For standard size of SD/SDHC memory card. Compliant with SD association standard.
PPS signal I/O terminal	Uses the external trigger I/O terminal
GPS Antenna Connector	SMA( female ) connector
Wi-Fi interface <sup>*7</sup>	IEEE802.11b/g/n. Frequency range: 2412MHz : 2484 MHz • Transmission power 802.11b: +18.5dBm 802.11g: +18.0dBm 802.11n: +17.0dBm
Printout function	Measurement data can be output to printer.Screen image can be output to printer.
Power	Attached AC adapter. Lithium-ion rechargeable battery (model : P-26LW2) Battery drive time: 4 hours <sup>*8</sup>
Temperature	In operation : 0 ~ 40°C In storage : -20 ~ 50°C
Humidity	20 ~ 85%RH (no condensation)
Standard	CE ( class A )
Dimensions (W×D×H) ,Weight	234(W)×186(D)×44(H) mm, Approx. 990g

- \* 1 : Requires system version 1.15 or later. For monitor function only. It can measure SDR communication data and detect Target Reset, HDR Exit, and HDR Restart patterns.
- \* 2 : Optional measurement board or optional cable is required depending on the target.
- \* 3 : The maximum measurable speed is limited by the selected interface and protocol. When measuring a line with an effective transfer rate of 5Mbps or higher, it is supported by switching the analyzer to the high-speed mode.
- \* 4 : Maximum 15Mbps for the slave mode simulation.
- \* 5 : TXD/TXD-, ,TXD+,TXD/RXD-, and DTE of RS232C,RS-422/485 and 4 communication lines of can be measured.
- \* 6 : 4 All frames may not be recorded in the storage because of the high traffic line or low performance of the external storage.
- \* 7 : For LE-8500XR-RT only. For PC connection.
- \* 8 : According to our test conditions assuming a normal usage situation.

## 11.2 Signal Definition of the Measurement Ports

### 2.3 Measurement Port

#### ○ RS-232C/RS-530 port

It is for RS-232C/RS-530 port. To use it for X.20/X.21/RS-449/V.35 port with optional cables, select RS-530 port ([Menu] -> “interface” -> “port”).

#### ■ Signal definition of the RS-232C

Name	RS-232C(V.24)		Input/Output <sup>(*)3</sup>			JIS name <sup>(*)4</sup>
	DSUB25	Pin <sup>(*)2</sup>	MONITOR	DTE	DCE	
Shield grand	FG	1	-	-	-	
Signal grand	SG	7	-	-	-	
Transmitted data	TXD	2	I	O	I	SD
Received data	RXD	3	I	I	O	RD
Request to send	RTS	4	I	O	I	RS
Clear to send	CTS	5	I	I	O	CS
Data terminal ready	DTR	20	I	O	I	ER
Data set ready	DSR	6	I	I	O	DR
Data carrier detect	DCD	8	I	I	O	CD
Call indicator	RI <sup>(*)1</sup>	22	I	I	-	CI
Send timing DTE	TXC1	24	I	O	I	ST1
Send timing DCE	TXC2	15	I	I	O	ST2
Receive timing DCE	RXC	17	I	I	O	RT

- \* 1: RI signal cannot be transmitted from the analyzer.
- \* 2: Pins not mentioned are not connected.
- \* 3: Input direction to this analyzer is I, output direction from this analyzer is O.
- \* 4: The signal names of JIS standard are used in former model (LE-8200 etc.).

■ Signal definition of RS-422/485 port (V35 Mode=off)

Signal	RS-530(standard)		X.20/21(*1)		RS-449(*2)		Input/Output(*3)		
	Dsub25	Pin	Dsub15	Pin	Dsub37	Pin	MONITOR	SIM-DTE	SIM-DCE
Shield ground	FG	1	FG	1	FG	1	-	-	-
Transmission data	TXD[A]:-	2	T [A]:-	2	SD[A]:-	4	I	O	I
	TXD[B]:+	14	T [B]:+	9	SD[B]:+	22	I	O	I
Receiving data	RXD[A]:-	3	R [A]:-	4	RD[A]:-	6	I	I	O
	RXD[B]:+	16	R [B]:+	11	RD[B]:+	24	I	I	O
Request to send	RTS[A]:-	4	C [A]:-	3	RS[A]:-	7	I	O	I
	RTS[B]:+	19	C [B]:+	10	RS[B]:+	25	I	O	I
Clear to send	CTS[A]:-	5	I [A]:-	5	CS[A]:-	9	I	I	O
	CTS[B]:+	13	I [B]:+	12	CS[B]:+	27	I	I	O
Data set ready	DSR[A]:-	6			DM[A]:-	11	I	I	O
	DSR[B]:+	22			DM[B]:+	29	I	I	O
Terminal ready	DTR[A]:-	20			TR[A]:-	12	I	O	I
	DTR[B]:+	23			TR[B]:+	30	I	O	I
Signal ground	SG	7	SG	8	SG	19	-	-	-
Data carrier Detect	DCD[A]:-	8			RR[A]:-	13	I	I	O
	DCD[B]:+	10			RR[B]:+	31	I	I	O
Transmission timing DTE	TXC1[A]:-	24			TT[A]:-	17	I	O	I
	TXC1[B]:+	11			TT[B]:+	35	I	O	I
Transmission timing DCE	TXC2[A]:-	15			ST[A]:-	5	I	I	O
	TXC2[B]:+	12			ST[B]:+	23	I	I	O
Receiving timing DCE	RXC[A]:-	17	S [A]:-	6	RT[A]:-	8	I	I	O
	RXC[B]:+	9	S [B]:+	13	RT[B]:+	26	I	I	O
	Not connected	18							
	Not connected	21							
	Not connected	25							

\*1: Defines Dsub15 pin signal when the dedicated cable LE-25Y15 (option) is connected.

☐ To measure X.21 interface with LE-25Y15, set “clock” to “RT” or “AR”.

\*2: Defines Dsub37 pin signal when the dedicated cable LE-25Y37 (option) is connected.

\*3: “I” is an input to the analyzer. “O” is an output from the analyzer.

■ Signal definition of RS-422/485 port (V35 Mode=on)

Signal	Port status		V.35 (*1)		Input/Output (*2)		
	Dsub25	Pin	M type 34	Pin	MONITOR	DTE	DCE
Shield ground	FG	1	FG	A	-	-	-
Transmission data	TXD[A]:-	2	TXD[A]:-	P	I	O	I
	TXD[B]:+	14	TXD[B]:+	S	I	O	I
Receiving data	RXD[A]:-	3	RXD[A]:-	R	I	I	O
	RXD[B]:+	16	RXD[B]:+	T	I	I	O
Data set ready	V24_DSR	6	V24_DSR	E	I	I	O
Terminal ready	V24_DTR	20	V24_DTR	H	I	O	I
Signal ground	SG	7	SG	B	-	-	-
Data carrier Detect	V24_DCD	8	DCD	F	I	I	O
Ring indicator	V24_CI	10	CI	J	I	I	O
Transmission timing DTE	TXC1[A]:-	24	TXC1[A]:-	U	I	O	I
	TXC1[B]:+	11	TXC1[B]:+	W	I	O	I
Transmission timing DCE	TXC2[A]:-	15	TXC2[A]:-	Y	I	I	O
	TXC2[B]:+	12	TXC2[B]:+	AA	I	I	O
Receive timing DCE	RXC[A]:-	17	RXC[A]:-	V	I	I	O
	RXC[B]:+	9	RXC[B]:+	X	I	I	O
Request to send	V24_RTS	18	RTS	C	I	O	I
Clear to send	V24_CTS	21	CTS	D	I	I	O

\*1: Defines M type 34 pin signal when the dedicated cable LE-25M34 (option) is connected.

\*2: "I" is an input to the analyzer. "O" is an output from the analyzer.

○ RS-422/485 port

RS-422/485 measurement/test port.

■ Signal definition of RS-422/485 port

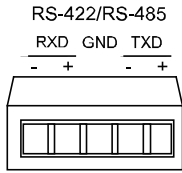

Signal	Terminal	Input/Output <sup>(*)</sup>			Line state LED
		MONITOR	DTE	DCE	
Transmission data	TXD-	I	O	I	TXD
	TXD+	I	O	I	
Receiving data	RXD-	I	I	O	RXD
	RXD+	I	I	O	
Signal Ground	GND	-	-	-	

\*1: "I" is an input to the analyzer. "O" is an output from the analyzer.

○ TTL Port

TTL (UART), SPI, and I2C port for measurement and test.

TTL Port

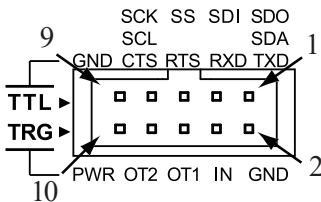

Connector : 2.54mm pitch Pin header type  
HIF3FC-10PA-2.54DS(71)  
HIROSE ELECTRIC

■ TTL(UART) signal definition

Signal	Pin name	Pin	Input/Output <sup>(*)</sup>		Line state LED
			MONITOR	SIMULATION	
Transmission data	TXD	1	I	O	TXD
Receiving data	RXD	3	I	I	RXD
RTS	RTS	5	I	O	RTS
CTS	CTS	7	I	I	CTS
Signal Ground	GND	9	-	-	

■ I2C signal definition

Signal	Pin name	Pin	Input/Output <sup>(*)</sup>			Line state LED
			MONITOR	SIMULATION		
				MASTER	SLAVE	
SDA	SDA	1	I	I/O	I/O	SDA
SCL	SCL	7	I	O	I	SCL
Signal Ground	GND	9	-	-		

■ SPI signal definition

Signal	Pin name	Pin	Input/Output <sup>(*1)</sup>			Line state LED
			MONITOR	SIMULATION		
				MASTER	SLAVE	
MOSI	SDO	1	I	O	O <sup>(*2)</sup>	MOSI
MISO	SDI	3	I	I	I <sup>(*2)</sup>	MISO
SS	SS	5	I	O	I	SS
SCK	SCK	7	I	O	I	SCK
Signal Ground	GND	9	-	-	-	

■ Signal definition of the external trigger

Signal	Pin name	Pin	Input/Output <sup>(*1)</sup>	Signal level
External trigger input	IN	4	I	LLVTTL(3.3V) / External PPS input
External trigger output1	OT1	6	O	open collector 5V pull-up
External trigger output2	OT2	8	O	open collector 5V pull-up / External PPS output
Power for the external circuit	PWR	10	O	TTL voltage output <sup>(*3)</sup>

\*1 :“I” is an input to the analyzer. “O” is an output from the analyzer.

\*2 :For SLAVE simulation, connect the SDO of this unit to the MISO to be tested and the SDI of this unit to the MOSI to be tested.

\*3 :When the measurement port is set to TTL and the simulation is executed, the set TTL voltage is output (max. 30mA).

## 11.3 Shortcut Keys

The shortcut key operation similar to the operation by the menu number of the conventional model is available. By pressing [0] to [F] after [MENU], you can move to the frequently used setting screen.

Shortcut key	Setting display	Remark
[MENU],[0]	Configuration	
[MENU],[1]	Interface	
[MENU],[2]	Trigger	
[MENU],[4]	Digital Wave Monitor	
[MENU],[9]	Data Table Transmission	
[MENU],[A]	Except for some pages, by these operations, the functions in the touch operation guide at the bottom of the screen will be executed. (Assigned to A, B, C, D, E from the left of the guide)	(*)
[MENU],[B]		
[MENU],[C]		
[MENU],[D]		
[MENU],[E]		

- ☰ If the transition destination setting screen is not valid for the current function or operation mode, such as pressing the [MENU] or [9] key in online monitor function, the operation will be ignored.
- ☰ Please note that the shortcut key operation with (\*) is different from the operation by the menu number of the conventional model.

## 11.4 Expansion of measurement interface

The shortcut key operation similar to the operation by the menu number of the conventional model is available. By pressing [0] to [F] after [MENU], you can move to the frequently used setting screen.

### ■ Board replacement

Turn off the analyzer and disconnect all cables, then remove the standard interface sub-board and replace it with the optional sub-board.

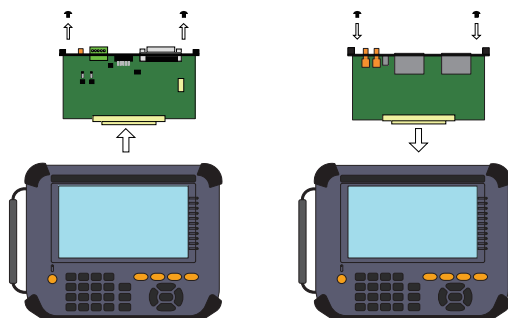

### ■ Firmware

The firmware that corresponds to the installed interface sub-board will start automatically. If the version of firmware installed on the main unit is old and does not correspond to the expansion option sub-board, the unit will start in firmware update mode, so please update to the latest firmware.

 11.6 How to update the firmware

## 11.5 Factory reset

By the Factory reset operation, you can initialize the internal status of this analyzer and return the settings to the factory settings.

### ■ How to

Tap “Factory reset” on the “Version” tab of “System Settings”. If you tap “OK” in the confirmation message, the main unit will automatically shut down and the settings will be initialized when you boot it next time.

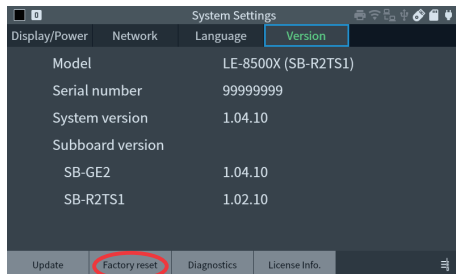

## 11.6 How to update the firmware

For this analyzer updating the firmware and recovering by writing back the entire system are available.

The latest firmware file and system recovery file can be downloaded from the LINEEYE website.

[https://www.lineeye.co.jp/html/download\\_update.html](https://www.lineeye.co.jp/html/download_update.html)

Download it to an easy-to-find folder on your PC, unzip it, and check the firmware file (extension: FW3) or system recovery file (extension: FWR).

The downloaded file can be written to the analyzer by the following method.

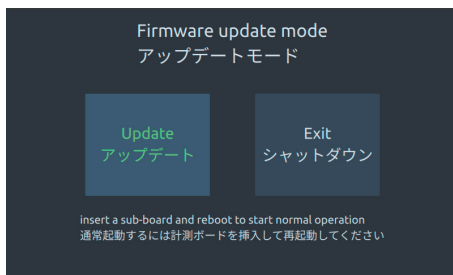

- 1) Copy the firmware file or system recovery file to a storage device (USB memory or SDHC card). Normally you would use a firmware file.
- 2) From “System Settings” → “Version” tap “Update” to restart the analyzer.
- 3) After rebooting, the boot logo will be displayed and then the firmware update mode screen will appear.



- 4) Insert the storage device where you copied the firmware file or system recovery file into the analyzer.
- 5) On the firmware update mode screen, tap “Update”.
- 6) Select Firmware File or System Recovery File.
- 7) In the case of system recovery files, a message will be displayed warning that the settings will be initialized.
- 8) It display the message when the firmware update or system recovery is completed. Tap “OK” to reboot.
- 9) To check the updated firmware version, go to “System Settings” → “Version”.

## 11.7 Trouble shooting

- This section describes how to solve problems when the analyzer does not operate normally.

Problem	Cause / Remedy
Cannot turn on the power. The power turns off immediately.	<ul style="list-style-type: none"> <li>• When operating by the battery, fully charge it.</li> <li>• If the attached AC adapter is connected but it does not improve, it may be broken.</li> <li>• If the power does not turn on, press and hold the power switch for about 1 second.</li> </ul>
Unable to charge Unable to charge enough.	<ul style="list-style-type: none"> <li>• If the power LED (red) is not lit, connect the AC adapter.</li> <li>• It cannot be charged at extremely low or high temperatures. Charge at 5 to 40°C.</li> <li>• If the battery is fully charged but the power runs out shortly, the battery may be dead.</li> </ul>
The backlight turns on but it goes out immediately.	<ul style="list-style-type: none"> <li>• Select the appropriate automatic dimming time of the backlight at the “System Settings” tab of “Display/Power” in the top menu.</li> </ul>
When it starts up, the firmware update screen appears.	<ul style="list-style-type: none"> <li>• Set the sub board securely.</li> <li>• Load the necessary firmware for the optional sub board used at the moment.</li> </ul>
When [RUN] is executed, the previous measurement data disappeared.	<ul style="list-style-type: none"> <li>• Set automatic backup at the “Auto Save” tab of “Record Control” in the top menu.</li> </ul>
The date and time of the time stamp are incorrect.	<ul style="list-style-type: none"> <li>• At the clock display on the top menu set the current date and time before measurement.</li> <li>• If the date and time often go wrong, the built-in lithium battery may have run out.</li> </ul>
Keys does not work.	<ul style="list-style-type: none"> <li>• Key operation is not possible during internal processing such as access to storage device.</li> <li>• Try to press the power switch shortly to reset the delay in key operation circuit.</li> <li>• While using the PC link software of utility software, key operation is not available. Cut the remote connection from the software.</li> </ul>
Does not work properly. Some of the display is incorrect.	<ul style="list-style-type: none"> <li>• Turn off the power and then turn it on again.</li> <li>• Reset the software (“System setting” -&gt; “Version” -&gt; “Initialization”). It will go back to the factory setting. Please save the important data before resetting the software. It will erase all data.</li> <li>• If it still does not work, perform the system recovery.</li> </ul> <p style="text-align: right;"> 11.6 How to update the firmware</p>
Line state LED does not light.	<ul style="list-style-type: none"> <li>• Connect the cable correctly.</li> <li>• Match the interface settings with the specification of the measurement target.</li> <li>• Check if there is any broken wire or loose connector.</li> </ul>
An SD card cannot be used on the analyzer	<ul style="list-style-type: none"> <li>• SD (SDXC) card of more than 32GB is not supported.</li> <li>• Please use optional SD card from LINEEYE.</li> </ul>
An USB card cannot be used on the analyzer	<ul style="list-style-type: none"> <li>• USB flash drive formatted by exFAT and NTFS is not supported.</li> <li>• Try another USB flash drive.</li> </ul> <p style="text-align: right;"> 7.1 Storage device</p>
The Wi-Fi function cannot be used.	<ul style="list-style-type: none"> <li>• Wi-Fi function is available only in Japan, USA, Canada and EU countries.</li> <li>• Check if the Wi-Fi SSID and KEY are set correctly.</li> <li>• Move to a location where radio waves can be easily received.</li> </ul>

Problem	Cause / Remedy
Cannot connected to a computer via the USB port.	<ul style="list-style-type: none"> <li>• Connect the USB connector well.</li> <li>• Check if the connection is blocked by security softwares.</li> </ul>
Cannot connect to the PC via LAN port	<ul style="list-style-type: none"> <li>• Conform the IP address and other network setting.</li> <li>• Try another LAN cable.</li> </ul>
Cannot understand the signal names of line state LEDs.	<ul style="list-style-type: none"> <li>• Press [SHIFT] + [MENU]</li> </ul>
Line state LED is blinking, however, the analyzer does not monitor or display anything.	<ul style="list-style-type: none"> <li>• Select “Online monitor” function.</li> <li>• Set the correct communication conditions from [MENU]-&gt;[0]. Confirm the communication speed, frame end time and frame end code.</li> </ul>
Line state LED is blinking, however, the analyzer does not monitor.	<ul style="list-style-type: none"> <li>• Select “Online monitor” function.</li> <li>• Set the correct communication conditions from [MENU]-&gt;[0]. Confirm the data bit, parity bit, FCS and BCC.</li> </ul>
After press [RUN], there are some communication errors in the target line.	<ul style="list-style-type: none"> <li>• Select “Online monitor” function.</li> <li>• If selecting “Simulation” function, the analyzer transmits signals and causes some errors.</li> </ul>
Data is not transmitted by Simulation or BERT function.	<ul style="list-style-type: none"> <li>• Select “Simulation” or “BERT” function.</li> <li>• Set the correct interface from [MENU]-&gt;[1].</li> <li>• Set the correct communication conditions from [MENU]-&gt;[0]. For SYNC and HDLC protocol, conform the frame end time.</li> </ul>
Cannot monitor using the auto configuration.	<ul style="list-style-type: none"> <li>• Auto configuration is available for ASYNC, SYNC/BSC, HDLC/SDLC only.</li> <li>• This function is not available if the communication speed is above 1.544Mbps.</li> <li>• This function is not available if there is not enough communication.</li> </ul>
Cannot turn of the power.	<ul style="list-style-type: none"> <li>• Press the power button for more than 10 seconds. It will switch off the power forcibly.</li> </ul>

## 11.8 Warranty and After service

---



### Warranty

---

- When you face any problems, please contact LINEEYE distributors or LINEEYE
- Warranty

Within a period of 12 months from the date of shipment, LINEEYE warrants that your purchased products (except consumable parts such as the battery and software) are free of charge from any defects in material and workmanship, only when the products are operated in accordance with procedures described in the documents supplied by LINEEYE. If the defects exist during the Warranty period, please send back the products to LINEEYE distributors or LINEEYE. LINEEYE will repair or exchange them at no charge. In this case, the shipping charge will be at your own expense.

The foregoing warranties are the sole warranties given by LINEEYE. Above warranties shall not be applied to the products that have been modified, repaired or altered (except by LINEEYE) or that have been subjected to unusual physical or electrical stress, misuses, abuse, negligence or accidents.

LINEEYE disclaims all other warranties including the warranties of merchantability fitness for some particular purpose and noninfringement of third party right. LINEEYE cannot promise that the software is error free or will operate without any interruption.



### User Registration

---

User registration is required to receive appropriate after-sales support.

Please register as a user using the user registration form on our website.

<https://www.lineeye.co.jp/html/support.html>



### Repair

---

For malfunction, please contact LINEEYE distributors or LINEEYE and tell us following details.

Model	LE-8500X-RT or LE-8500XR-RT
Serial Number	The serial number of 8-digit alphanumerical
Purchase Date	Year, Month, Day
Other	Details of malfunction



### 11.7 Trouble shooting

- Repair during warranty period  
LINEEYE repairs, following the repair instruction.  
Please provide the details of malfunction.
- Repair after warranty period  
LINEEYE will repair the products at our own expense.



## Maintenance parts

---

Maintenance parts such as lithium-ion batteries, attached cables, and AC adapters can be purchased from the store where you purchased the product or from our online shop.

■ About recycling of lithium-ion batteries

Please recycle the replaced old battery in accordance with the local laws and regulations of each country.



## After Support

---

Read “FAQ” in our Website or email us.

Please refer to “FAQ” . We also have support by email regarding the technical issue. When you use it, please register your product via our website.

Website : <https://www.lineeye.co.jp/>

## LINEEYE CO., LTD.

4F., Marufuku Bldg., 39-1, Karahashi Nishihiragaki-cho, Minami-ku,  
Kyoto, 601-8468, Japan

Tel : 075(693)0161 Fax : 075(693)0163

URL <https://www.lineeye.com> Email :[info@lineeye.co.jp](mailto:info@lineeye.co.jp)

Printed in Japan