

# LINEEYE

*MULTI PROTOCOL ANALYZER*

***LE-8600XR***

***LE-8600X***

---

---

## INSTRUCTION MANUAL

---

---



# Instruction

---

---

Thank you for your purchase of LE series.

To use it correctly, you are advised to read and understand this instruction manual thoroughly. Keep this together with the warranty. If you encounter any problems, you will find helpful information in this manual.



## NOTICE

---

It is prohibited to reprint or duplicate any part of the whole of this instruction manual without prior permission from LINEEYE.

The content of this instruction manual and specifications of the products are subject to change without any notice.

This instruction manual has been designed and edited with great care to give you all necessary information. If you have any questions, feel free to direct your inquiries to LINEEYE.

LINEEYE makes no warranty or guarantee, either expressed or implied with respect to its quality, performance, merchantability, or fitness for a particular purpose. LINEEYE shall not be liable for direct, indirect, special, incidental, or consequential damages resulting from any defect in the product. The warranty and remedies set forth above are exclusive and in lieu of all others.



## USER LIMITATION

---

This product has not been developed for the use that needs exclusively high reliability and safety: aerospace apparatus, trunk communication apparatus, nuclear control apparatus, medical apparatus related with life maintenance etc. Therefore, do not use for those purposes.

LE-series models with Wi-Fi function (IEEE 802.11b/g/n) emit radio wave. Please do not use it near a medical device, microwave, high-level electronics, TV, radio, wireless station for mobile communication, or specified low power radio station. To use LE-series in the place where an administrator limits the use of radio devices, follow the instruction of the administrator.

The Wi-Fi module used for the LE-series conforms to SRRC(China), FCC (USA), CE (EU), TELEC (Japan), KCC (Korea), ISED (Canada), NCC (Republic of China), however, as its product (LE-series) the Wi-Fi function is available only in Japan, USA, Canada, and EU nations in compliance with RE directive (2014/53/EU).

To use the product other than above countries, order LE-series without Wi-Fi function. Please contact the sales department for more details.

=== Notice ===

This product contains a lithium-ion battery.

To keep the quality of the battery, LINEEYE does not fully charge the battery.

Before using the battery, please make sure to charge the battery. When you

dispose it, please recycle it in accordance with the local laws and regulations of each country.

2022 by LINEEYE CO., LTD. All rights reserved

# Safety Information



## Read this first !!

This Safety Information includes the following important information in order to not only have you learn the right way to use the analyzer, but also prevent you from causing damage to people and property. Before using,

please read the main contents after you understand the following symbols & marks.



**Warning**

Should the device be used without following these symbols, there is a possibility of accidents, such as a death or a serious injury, occurring.



**Caution**

Should the device be used without following these symbols, there is a possibility of accidents, such as an injury (\*1), and material damage (\*2) occurring.

\*1 : "Injury" indicates injury, burn and electric shock, or the like which does not require hospitalization or the extended hospital visit.









\*2 : "Material damage" indicates damage related to a house, a building, furniture, apparatus, livestock or a pet.







Prohibition





The necessary

 <b>Warning</b>	
	<ul style="list-style-type: none"> <li>Do not disassemble, modify or repair the line monitor This may result in an injury, electric shock, and ignition.</li> </ul>
	<ul style="list-style-type: none"> <li>Turn off the power of analyzer and unplug the cables immediately when emanating smoke, odor or sound. Continuous use may result in an electric shock, injure or ignition.</li> </ul>
	<ul style="list-style-type: none"> <li>Do not use the line monitor if there is inflammable gas. This may result in ignition and explosion.</li> </ul>
	<ul style="list-style-type: none"> <li>Turn off the power and unplug the line monitor immediately when liquid or foreign substance gets into the line monitor. Continuous use may result in ignition, electric shock and malfunction.</li> </ul>
	<ul style="list-style-type: none"> <li>Do not touch the line monitor with wet hand. This may result in an electric shock and malfunction.</li> </ul>
	<ul style="list-style-type: none"> <li>Do not use the battery other than attached Lithium ion battery. Do not short the electrode of the battery. Do not modify, decompose or heat the battery It may cause the ignition and explosion.</li> </ul>
	<ul style="list-style-type: none"> <li>Do not give a strong impact on the product, such as dropping and crashing.</li> </ul>

 Caution

	<ul style="list-style-type: none"><li>• Do not leave the analyzer in the following conditions.<ul style="list-style-type: none"><li>▪ Strong magnetic field, static electricity or dusty place.</li><li>▪ Temperature and humidity above the specification or where dew condensation appears.</li><li>▪ Not flat, or shaking place.</li><li>▪ Place with leaking water or electricity.</li><li>▪ Place affected by direct sun or near the fire.</li></ul></li></ul> <p> Please do not leave the analyzer in the car during the summer.</p>
	<ul style="list-style-type: none"><li>• Do not use at the following situations. The radio wave by the analyzer may cause trouble.<ul style="list-style-type: none"><li>▪ Near a medical device such as cardiac pacemaker or hearing aid.</li><li>▪ Near an automatic controller such as fire-alarm box or automatic door.</li><li>▪ Near a microwave, high-level electronics, TV, or radio.</li><li>▪ Near a wireless station for mobile communications or a specified low power radio station.</li></ul></li></ul>
	<p>Remove the battery from the analyzer, when you throw away.</p>

 Caution

	<ul style="list-style-type: none"><li>• Please follow the instruction for the USB Battery Charger. It may cause the generation of heat, injure, electric shock and malfunction<ul style="list-style-type: none"><li>▪ Do NOT use it for other than AC 100V to 240V.</li><li>▪ Do no use when it brakes.</li><li>▪ Do not twist or step on the cable of charger. (Do not stress the base of cable.)</li><li>▪ Do not place near the heater or put in the fire.</li><li>▪ Do not disassemble, modify the USB Battery Charger or cable.</li><li>▪ Do not curve the cable around the USB Battery Charger.</li><li>▪ Do not put many loads on one electrical outlet.</li></ul></li></ul>
	<ul style="list-style-type: none"><li>▪ Insert it well to the electrical outlet.</li><li>▪ Remove the dust on the AC plug.</li><li>▪ Unplug the charger if you do not use it.</li><li>▪ When unplugging from the outlet, pull out the body straight.</li></ul>

# CONTENTS

---

---

Instruction.....	1	Chapter 4 SFP Module Information	
Safety Information.....	2	Display Function	45
<b>Chapter 1 Before Using the Product</b>	<b>6</b>	4.1 Connection method .....	45
1.1 Description on This Manual .....	6	4.2 Information display.....	45
1.2 Unpacking .....	6	<b>Chapter 5 Statistic Function</b>	<b>46</b>
1.3 Functions and Feature.....	7	5.1 Connection .....	46
1.4 Name of Each Part.....	9	5.2 Frame Counters.....	46
1.5 Power Supply and Battery.....	13	5.3 Statistical analysis settings .....	46
1.6 Hand Strap.....	15	5.4 Start and Stop Measurement.....	47
1.7 SFP module.....	16	5.5 Display.....	47
<b>Chapter 2 Basic Operation and Set-up</b>	<b>17</b>	<b>Chapter 6 Packet Generator Function</b>	<b>48</b>
2.1 Power Source ON (Opening Screen)	17	6.1 Connection .....	48
2.2 Top Menu .....	18	6.2 Transmission settings .....	48
2.2.1 File Manager .....	19	6.3 Transmission packet summary .....	48
2.2.2 Record Control.....	19	6.4 Editing the transmission packets.....	49
2.2.3 System Config.....	23	6.5 Start and Stop Testing.....	53
2.2.4 Time Settings.....	27	6.6 Test Result .....	53
<b>Chapter 3 Online Monitor Function</b>	<b>28</b>	<b>Chapter 7 Ping Function</b>	<b>54</b>
3.1 Connection .....	28	7.1 Connection.....	54
3.2 Interface Setup .....	29	7.2 Ping Setup .....	54
3.3 Filter Setup.....	30	7.3 Start and Stop Testing.....	55
3.4 Online monitor Configuration .....	34	7.4 Display.....	55
3.5 Start and Stop Measurement.....	36	<b>Chapter 8 Port Blink Function</b>	<b>56</b>
3.6 Display.....	37	8.1 Connection .....	56
3.7 Retrieval Function.....	41	8.2 Searching Hub port.....	56
3.8 Trigger Function.....	43		

Chapter 9 Slice Capture Function 57

9.1 60 bytes of frame data..... 57  
9.2 Slice Capture Settings..... 58  
9.3 Start and Stop Measurement..... 58  
9.4 Test Result ..... 58

Chapter 10 Save and Load of the Data 59

10.1 Storage device ..... 59  
10.2 File Management Function ..... 60

Chapter 11 Utility 66

11.1 Key Emulation Software ..... 66  
11.2 Data Conversion Software ..... 67  
11.3 Capture data files while measuring 69  
11.4 PC Remote Control Library ..... 70

Chapter 12 Printout Function 71

12.1 How to Connect to a Printer ..... 71  
12.2 Hard Copy of Screen Display ..... 71  
12.3 Printout of Measurement Data..... 72

Chapter 13 Specifications and  
Maintenance 73

13.1 Specifications of Function and  
Hardware... 73  
13.2 Shortcut Keys ..... 75  
13.3 Measurable Interface Expansion .... 75  
13.4 Factory reset ..... 76  
13.5 Firmware Update..... 76  
13.6 Trouble shooting..... 77  
13.7 Warranty and After service..... 79

# Chapter 1 Before Using the Product

## 1.1 Description on This Manual

---



### Function for different model



---

- When the performance or function differs depending on the model of the protocol analyzer, [Model number] is described side by side.



### Deception of the Operating Procedure

---

- Printed representation of screen displays in the manual may not be the same as that actually displayed concerning the font and special symbols.
- Descriptions of items of the screen are enclosed in double quotation marks “ ” .
- Reference page is described with .
- Represent key is enclosed in [ ].  
e.g. Press “  ” key. : Press [MENU].
- Successive key or tap operations may be represented by putting their symbols one after another.  
e.g. Press [MENU], then press [0]. : Press [MENU] -> [0].  
e.g. Tap [A], then tap [B]. : Tap [A] -> [B].
- Pressing two keys at the same time is represented by combining their symbols with “+” .  
e.g. Press [SHIFT] and [ESC] at the same time : Press [SHIFT]+[ESC].

## 1.2 Unpacking

---

When you unpack the product, check the items below:

- The product has not been damaged during the transit.
- You have received all the standard accessories listed below.
  - Protocol Analyzer 1
  - Interface Sub-board [SB-10GE] (attached to the analyzer) 1
  - Hand strap ( Already mounted) 1
  - Wide input AC adapter (input: AC100 to 240V, output: DC9V) 1
  - LAN cable 1
  - USB cable (Type A-C) 1
  - External signal I/O cable [LE-4TG] 1
  - Utility CD 1
  - Quick Start Guide 1
  - Carrying bag [LEB-01] 1
  - Warranty 1



The card packed with the product is the user registration card for Japanese customers. For overseas customers, there is a user registration page on our web site.( <https://www.lineeye.com> )

Please let us know if you find any damage to the product or accessories lacking.

- ◆ Utility CD
  - Utility CD contains following files
  - Manual folder : Instruction manual for the analyzer
  - Utility folder : Utility software to convert measurement files to Wireshark format  
Key emulation software

## 1.3 Functions and Feature

---

The LE-8600X/LE-8600XR are equipped with two measurement ports compatible with SFP/SFP+ modules and are handy type Ethernet LAN analyzer that supports high-speed LAN measurement tests that use single-mode or multi-mode optical fiber cables as a single unit. You can log the data automatically to the built-in 500GB SSD. As it has the online monitor function, packet generate (PG) function, statistical analysis function etc. you can use the analyzer according to the test situation. It can be widely used for communication systems, communication device development, inspection, and failure diagnosis.

- ◆ On-line Monitor Function
  - This function records both the Ethernet communication frame flowing through the network and the transmission/reception time (timestamp) of the frame.
- ◆ Statistic Function
  - This is a useful feature for analyzing network traffic and the frequency of specific frames.
- ◆ SFP module information display function
  - You can display the detailed information of SFP/SFP+ modules.
- ◆ Packet Generator(PG) Function
  - You can transmit any packet.
- ◆ Ping Function
  - It is able to confirm the linking to the network by transmitting the Ping commands.
- ◆ Port Blink Function
  - You can see which port on the hub the multiple Ethernet cables are connected to.
- ◆ Slice Capture Function
  - By this function, the analyzer captures only the first 60 bytes of an Ethernet frame.



## Features

---

- Two measurement ports which support SFP/SFP+ modules
- Real-time monitor recording of 10Gbit packets
- Real-time monitor recording of 2.5Gbit packets
- Output test packets for network load test
- Adds time stamps which can be synchronization by GNSS (PPS) signal
- Automatically records communication logs into the internal SSD
- Newly designed lightweight housing with 7-inch color LCD with touch panel
- Save data in PcapNG files that can be analyzed by Wireshark
- PC link with LAN, USB, or Wi-Fi (XR only) connection



## Optional Accessories



---



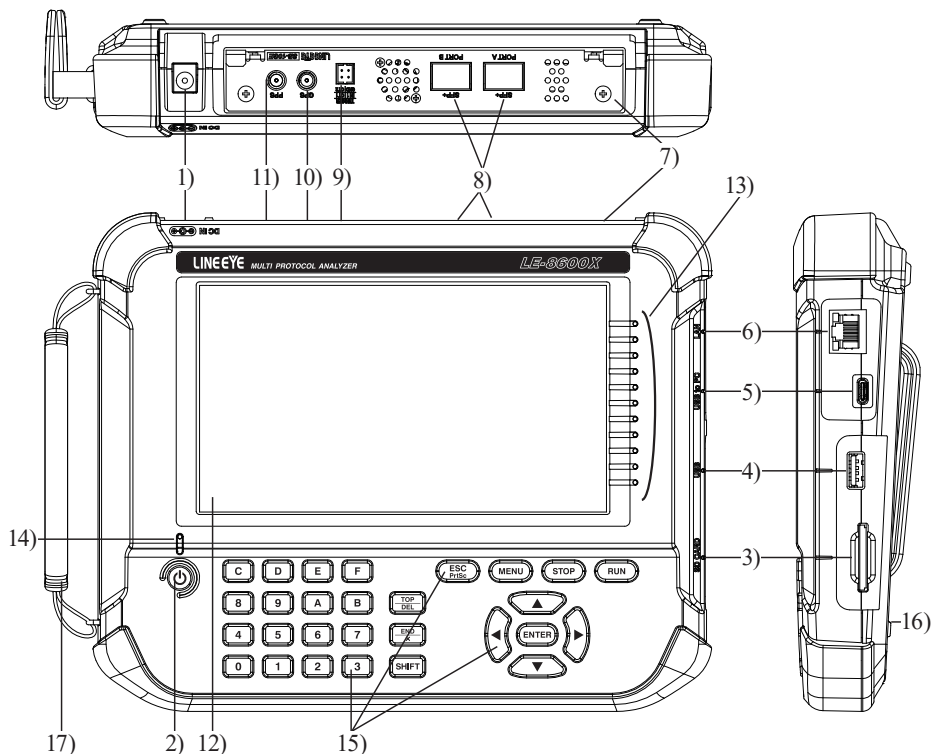

- 1000BASE-T SFP module LE-1G-BT-45
- 1000BASE-SX SFP module LE-1G-SX-85
- 1000BASE-LX/LH SFP module LE-1G-LX-31
- 10GBASE-T SFP+ module LE-10G-BT-45
- 10GBASE-SR SFP+ module LE-10G-SR-85
- 10GBASE-LR SFP+ module LE-10G-LR-31
- 2.5GBASE-T SFP module LE-2G5-BT-45
- Expansion kit for Gbit Ethernet LAN SB-GE2
- Expansion kit for RS-232C/530/422/485/TTL communication SB-R2TS1
- Zero-latency LAN/PoE (2ch) measurement expansion kit SB-FE2
- Single-pair Ethernet communication expansion kit SB-T1E
- CAN/high-speed analog measurement expansion kit SB-C2AN
- GPS active antenna EB-SL-AA170
- Coaxial cable for PPS synchronization LE-SMA-MM-2
- LAN cable
- Lithium ion battery pac P-26LW2
- 8Gbyte SDHC card SD-8GX
- 16Gbyte SDHC card SD-16GX
- 32Gbyte SDHC card SD-32GX
- Portable thermal printer SM4-31W

## 1.4 Name of Each Part

### General



Name	Description
1) AC adapter plug	Connects the AC adapter, which serves as a battery charger.
2) Power Switch	Press for about 1 second to turn the power on/off.
3) SD Card Slot	The inlet for a SD/SDHC card.
4) USB Host Port	Connection port for a USB flash drive or Printer.
5) USB Device Port	USB Type-C connector connected to a PC or battery charger.
6) Wired LAN	Connect to a computer via Ethernet LAN. The right LED lights in green when linking. The left LED lights in orange when 1000BASE-T is connected.
7) Interface Sub-Board	The interface sub-board (SB-10GE) for measuring of 10GbE is inserted. Able to exchange to the optional interface sub-boards.
8) PORT A,B	Insert SFP/SFP+ modules for various measurement.  1.7 SFP module
9) External Input Terminal	Input/output terminal for TTL level external signal.  3.8 Trigger Function EXT TRG Enable

10)	GPS antenna connector	SMA (female) connector for an active GPS antenna connection. A GPS antenna is to be connected.  2.2.4 Time Settings  3.4 Online monitor Configuration Timestamp synchronization
11)	PPS signal connector	SMA (female) connector for PPS signal input/output. Used for the PPS time synchronization function.  3.4 Online monitor Configuration Timestamp synchronization
12)	7 Inch Color Display	7 Inch Color Display with capacitive touch panel.
13)	Line State LED	Displays the status of the interface to be measured.
14)	Power LED	Lights in green when the power is turned on. Blinking in red when charging battery.
15)	Keypad	Entering commands and other operation.
16)	Battery Cover	Open/close when replacing the battery.  1.5 Power Supply and Battery
17)	Hand Strap	Use to hold the product.

## LED and Display

### ■ Power LED

Light in green during operation. Blink in red while it charges a battery.

Slow charge (when AC adapter is connected) : Blink per 1 sec.

Normal charge (when connected by USB Type-C) : Blink per 1.5 sec.

Fast charge (when connected via other USB) : Blink per 4 sec.

 1.5 Power Supply and Battery

### ■ Line state LED

Tap “LED” at the bottom right of the screen to display the meaning of each LED.

If you tap anywhere in the area while it is displayed, it will be hidden.

You can also switch shown/hidden the display of the meaning of each LED by pressing [SHIFT] + [MENU].



SFP A 10G*	An SFP module that supports 10GbE is inserted into the A port.
SFP A 2.5G	An SFP module that supports 2.5GbE is inserted into the A port.
SFP A 1G*	An SFP module that supports 1GbE is inserted into the A port.
<u>    </u> A LOS*	The Rx Loss Of Signal of A port is not on. Slowly blinks when there is a warning in the SFP diagnostic information on the A port.
A warning	Blinks in high speed when there is an alarm in the SFP diagnostic information on the A port.
SFP B 10G*	An SFP module that supports 10GbE is inserted into the B port.
SFP B 2.5G	An SFP module that supports 2.5GbE is inserted into the B port.
SFP B 1G*	An SFP module that supports 1GbE is inserted into the B port.
B LOS*	The Rx Loss Of Signal of B port is not on Slowly blinks when there is a warning in the SFP diagnostic information on the B port.
B warning	Blinks in high speed when there is an alarm in the SFP diagnostic information on the B port.

\* Depending on the specifications of the SFP module, the LED may not light correctly.

 The meaning of the display state changes depending on the interface board.

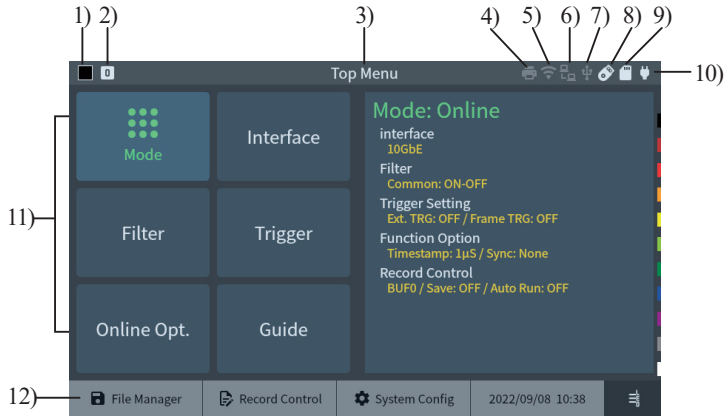
■ Data display window





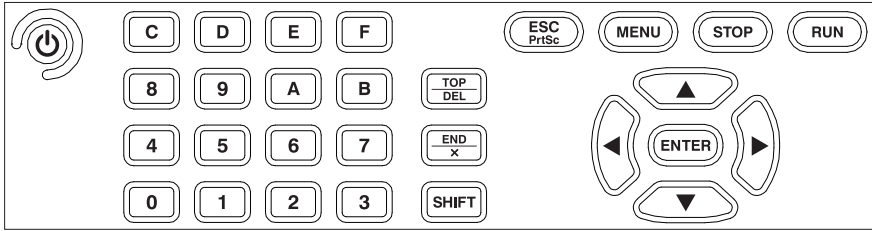

1)	Measuring “●”, Pause “■”
2)	Currently valid capture buffer.  2.2.2 Record Control Recording area
3)	Description of the current window.
4)	USB printer status (bright display when connecting )
5)	Wi-Fi status (bright display when IP address is acquired or access point is ready)  Not displayed on models that do not support Wi-Fi.
6)	Wired LAN status (bright display when IP address is obtained)
7)	Status of USB device port. (Connected when the color is bright, “🖨️” is displayed when it is in super speed.)
8)	Status of USB host port. (Bright color when recognizing, red when writing)
9)	Status of SD card slot. (Bright color when recognizing, red when writing)
10)	Estimated battery level is displayed, and “🔋” is displayed when power is supplied from the outside.
11)	Setting items or measured data.
12)	Touch panel for advanced settings.

## Key operation

There is a keyboard to input data and operate commands.



### ■ Keys

Operations	Function
[  ]	Turn ON/OFF the power. Press it for more than 1sec.
[RUN]	Start monitoring, measuring or testing operation.
[STOP]	Stop monitoring, measuring or testing operation.
[MENU]	Return to the top menu.
[ESC]	Return to the previous display Return to the data display from configuration.
[  ], [  ]	Scroll one data line. Move the cursor on the condition setting.
[  ], [  ]	Scroll one character of data. Change the setting on the condition setting.
[ENTER]	Apply selected settings.
[0]~[F]	Enter numerical values.
[TOP/DEL]	Delete the entry indicated by the cursor.
[END/X]	Enter the data of "Don't Care".
[SHIFT]	Press to use the expanded alternate function of each key.
[SHIFT]+[TOP/DEL]	Jump to the top of data.
[SHIFT]+[END/X]	Jump to the end of the screen.
[SHIFT]+[ESC]	Save the screen image. / Hardware copy.
[SHIFT]+[MENU]	Display/hide the description of LEDs.
[SHIFT]+[RUN]	Brighter the LCD back light.
[SHIFT]+[STOP]	Darker the LCD back light.

\* [X]+[Y] indicates the operation of pressing [X] and [Y] together at the same time.

 Shortcut keys are available from [MENU] and [0]~[F].

 13.2 Shortcut Keys

- Touch panel

Following operation is available.

Tap	Tap the screen once to select the setting etc.
Double tap	Tap the screen twice to select and execute the setting.
Swipe	Touch and slide the finger to scroll data.

## 1.5 Power Supply and Battery

This analyzer runs by attached AC adapter, or built-in rechargeable battery.

- Charge the Battery

The built-in lithium-ion battery is charged when powered by the AC adapter or bus-powered from the USB device port.



The charging time will be as follows depending on the usage conditions.

Power supply	Analyzer	Status	Charge Time	Power LED blinking
AC adapter	OFF	—	About 3.5 hours	Approx.1sec cycle
	ON	Stop measuring	Max. 6 hours <sup>*1</sup>	Approx.4sec cycle
		Measuring	No charge	No charge
USB bus power	OFF	Use attached USB cable	Max. 6 hours <sup>*1</sup>	Approx. 4 sec cycle
		Use Type-C battery charger etc. <sup>*2</sup>	About 4.5 hours	Approx.1.5 sec cycle
	ON	—	No charge	No blinking

\*1 : This will not be full charging because of the small amount of current (approx. 160mA).

\*2 : It will be the same when it connects to the PC with a USB port in Type-C connector.

- ☞ This analyzer is not charged in full before shipping. To use the analyzer at the first time, charge it full.
- ☞ Charge the analyzer under the temperature of 5 to 40 °C. It will not start charging below 5 °C.
- ☞ If you are not going to use it for a long term, charge the battery in full. After that, try to charge the battery every 6 months.

- Replace the Lithium ion battery

If the analyzer can no longer drive by the battery, or the service time after charging becomes extremely short, replace the battery.

Disconnect the cables, turn off the analyzer, remove the battery cover, and replace the old battery.

📄 As batteries are consumables, the replacement of a battery will cost you even during the warranty period.

📄 Old battery has to be handled in an appropriate manner.



13.7 Warranty and After service

To replace the battery, purchase LINEEYE Lithium ion battery pack (model: P-26LW2), and do not use any other.

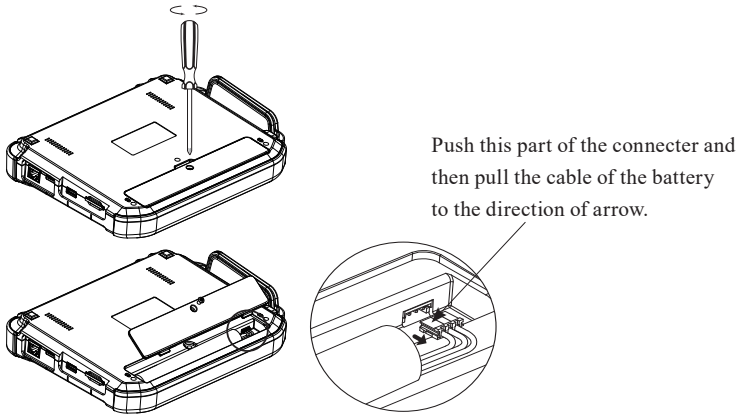

📄 The battery is necessary for protection in the event of a sudden power failure, so be sure to install and use it.

- Lithium primary battery

The clock built into the unit is backed up by the built-in lithium primary battery for about 5 years even when the power is turned off.

📄 If the watch goes wrong or will be reset, replacement of the lithium primary battery at our factory is required. In that case please contact LINEEYE or LINEEYE distributor.

## 1.6 Hand Strap

---

You are able to put and remove this hand strap.



### Put on the hand strap

---

Hand strap is already set in the analyzer when you purchase.

<Remove the hand strap>

- 1) Open the Velcro.
- 2) Remove the belt.
- 3) Remove the hand strap from the analyzer

 Reverse the process when putting on the hand strap.

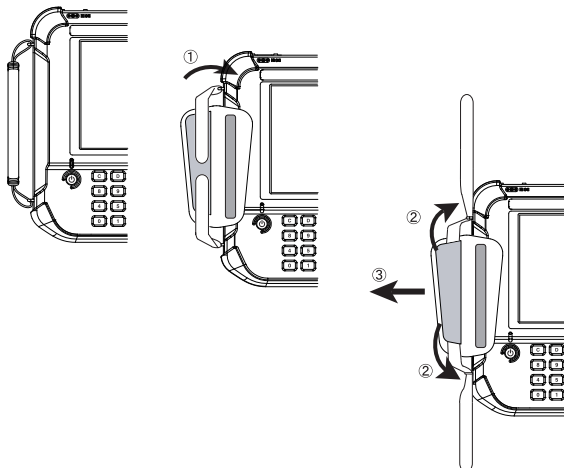

### NOTICE

Put each magic tapes of the belt in the hand strap for 3cm or more.

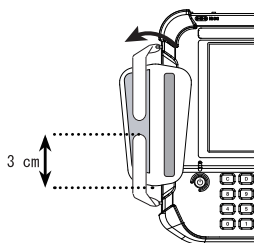

## 1.7 SFP module

SFP modules (sold separately) must be installed in order to perform measurements with this unit. We have the following as optional items.

Type	Model	
1000BASE-SX SFP module	LE-1G-SX-85	Wave length: 850nm, maximum transfer distance: 550m (LC)
1000BASE-LX/LH SFP module	LE-1G-LX-31	Wave length: 1310nm, maximum transfer distance: 20km (LC)
1000BASE-T SFP module	LE-1G-BT-45	Maximum transfer distance: 100m (RJ45)
10GBASE-SR SFP+ module	LE-10G-SR-85	Wave length: 850nm, maximum transfer distance: 300m (LC)
10GBASE-LR SFP+ module	LE-10G-LR-31	Wave length: 1310nm, maximum transfer distance: 10km (LC)
10GBASE-T SFP+ module	LE-10G-BT-45	Maximum transfer distance: 30m (RJ45)
2.5GBASE-T SFP module	LE-2G5-BT-45	Maximum transfer distance: 30m (RJ45)

### ■ Installing an SFP module

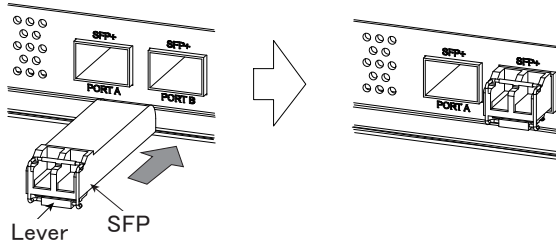

Firmly insert the SFP module as far as it will go.



Chapter 4 SFP Module Information Display Function

### ■ Remove the SFP module

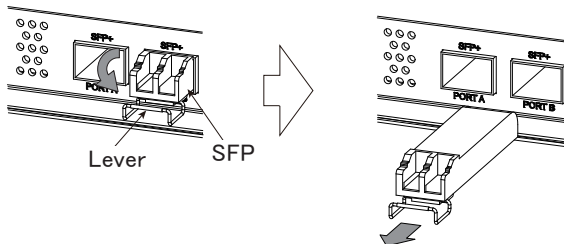

Keep in mind that the lever is down when you remove the SFP module.



- Some SFP modules may become hot during use. Be careful not to burn yourself when removing.
- Use the SFP module of the same speed set on the Interface screen.  3.2 Interface Setup
- Do not connect or disconnect the SFP module during measurement. It cannot capture data correctly.
- Please note that correct operation using SFP modules other than our optional products is not supported.

# Chapter 2 Basic Operation and Set-up

## 2.1 Power Source ON (Opening Screen)

### Power Source ON

Press [  ] for about 1 second to start and display the opening screen. It takes about 15 seconds to start. At the first boot, the Japanese-English display language selection screen will be displayed. When it is already set, the top menu screen will be displayed.



Both LE-8600XR and LE-8600X models are displayed as “LE-8600X”.

### Language (English or Japanese)

At the first boot, you can switch the display language between Japanese and English. To change the already set one, set it at “Language” in the system settings from the top menu screen.

#### 2.2.3 System Config Language

This setting is valid until the system is initialized or the system is recovered from the firmware update operation.

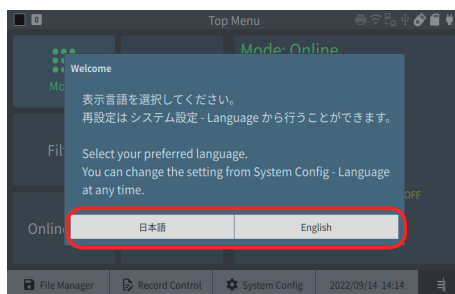

 13.4 Factory reset

 13.5 Firmware Update

### Power Source OFF

Press and hold the power switch for about 1 second to turn off the power of the analyzer. The setting data and captured data are saved in the inner memory of the analyzer for about 16M bytes but not all the measured data cannot be saved. Save the data that you want to keep to the internal SSD or to a storage device such as an SD card before turning off the power.

 2.2.2 Record Control

## 2.2 Top Menu

Press [MENU] to set the initial settings.

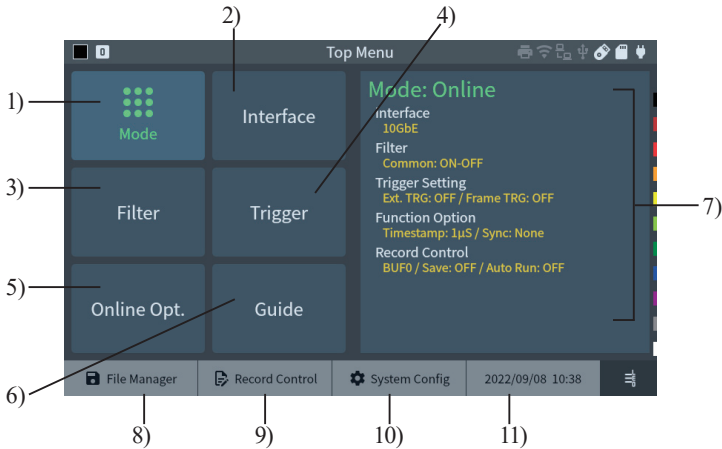









Touch the setting item, or press [ENTER] after selecting the item by [ ▲ ] [ ▼ ] [ ◀ ] [ ▶ ]

Press [ESC] to move to the measurement result display screen.

To switch the measurement mode, tap “Mode” or press [ENTER] while selecting “Mode” and select from the displayed mode list.

You can call up each setting screen by touching “File manager”, “Record Control”, “System Config”, and the current time display at the bottom of the top menu screen.

1)	Switch the measurement mode.	
2)	Set the interface.	 3.2 Interface Setup
3)	Set the filter for online monitor mode.	 3.4 Online monitor Configuration
4)	Set the trigger for online monitor mode.	 3.8 Trigger Setup
5)	Set options for online monitor mode.	 3.4 Online monitor Configuration
6)	Display the operation guide.	
7)	Displays the currently set measurement mode setting. You can also tap this part to move to the setting change screen.	
8)	Save/read to a file.	 2.2.1 File Manager
9)	Configure settings related to the capture buffer for recording measurement data and the save destination.	 2.2.2 Record Control
10)	Configure settings related to screen brightness, network, language, firmware update, etc.	 2.2.3 System Config
11)	Set the time.	 2.2.4 Time Settings

## 2.2.1 File Manager

Save/read to a file.

 Chapter 10 Save and Load of the Data

## 2.2.2 Record Control

Make settings related to the capture buffer for recording measurement data and the save destination.

### ■ Dividing a Capture Buffer

Tap the tab of “Capt. Buffer” and set the capture memory setting of recorded data.

#### ◆ Recording area

The capture memory is 1024 Mbytes.

Select whether a memory is used as one capture buffer or two capture buffers.

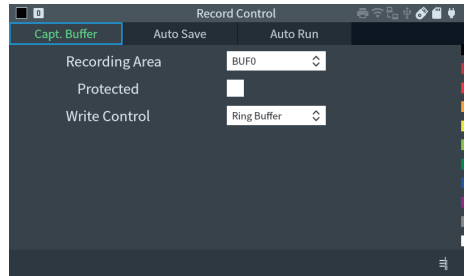

BUF 0 : The whole buffer can be used as one capture buffer.

BUF 1/2 : The capture buffer is divided into two (BUF1 and BUF2) and they are used to measure separate data.

Select when comparing measurement data.

#### ◆ Protected

Mark on the box to prevent data recorded in the buffer memory from being inadvertently overwritten.

 Do not mark on the box when it uses Auto-save function.

#### ◆ Write Control

Select the recording type of capture memory.

Ring Buffer :

When the capture memory is used up, the data is overwritten from the beginning of the memory and the communication data is recorded endlessly.

Full Stop :

When the data is recorded to the end of the capture memory, the measurement is automatically stopped.

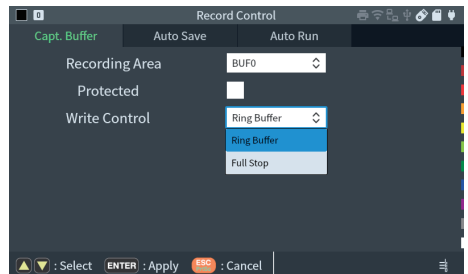

## ■ Auto Save Function

Touch the Auto Save tab to set auto save settings and auto backup settings. By using the auto save setting, the contents of the capture memory which is used for monitoring can be automatically saved continuously for a long time as a measurement log file (auto save file) of a specified size to the built-in SSD or to a storage device such as an SD card. As you can check the auto-save file which is automatically saved during the communication failure occurrence time by the file management function, it is useful for clarifying communication failures of unknown cause that occur rarely. In addition, as the capture memory loses data when the power is turned off, the latest 16Mbytes of measurement data is automatically backed up to the built-in eMMC at the end of measurement. If you want to automatically save the entire measurement data or delete the data when you turn off the power, change the setting of the auto backup function.

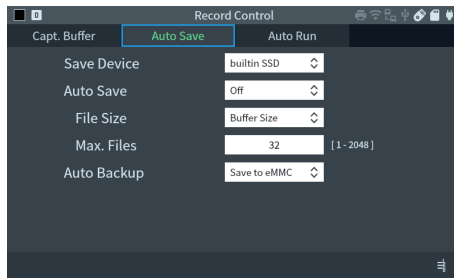

## ● Preparation and settings

When recording to an external storage device, set the device with an appropriate capacity according to the time you want to record continuously.

If the speed of writing to a storage device is relatively slow to the amount of data to be stored, the writing will not be in time and log data will be lost.

### ◆ Save Device

Specify the built-in SSD, SD card, or USB memory inserted in the unit.

### ◆ Auto Save

Set the condition of the auto save function.

Off : Auto save function does not work

Restart : Continuous ring recording of auto-save files within the maximum number of files

Max-stop : Saves up to the specified number of auto save files and stops measurement

Append : Continuous ring recording from the file number next to the existing auto save file number

📄 The name of the auto-save file which is automatically saved is #XXXXXXX.DT (XXXXXXX is a sequential number that increases by 1 from 0000000)



- If you set “Restart” or “Max-Stop”, all existing auto save files will be deleted at the start of measurement
- When saving the measurement log for a long time with the auto save function, set the main unit capture memory to the ring buffer. Also, make sure that the trigger condition that stops the measurement is not set.



2.2.2 Record Control Write Control



3.8 Trigger Setup

#### ◆ File Size

Specify the file size of the auto save file from 4M, 16M, 64M, 256Mbytes or “Buffer size” . The “Buffer size” will be the same as the capture memory size. Max files

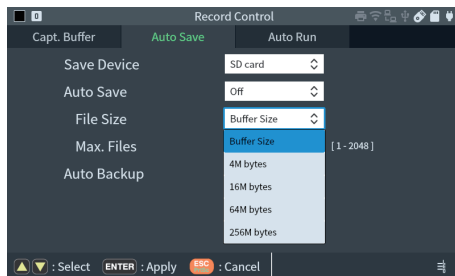

#### ◆ Max. Files

Set the maximum number of auto save files to be automatically saved.

Even if the storage device has free space, it may not be able to store the specified maximum number of files due to media limitations.

#### ◆ Auto Backup

Specify the destination to save the automatic backup data.

The initial value is “Save to eMMC”

Off :

It does not execute automatic backup. Select this when you do not want to keep the measurement data after turning off the power.

Save to eMMC :

Saves the latest 16M bytes of measurement data to the built-in eMMC.

Save to File :

The entire buffer when a measurement is stopped is saved in the storage device specified in “Save Device”.

When “Save to eMMC” is set, the measurement data saved in eMMC is automatically loaded to the capture memory when the power is turned on.

When “Save to File” is set, all measurement data will be saved to a file named @AUTOBU<sub>n</sub>.DAT (n is the number of the used capture memory BUF0, BUF1 and BUF2). Load it manually to use it.

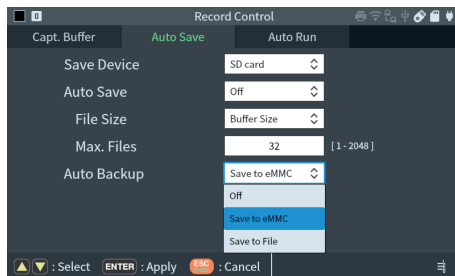

10.2 File Management Function

- Auto Run Function

By using this function, you can repeat the measurement automatically for the specified period by specifying the date and time when the measurement starts and ends. It can start the measurement in conjunction with power-on and automatically finish the measurement at the specified date and time.

- ◆ Auto Run mode

Select the measurement repetition period from Monthly (run monthly), Daily (run daily), or Hourly (run hourly).

- ◆ Run time

Set the date and time when to start the measurement according to the mode. It becomes effective when checked.

- ◆ Stop time

Set the date and time when to finish the measurement according to the mode. It becomes effective when checked.

- ◆ Standby power off

Set whether to enable the function to turn off the power while waiting for the measurement to start. If checked, the power will be turned off automatically after 10 seconds passes if there will be more than 5 minutes between the time when it is turned into the automatic measurement standby state and the start of the next measurement. After that, 3 minutes before the start of measurement, the power is automatically turned on and it is turned into the measurement standby state.

- ◆ Checking the power supply status

Set whether to enable the function to check the power supply from the outside at the start of measurement. When checked, if there is no external power supply when the measurement start time comes the measurement will not start and will remain in the standby state. If “Power off standby” is enabled at the time of this standby state, the power will be turned off automatically after 10 seconds passes.

- ◆ External power on Run

When checked, measurement will start 10 seconds after the power is supplied by the AC adapter. It is used when you want to start measurement in conjunction with the turning on by the external power.

- Control

When “Run Time” is checked, after pressing [RUN] it turns to be wait status until the specified time arrives. To cancel the waiting status press [STOP] or tap “Cancel”.

When the specified time comes, the measurement starts automatically. When the “Stop Time” is checked, the measurement is performed up to the specified time and the measurement automatically stops. This measurement process will be executed repeatedly according to the condition set at “Mode”.

When “External power on Run” is checked, when the power supply by the AC adapter is started while the power of this unit is off, the power will be automatically turned on, and 10 seconds after the boot is completed, the measurement starts automatically without pressing [RUN].

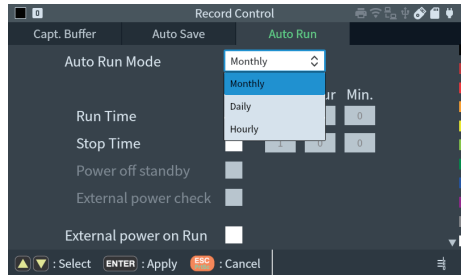
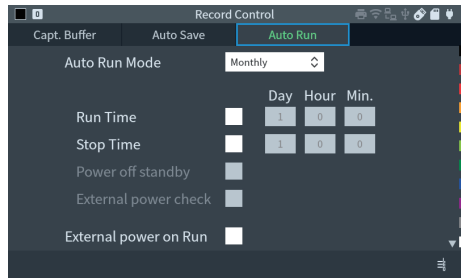

## 2.2.3 System Config

### ■ Display / Power

#### ◆ Backlight brightness

Adjust the brightness of the backlight.

The brighter the backlight, the shorter the running time (higher consumption of current).

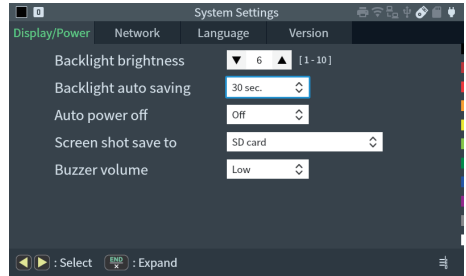

☰ You can also adjust the brightness of the backlight with [SHIFT] + [RUN] (bright) or [SHIFT] + [STOP] (dark). Use this operation when you want to change the brightness during measurement.

#### ◆ Backlight auto saving

Set the automatic backlight dimming time. If no operation is performed within the set time (15 seconds to 30 minutes), the backlight will be automatically darker to save power consumption. Set “Off” to invalidate this setting.

#### ◆ Auto Power Off

If no operation is performed for the set time (5 minutes to 60 minutes), the power will be automatically turned off to reduce unnecessary power consumption. Initial setting is “Off”.

☰ While measuring data, auto-power off function will not work.

#### ◆ Screen shot save to

The screenshot of the display is saved to the connected external storage device. When both types of storage devices are connected, it is saved to the one specified in this setting.

When you select “USB printer” or “WLAN printer”, it will be hard-copied from the printer.

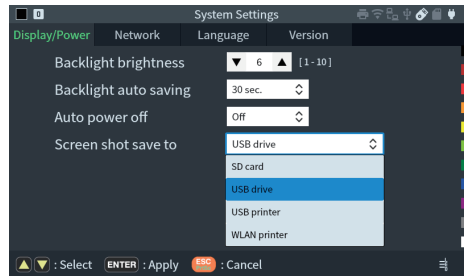

📖 Chapter 12 Printout Function

#### ◆ Buzzer Volume

Select the volume of the buzzer sound when triggered by the trigger function from “Low” or “High”.

📖 3.8 Trigger Function

☰ While measuring data, auto-power off function will not work.

## ■ Network

At the time of shipment, the built-in Wi-Fi module is disabled and no wireless radio waves are output. When connecting to a computer remotely via wireless LAN, you need to set up a Wi-Fi connection.

 The Wi-Fi function is not available for LE-8600X.

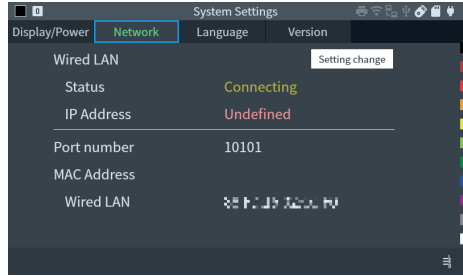

### ◆ Wired LAN

Status            Displays the status of the wired LAN connection.

IP address        Displays the IP address of this unit connected to a wired Ethernet LAN.

Tap “Setting change” to display the setting change screen.

#### • Port number

Set the port number of the analyzer. The port number is common to Wi-Fi connections. The initial value is “10101”.

#### • DHCP

Mark on the box when using the network which provides the IP address automatically. Remove the mark if using the specific IP address.

#### • IP Address

IP Address of the analyzer.

#### • Subnet mask

Subnet mask of the analyzer.

#### • Default gateway

Set the default gateway of this device.

#### • DNS server

Set the address of the DNS server.

### ◆ Wi-Fi connection

Status            Displays the status of the Wi-Fi connection.

IP Address        Displays the IP address of this device connected to Wi-Fi.

Tap “Setting change” to display the setting change screen.

#### • Port number

Set the port number of analyzer. The initial value is “10101”.

#### • Mode

Set the Wi-Fi connection method.

Off                The inner Wi-Fi module is invalid.

Station            The analyzer connects to the network via wireless access point.

Access Point      The analyzer itself becomes the wireless access point, and connects to the PC one by one.

## ○ Station Mode

- Port number  
Set the port number of analyzer. The initial value is “10101” .
- SSID  
SSID of wireless access point.
- Password  
Security key (encryption key) of wireless access point.  
 Input characters are changed to “●” for security purpose.
- DHCP  
Mark on the box when using the network which provides the IP address automatically. Remove the mark if using the specific IP address.
- IP Address  
IP address of the analyzer.
- Subnet mask  
Subnet mask of the analyzer.
- Default gateway  
Set the default gateway of this device.
- DNS server  
Set the address of the DNS server.

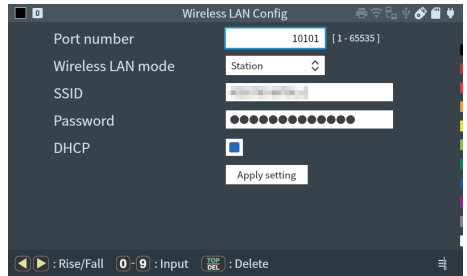

Before changing the IP address and DHCP, try to confirm with the person who is in charge of the network.

Tap “Apply setting” at the end. If the analyzer can connect to the wireless access point successfully, following display will be appeared.

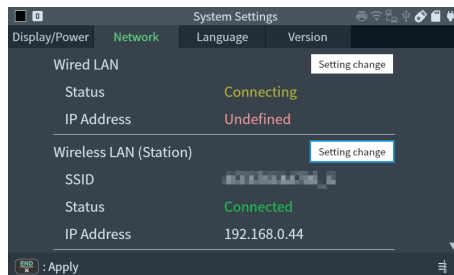

-  If the connection fails, try near a Wi-Fi access point.  
Also, double-check the SSID and password of the Wi-Fi access point.

○ Access point mode

Tap “Apply setting” at the end.

- Port number  
Set the port number of analyzer. The initial value is “10101” .
- Security  
Select the security protocol from OPEN, WPA, WPA2 or WPA/WPA2.  
 If selecting “OPEN” , the password will be invalid.
- SSID  
The initial value is “LE\_XXXXXXXX” . (XXXXXXXX is the serial number)  
If using more than one analyzers, each one should have different SSID.
- Password  
Security key (encryption key) of wireless access point.  
The initial value is “@XXXXXXXX#” . (XXXXXXXX is the serial number)
- Channel  
Select the wireless channel (1~11). If selected channel is crowded, try to use another channel.

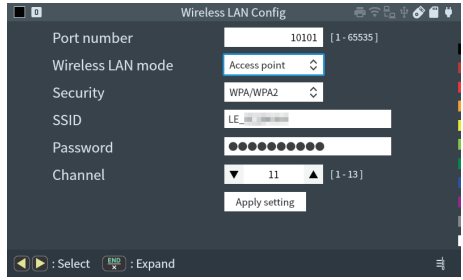

When the wireless access point is set, the status display will be “Active”.

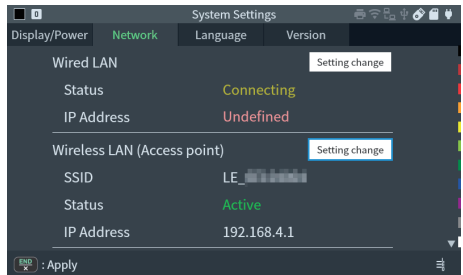

For access point mode, the IP address of analyzer is “192.168.4.1” and this cannot be changed. This , change the IP address of the target device (PC etc.) to the one within the same network group (exp. 192.0.168.4.2), or change the setting of the DHCP server to receive the IP address from analyzer.

■ Language

Select a language (English or Japanese).

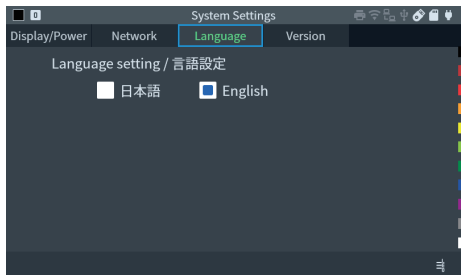

- Version

It displays the current firmware version of the analyzer, executes the firmware update mode, and initializes the main unit.

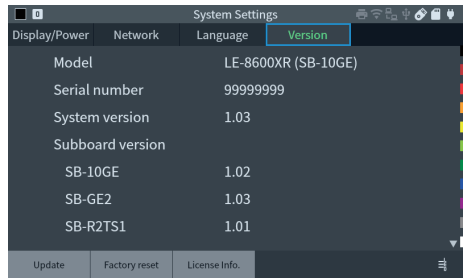

13.5 Firmware Update

13.4 Factory reset

## 2.2.4 Time Settings

---

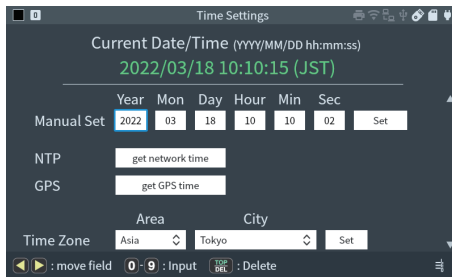

Current time and date are displayed in the screen.

Set the time in order of Hr(24hour)/Min/Sec, and date in order of Yr/Mon/Day.

- Manual Set

Manually set the date and time. Use [ ◀ ] [ ▶ ] to move the cursor, use [0] to [9] to enter, and press “Set” to confirm.

- NTP

Set the current time using an NTP server on the Internet. You need to set the network settings so that it can use Internet communication.

2.2.3 System Config Network

- GPS

Set the current time using GPS. The GPS antenna must be connected. When the setting fails, move the antenna to a location with good reception, then wait a while, and try again.

- Time Zone

Specify the time zone.

Information of time and date is used for time stamp and Auto start/stop. Make sure to input the current time and date precisely.

# Chapter 3 Online Monitor Function

Online monitor function is to capture LAN frames passing over a network along with time stamp information of the frame and record it into the Buffer memory.

Touch “Mode” on the top menu screen and select “Online” on the mode selection screen.

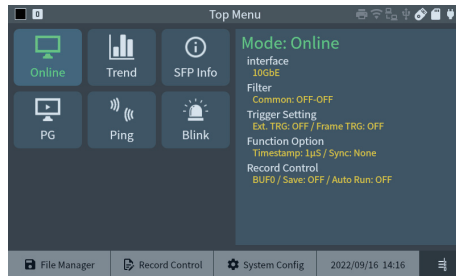

## 3.1 Connection

Connect the cable (through which data flows between the devices) to the SFP module of each port as shown below.

For branch connections, use cables that match the communication you want to measure.

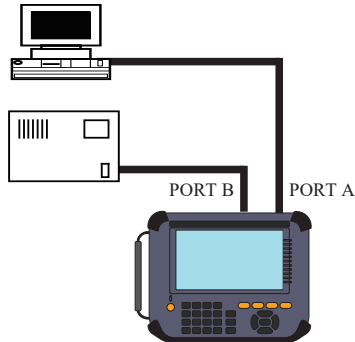

When it is in online-monitoring, it will be as shown in the figure below.

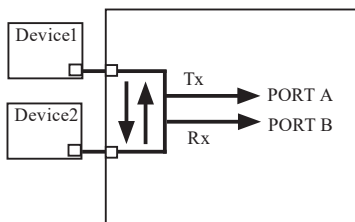

Tx between TAP A and B is recorded as PORT A, Rx is recorded as PORT B.

In TAP mode, the analyzer once receives packets from Port A and Port B, captures them, and sends packets to the opposite port.

A delay occurs when passing through the TAP circuit of this unit.

Depending on the SFP module used, you will likely see a delay of less than 1 microsecond.

## 3.2 Interface Setup

---

After selecting the measurement mode from the top menu, tap “Interface” and set the interface type to be measured on the interface screen.

- **Speed**  
Displays the currently set speed.
- **Switch Speed**  
Switch to the specified speed. Since a restart is required to switch the speed, if you operate it, it will shut down after a confirmation screen.

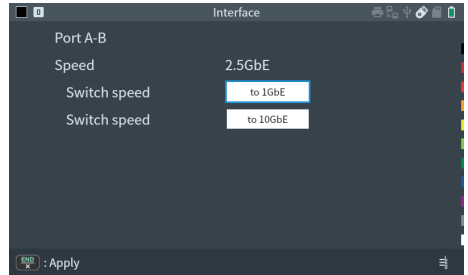

NOTICE	• Use the SFP module of the same speed set on the Interface screen.
--------	---

## 3.3 Filter Setup

From the online monitor mode screen, tap “Filter” to set the filter conditions for capturing only specific frames. Filters can also be set individually for Tx and Rx.

Two filters can be set.

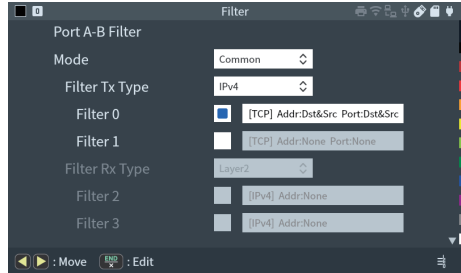

- Mode

Select the filter configuration mode for Rx (only Tx side filter has the setting.).

Common : Applies the configuration of Tx.

Separate : Applies the configuration of Rx.

 The configuration for Rx is available when you select Separate.

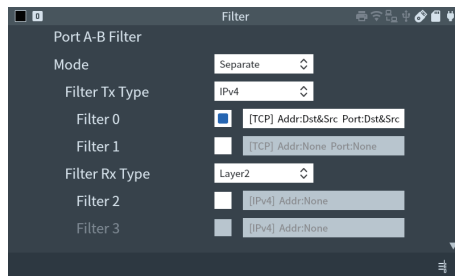

- Type

Select the filter type.

Layer2 : Layer 2 field

IPv4 : IP(Version4) field

- Filter

Select valid/invalid of the filter.

 When the filter of smaller number is No effect the filter of larger number also turns to be No effect.

e.g. ) When the filter 0 is No effect, the filter 1 also turns to be No effect.

## <IPv4>

Set the conditions of IP header for IPv4 frame.

### ■ Protocol Field

Select the protocol field from ICMP, IGMP, TCP, UDP, Custom (specify the number) and All.

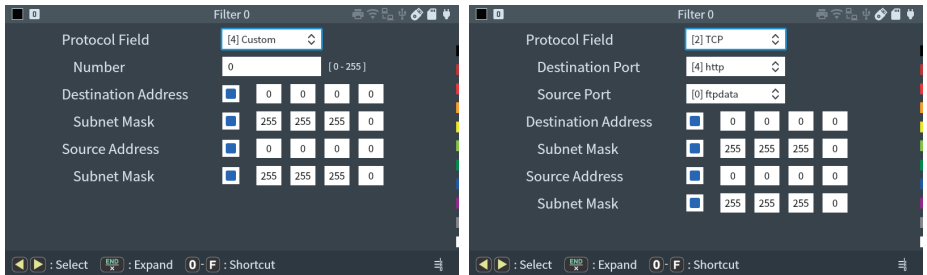

### ■ Number

Input the protocol number, in the case of the selecting “ Custom ” at “ Protocol field ” .

### ■ Destination Port

Input the destination port number when TCP or UDP is selected in the Protocol field.

### ■ Source Port

Input the source port number when TCP or UDP is selected in the Protocol field.

 If the option is added to the IP header of the frame, the function of “source Port” and “Destination Port” will not work properly.

### ■ Destination Address

If checked, you can specify the destination (Dst) address.

### ■ Source Address

If checked, you can specify the destination (Src) address.

### ■ Subnet Mask

You can specify it by checking it.

The target range is the network address obtained from the bitwise AND of this value and the destination (Dst) and destination (Src) address specified values.

<Layer2>

Set the conditions of MAC header for target frame.

- Type Field  
Select the type field from IPv4, ARP, NetBios, IPv6, EtherCAT, Custom (number specified), ALL (not specified).
- Number  
Input the type number, in the case of the selecting “Custom” at “Type field” .
- Destination Address  
If checked, you can specify the destination (Dst) address.
- Source Address  
If checked, you can specify the source (Src) address.

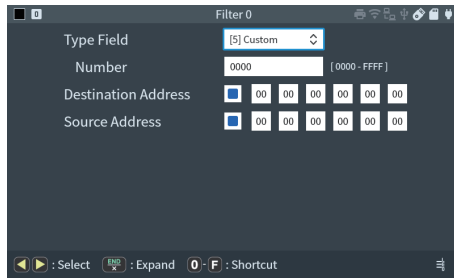

<Example of IPv4 setting>

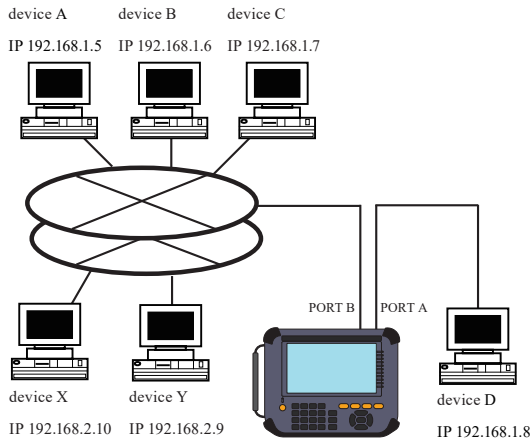

- Monitoring example of TCP/IP frames between Device A and D by filtering.

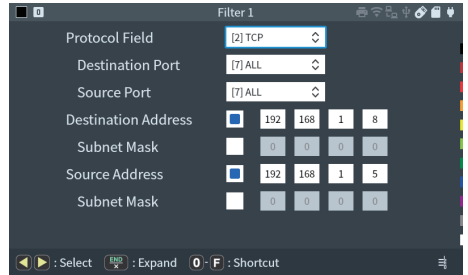
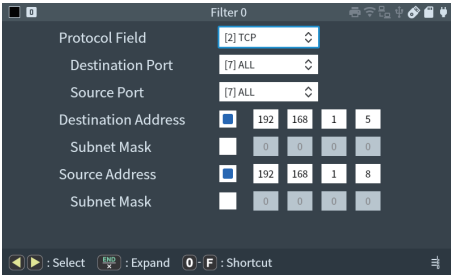
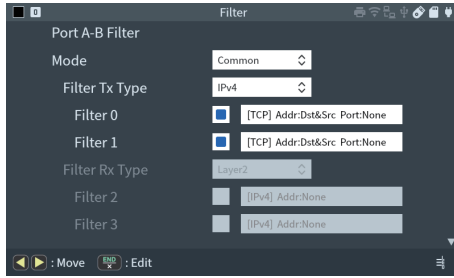

The filter 0 is configured to monitor TCP frames sent from the device D to device A and the filter 1 is configured to monitor TCP frames sent from the device A to device D. Configures this setting between port A-B.

- An example of the configuration to monitor only the UDP protocol communication between the devices X and Y which belong to the network address “192.168.1”

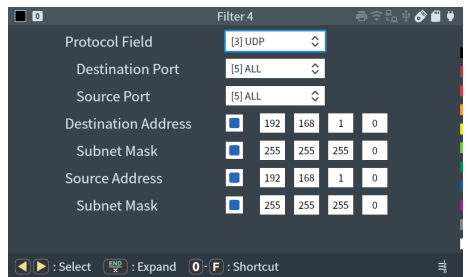
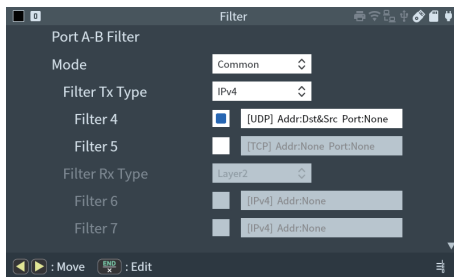

It is configured by filter 4 to monitor only the frames of UDP protocol which have “192.168.1” for the network address part of both source IP and destination IP.

## 3.4 Online monitor Configuration

From the online monitor mode screen, tap “Online Opt.” to enter the settings screen for data recording.

### ■ Timestamp Resolution

Records the time when the packet is received. Select the resolution from 10us/1us/8ns. When you execute a long-term measurements, the internal 46-bit counter may go around with the minimum resolution setting. In that case, set the resolution coarsely.

[ Maximum measurement time ]

8ns : about 6.5 days

1us : about 2.2 years

10us : about 22 years

### ■ Synchronization

Set when synchronizing the time stamp to a certain condition.

None      Uses the built-in RTC of analyzer

GPS time      Synchronize with PPS signal obtained from GPS

Ext. PPS      Synchronizes with the PPS signal input from the PPS terminal

📄 When either synchronization is enabled, it takes 3 to 4 seconds to actually start the measurement because the synchronization work starts at the start of the measurement. If a valid PPS signal cannot be received during that time, an error will occur and the measurement will not start. Be especially careful when using the automatic measurement function.

📄 For external PPS synchronization, the measurement start time is the positive second (○○ seconds .000000000) closest to the current internal clock time.

If you want to synchronize the data time stamp with UTC as well as the relative time after the start of measurement, you need to set the built-in clock to an error of less than 0.5 seconds in advance using NTP etc.

### ■ Invert PPS polarity

When not checked, the time will be adjusted by detecting the falling edge. Do not check when the PPS signal is output by another LE-8600X/LE-8500 series or a PPS signal output device that outputs the time at the falling edge.

Check this when using a PPS signal output device that outputs the time at the rising edge.

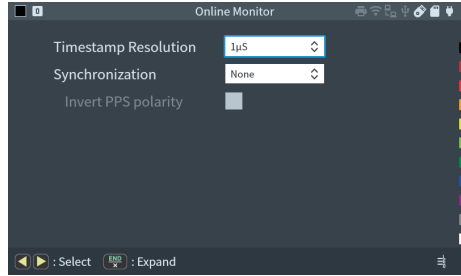

< About connection and setting of time stamp synchronization function >

The timestamp synchronization feature has the following connections.

- Synchronize by GPS antenna

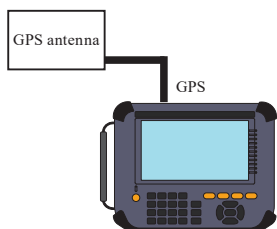

Synchronizes the LE-8600X's time stamp using a GPS active antenna. Then optional GPS active antenna is needed.

Set "GPS time" to "Synchronization" on LE-8600X.

- Share GPS antenna with two units

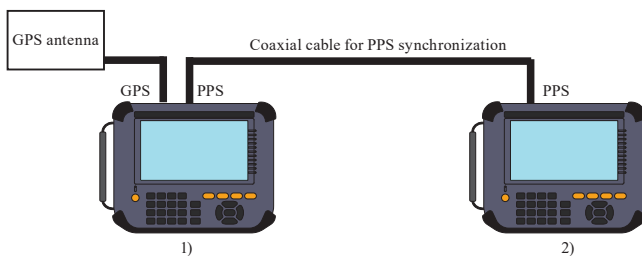

Synchronizes the time stamps of two LE-8600Xs with one GPS active antenna. Optional GPS active antenna and PPS cable are needed.

For LE-8600X 1), set "GPS time" to "Synchronization".

For LE-8600X 2) set "Ext. PPS" to "Synchronization".

Also, uncheck "Invert PPS polarity".

 Do not connect the GPS antenna to 2).

- Usage of an external PPS device

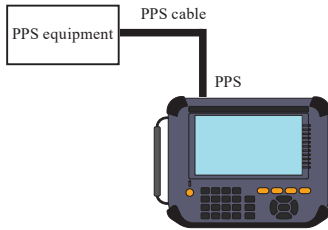

To synchronize the time stamp of LE-8600X with the PPS signal output device, an optional PPS cable is needed.

For LE-8600X set “Ext. PPS” to “Synchronization”.

Check “Invert PPS polarity” according to the PPS signal output device to be used.

 Do not connect a GPS antenna.

## 3.5 Start and Stop Measurement

- Starting measurement

Press [RUN]. The display at the top left of the screen changes from “■” to “●”, and the data is captured in the capture buffer.

Time	Len	P	Source	Dest	Protocol
32:17.445902	215	A	192.168.0.7	239.255.255.250	UDP
32:18.071925	60	A	192.168.0.20	192.168.0.106	TCP
32:18.073329	60	B	192.168.0.106	192.168.0.20	TCP
32:18.123813	60	A	192.168.0.20	192.168.0.106	TCP
32:18.815690	60	A	192.168.0.20	192.168.0.106	TCP
32:18.816303	60	B	192.168.0.106	192.168.0.20	TCP
32:18.837183	60	B	192.168.0.106	192.168.0.20	TCP
32:18.837412	60	A	192.168.0.20	192.168.0.106	TCP
32:19.222895	60	A	00:24:A5:4B:8A:86	FF:FF:FF:FF:FF:FF	[8899]
32:19.420985	60	A	10:6F:3F:B3:56:DC	FF:FF:FF:FF:FF:FF	[8899]
32:20.767703	60	A	192.168.0.20	192.168.0.106	TCP
32:20.769108	60	B	192.168.0.106	192.168.0.20	TCP
32:20.811334	60	A	192.168.0.20	192.168.0.106	TCP
32:21.222682	60	A	00:24:A5:4B:8A:86	FF:FF:FF:FF:FF:FF	[8899]
32:21.343442	60	A	192.168.0.20	192.168.0.106	TCP

- Stop measurement

Press [STOP] to finish the measurement. Or it also stops measurement when the trigger condition has been met.

## 3.6 Display

Press [ENTER] key. Frame display, can be changed to, Detailed display .

- Frame display

It displays the LAN frames with the time stamp information on the screen.

Time stamp

Source address

Destination address

Protocol

mm:ss.µsec	Len	P	Source	Dest	Protocol
32:17.445902	215	A	192.168.0.7	239.255.255.250	UDP
32:18.071925	60	A	192.168.0.20	192.168.0.106	TCP
32:18.073329	60	B	192.168.0.106	192.168.0.20	TCP
32:18.123813	60	A	192.168.0.20	192.168.0.106	TCP
32:18.815690	60	A	192.168.0.20	192.168.0.106	TCP
32:18.816303	60	B	192.168.0.106	192.168.0.20	TCP
32:18.837183	60	B	192.168.0.106	192.168.0.20	TCP
32:18.837412	60	A	192.168.0.20	192.168.0.106	TCP
32:19.222895	60	A	00:24:A5:4B:8A:86	FF:FF:FF:FF:FF:FF	[8899]
32:19.420985	60	A	10:6F:3F:B3:56:DC	FF:FF:FF:FF:FF:FF	[8899]
32:20.767703	60	A	192.168.0.20	192.168.0.106	TCP
32:20.769108	60	B	192.168.0.106	192.168.0.20	TCP
32:20.811334	60	A	192.168.0.20	192.168.0.106	TCP
32:21.222682	60	A	00:24:A5:4B:8A:86	FF:FF:FF:FF:FF:FF	[8899]
32:21.343442	60	A	192.168.0.20	192.168.0.106	TCP

“Time Resolution”

ss.nsec or mm:ss.µsec \* 1

↓

hh : mm : ss . msec

↓

MM / DD hh : mm : ss

↓

YY / MM / DD hh : mm

↓

Δ time(sec) \*2

\*1: Displayed resolution of time stamp is set in the configuration.

\*2: Elapsed time from previous frame.

Press [SHIFT]+ “Relative Time” to start the time stamp from zero when it starts measuring.

You can scroll the screen by [▲] [▼] or swipe.

- Detailed display

Display the details of the frame, which is displayed on the top of the Frame Display.

“Dump” : The translation view can be changed to the HEX dump view.

- Translation view

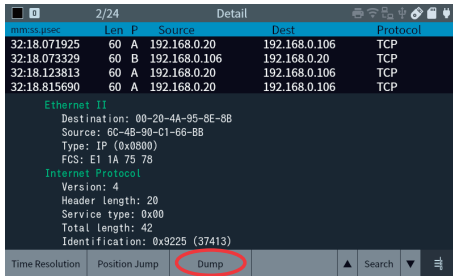

Refer to the specifications of each protocol to understand the contents of the protocol.

If you are using timestamp synchronization, you can check the synchronization status in the GPS/PPS Sync.Status item added to the detail view. Immediately after the start of measurement, as the synchronization is not completed it will be NG, and after synchronization is completed it will be OK.

- HEX dump view

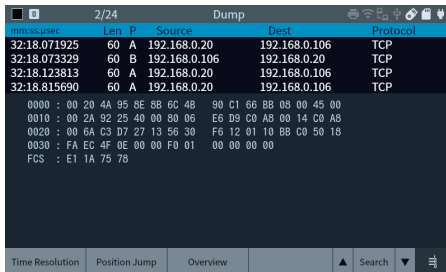

← The target frame for dump view.

It is able to scroll data by swiping the screen.

↳ Dump display of Ethernet frame.

↳ Scroll frames by [ ▲ ] [ ▼ ] keys.

When data that exceeds the capture performance of this unit flows on the line such as when a large amount of short packets are sent continuously or when packets are sent in both directions at a high load simultaneously, it may have a capture loss. In such a case, “OVERRUN” is displayed at the point where the capturing loss occurred. When opening Auto Save log data, the packet right above the “OVERRUN” may be broken off midway, in that case, it can not be displayed correctly.

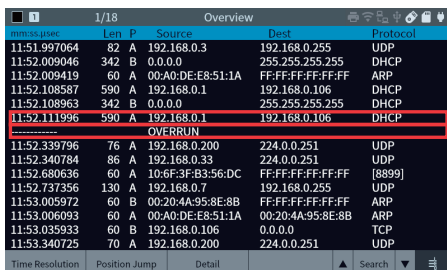

← Broken off Data packet can not be displayed correctly.

← “OVERRUN” display

- Split Display

The data stored in BUF1 and BUF2 can be displayed simultaneously on the measurement data screen.

By comparing the two measurement data, analysis can be performed more efficiently, such as detecting differences in the event of a failure.

- 1) Save the measurement data in BUF1 or BUF2. On the recording control setting screen, set the buffer to be used to either BUF1 or BUF2, and prepare the measurement data by executing the measurement or loading the file.
- 2) Press [SHIFT] + “Change Buffer” to prepare another measurement data in the other buffer by executing the measurement or loading a file.
- 3) You can display both buffers on one screen by pressing [SHIFT] + “Split Display”.

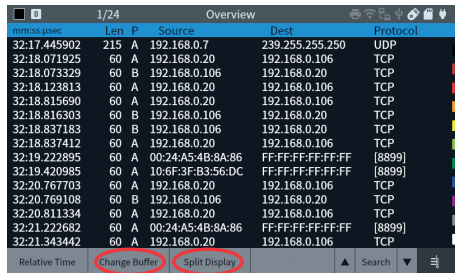

The two data screens scroll individually, but if you want to scroll at the same time, tap “SYNC”.

You can scroll two data at the same time by pressing the [▲] [▼] keys.

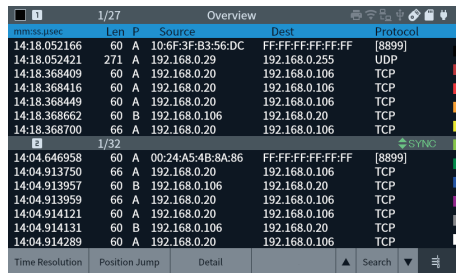
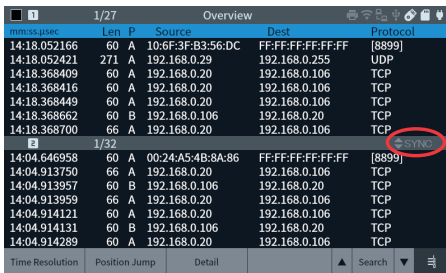

- Position Jump

Display from the specified frame.

Tap “Position Jump” and enter the frame number to jump to.

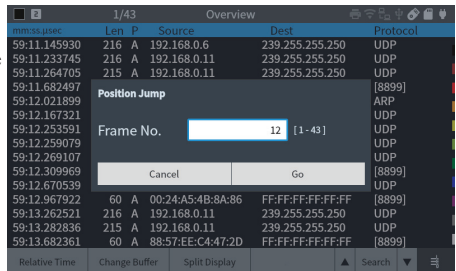

- Mark & Jump

By marking a frame you can jump to the frame with a single key.

Marks can be added up to 9 places.

When you just made a jump to mark, by the single key you can return to the frame where it was before the mark jump.

Mark set : [SHIFT] + [1]-[9]

Jump to Mark : [1]-[9]

Canceling the jump to Mark : [0]

The marked frame shows the same M1 to M9 as the given key.

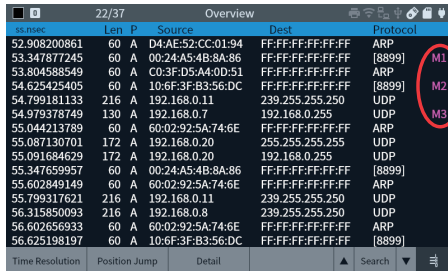

The screenshot shows the Wireshark network traffic overview window. The table below represents the data visible in the table:

Time	Len	P	Source	Dest	Protocol	Mark
52.908200861	60	A	D4:AE:52:CC:01:94	FF:FF:FF:FF:FF:FF	ARP	M1
53.347877245	60	A	00:24:A5:4B:8A:86	FF:FF:FF:FF:FF:FF	[8899]	
53.804588549	60	A	C0:3F:D5:A4:0D:51	FF:FF:FF:FF:FF:FF	ARP	M2
54.625425405	60	A	10:6F:3F:B3:56:DC	FF:FF:FF:FF:FF:FF	[8899]	
54.799181133	216	A	192.168.0.11	239.255.255.250	UDP	M3
54.979378749	130	A	192.168.0.7	192.168.0.255	UDP	
55.044213789	60	A	60:02:92:5A:74:6E	FF:FF:FF:FF:FF:FF	ARP	
55.087130701	172	A	192.168.0.20	255.255.255.255	UDP	
55.091684629	172	A	192.168.0.20	192.168.0.255	UDP	
55.347659957	60	A	00:24:A5:4B:8A:86	FF:FF:FF:FF:FF:FF	[8899]	
55.602849149	60	A	60:02:92:5A:74:6E	FF:FF:FF:FF:FF:FF	ARP	
55.799317621	216	A	192.168.0.11	239.255.255.250	UDP	
56.315850093	216	A	192.168.0.8	239.255.255.250	UDP	
56.602656933	60	A	60:02:92:5A:74:6E	FF:FF:FF:FF:FF:FF	ARP	
56.625198197	60	A	10:6F:3F:B3:56:DC	FF:FF:FF:FF:FF:FF	[8899]	

If you execute a numbering operation to a mark where there is the same number, the mark will be deleted.

If you set a mark of a different number, it will overwrite the existing mark.

## 3.7 Retrieval Function

With the search function, you can find specific data.

The search conditions can be set by tapping “Search”.

Tap “Find Next.” “Find Prev.” From the condition setting screen to execute the search in that direction.

Press “▼” “▲” on the frame display screen to continue the search.

Time	Len	P	Source	Dest	Protocol
32:17.445902	215	A	192.168.0.7	239.255.255.250	UDP
32:18.071925	60	A	192.168.0.20	192.168.0.106	TCP
32:18.073329	60	B	192.168.0.106	192.168.0.20	TCP
32:18.123813	60	A	192.168.0.20	192.168.0.106	TCP
32:18.815690	60	A	192.168.0.20	192.168.0.106	TCP
32:18.816303	60	B	192.168.0.106	192.168.0.20	TCP
32:18.837183	60	B	192.168.0.106	192.168.0.20	TCP
32:18.837412	60	A	192.168.0.20	192.168.0.106	TCP
32:19.222895	60	A	00:24:A5:4B:8A:86	FF:FF:FF:FF:FF:FF	[8899]
32:19.420985	60	A	10:6F:3F:B3:56:DC	FF:FF:FF:FF:FF:FF	[8899]
32:20.767703	60	A	192.168.0.20	192.168.0.106	TCP
32:20.769108	60	B	192.168.0.106	192.168.0.20	TCP
32:20.811334	60	A	192.168.0.20	192.168.0.106	TCP
32:21.222682	60	A	00:24:A5:4B:8A:86	FF:FF:FF:FF:FF:FF	[8899]
32:21.343442	60	A	192.168.0.20	192.168.0.106	TCP

Search Parameters

Param1 Param2

Action Count

Error Condition All

Frame Length 1 9216

Port All

Data Filter

Data Type Layer2

Type Field [0] IPv4

Find Prev Find Next

- Action
  - Specify on the Param 1 tab.
  - Select “Display” to jump to the frame that meets the conditions.
  - Select “Count” to display the number of frames that satisfy the conditions before or after the current cursor position.
- Param 2 Valid
  - Condition 2 Specify on the Param 2 tab.
  - By checking it, you can set condition 2 which is to be searched by condition 1 and OR condition.
- Error Condition
  - Select this when you want to search for the frame where the error occurred.
- Frame Length
  - When you want to specify the frame length condition, check it and enter the range. Minimum 1 to maximum 9216. Specify a length that does not include FCS.
- Port
  - Select to specify a frame of a specific LAN port.
- Data Filter
  - When you want to search by the condition of the frame contents, check it and enable the items after this.
- Data Type
  - Select the type to search from “Layer2” or “IPv4”.

## <Layer2>

Set the conditions of MAC header for target frame.

- Type Field

Select the type field from IPv4, ARP, NetBIOS, IPv6, EtherCAT, Custom (specify the number) and All.

- Number

Input the type number, in the case of the selecting “Custom” at “Type field” .

- Destination Address

By checking it, you can specify the destination (Dst) address.

- Source Address

By checking it, you can specify the source (Src) address.

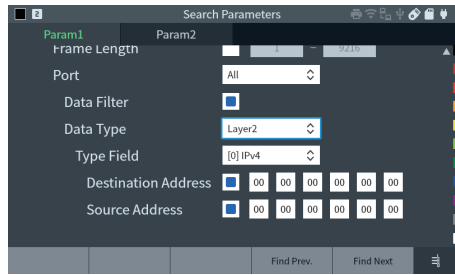

## <IPv4>

Set the conditions of IP header for IPv4 frame.

- Protocol Field

Select the protocol field from ICMP, IGMP, TCP, UDP, Custom (specify the number) and All.

- Number

Input the protocol number, in the case of the selecting “ Custom ” at “ Protocol Field ” .

- Destination Port

Input the destination port number when TCP or UDP is selected in the Protocol field.

- Source Port

Input the source port number when TCP or UDP is selected in the Protocol field.

- Destination Address

By checking it, you can specify the destination (Dst) address.

- Source Address

By checking it, you can specify the source (Src) address.

- Subnet Mask

By checking it you can specify the subnet mask.

The target range is the network address obtained by the bitwise AND calculated by this value and the specified values of destination (Dst) and source (Src) address.

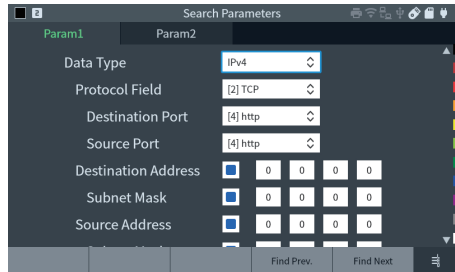

## 3.8 Trigger Function

Triggers can be made by matching the specified conditions of the frame or by an external input signal. A trigger can automatically stop the measurement. It is also possible to count the number of frames that match the conditions.

 1-2 extra data may be recorded before the actual stop.

Tap “Trigger” from the top menu screen and set the trigger conditions on the trigger setting screen.

- EXT TRG Enable

When checked, the L level (TTL level) of the external signal connected to IN1 of the external input/output terminal will be the trigger.

- Frame TRG Enable

Enable/disable the frame detection trigger.

- Action

Select “Stop RUN” to stop the measurement when a trigger occurs or “Count” to count the number of triggers.

- Factor Type

Select the frame type from “Layer2” or “IPv4”.

- Trigger Output

Set the L level (TTL level) signal width to be output to OUT1 of the external input/output terminal when a trigger occurs.

- RUN Stop Buzzer

When checked, a buzzer will sound for 2 seconds when the RUN stops due to trigger conditions.

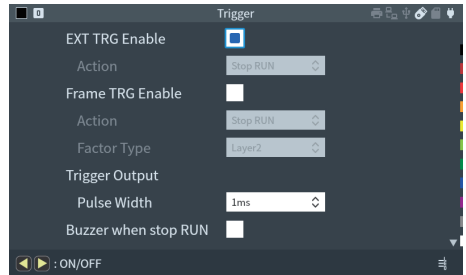

<Layer2>

Configuration of the MAC header of specified frames.

- Type Field

Select the type field from IPv4, ARP, Net Bios, IPv6, Custom(specified number), or ALL(without specifying).

- Number

Enter a type number when you have chosen “ Custom ” at Type field.

- Destination Address

By checking it, you can specify the destination (Dst) address.

- Source address

By checking it, you can specify the source (Src) address.

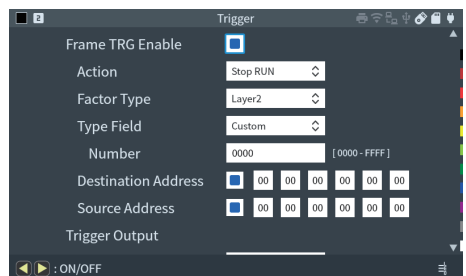

## <IPv4>

Configuration of the IP header of IPv4 frames.

- Protocol Field

Select the protocol field from ICMP, IGMP, TCP, UDP, Custom(specified number), or ALL(without specifying).

- Number

Enter a protocol number when you have chosen “Custom” at Protocol field.

- Destination Port

Specify the destination port number when TCP / UDP is selected in the protocol field.

- Source Port

Specify the source port number when TCP / UDP is selected in the protocol field.

The destination (Dst) and source (Src) ports do not work well if the frame’s IP header has options.

- Destination Address

By checking it, you can specify the destination (Dst) address.

- Source Address

By checking it, you can specify the source (Src) address.

- Subnet Mask

By checking it you can specify the subnet mask.

The target range is the network address obtained by the bitwise AND calculated by this value and the specified values of destination (Dst) and source (Src) address.

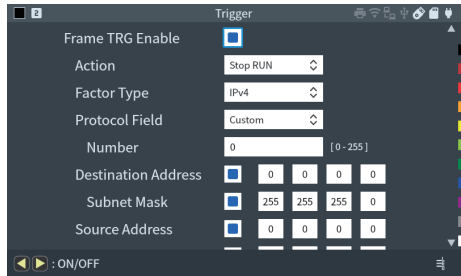

Frame display screen when a trigger occurs

“T” is displayed for the frame where the trigger occurred. If the trigger action is set to “count”, the number of how many triggers occurred will be displayed on the screen.

Time	Len	P	Source	Dest	Protocol
10:06.412167	86	A	34:9F:7B:46:41:09	33:33:00:00:01:51	IPv6
10:06.413309	86	A	34:9F:7B:46:41:09	33:33:00:01:00:03	IPv6
10:06.414337	86	A	34:9F:7B:46:41:09	33:33:00:00:00:0C	IPv6
10:06.432499	130	A	28:39:26:9C:1A:6D	33:33:00:00:00:16	IPv6
10:06.702115	150	A	5C:EA:1D:1E:2F:77	33:33:00:00:00:16	IPv6
10:06.827331	150	A	D8:60:A6:9A:35:15	33:33:00:00:00:16	IPv6
10:08.865083	60	A	BC:5C:4C:A8:8B:C5	FFFFFFFF:FFFF	ARP
10:09.865085	60	A	BC:5C:4C:A8:8B:C5	FFFFFFFF:FFFF	ARP
10:36.375024	60	A	192.168.2.1	224.0.0.1	IGMP
10:36.390122	60	A	192.168.2.100	224.0.0.251	IGMP
10:36.429730	60	A	192.168.2.100	224.0.0.252	IGMP
10:36.430637	60	A	192.168.2.100	239.255.255.250	IGMP
10:36.436274	70	A	192.168.2.103	224.0.0.22	IGMP
10:36.695020	70	A	192.168.2.104	224.0.0.22	IGMP
10:36.814429	70	A	192.168.2.102	224.0.0.22	IGMP

# Chapter 4 SFP Module Information Display Function

Detailed information on the SFP module inserted in the unit can be displayed.

- 📄 Some SFP modules (mainly copper modules) do not have diagnostic information.
- 📄 This also applies to our optional products “LE-1G-BT-45”, “LE-10G-BT-45” and “LE-2G5-BT-45”.

## 4.1 Connection method

Insert the SFP module to be measured into PORT A and PORT B of the unit.



## 4.2 Information display

Select “SFP Info” from “Mode” on the top menu screen and press [RUN] to display the basic information of the SFP module.

See SFF-8472 for details.

	Port A	Port B
Identifier	SFP or SFP+	SFP or SFP+
Ext. Identifier	0x04	0x04
Connector	LC (Lucent Connector)	LC (Lucent Connector)
10G Compliance	10GBASE-LR	10GBASE-SR
Ethernet Compliance		
Encoding	64B/66B	64B/66B
Signaling Rate, Nominal	10300MBd	10300MBd
Rate Identifier	Rate Identifier 0x00	Rate Identifier 0x00
Length (m) km	Unspecified	Unspecified

- “Transceiver ”

Displays detailed information about transceiver standards.

	PortA	PortB
<b>10G Ethernet Compliance</b>		
10G BASE-SR	No	No
10G BASE-LR	No	No
10G BASE-LRM	No	No
10G BASE-ER	No	No
<b>Infiniband Compliance</b>		
1X Copper Passive	No	No
1X Copper Active	No	No
1X LX	No	No
1X SX	No	No

- “Diagnostic”

Displays diagnostic information for SFP modules.

	Temp	Volt	Bias	Tx Pwr	Rx Pwr	Laser Temp	TEC Curr
<b>Port A</b>							
Now	33.64	3.26	24.38	0.27360	0.00000	0.00	0.00
Alarm H	80.00	3.60	75.00	0.79430	0.79430	0.00	0.00
Warn H	70.00	3.50	70.00	0.50110	0.50110	0.00	0.00
Warn L	0.00	3.10	2.00	0.12580	0.00790	0.00	0.00
Alarm L	-10.00	3.00	1.00	0.07940	0.00500	0.00	0.00
<b>Port B</b>							
Now	27.81	3.20	3.71	0.30790	0.00000	0.00	0.00
Alarm H	80.00	3.60	12.00	0.79430	0.79430	0.00	0.00
Warn H	70.00	3.50	10.00	0.50110	0.50110	0.00	0.00
Warn L	0.00	3.10	1.60	0.11220	0.01990	0.00	0.00
Alarm L	-10.00	3.00	1.00	0.07070	0.01250	0.00	0.00

# Chapter 5 Statistic Function

The statistic function is a useful feature to analyze the network traffic and the frequency of the particular frames. To use this function, select “Trend” from mode on the top menu screen.

## 5.1 Connection

Connect the target network to the port A/B of analyzer.



## 5.2 Frame Counters

Start the measurement. Following frames are counted separately by transmission and reception. Select two kinds of frames for statistical analysis.

Total	: Total number of receiving frames
Good	: Number of normal frames
Broadcast	: Number of broadcasts
Multicast	: Number of multicasts
Pause	: Number of pause frames
0-63(Length1)	: Number of 0 to 63 byte packets
64(Length2)	: Number of 64 byte packets
65-127(Length3)	: Number of 65 to 127 byte packets
128-255(Length4)	: Number of 128 to 255 byte packets
256-511(Length5)	: Number of 256 to 511 byte packets
512-1023(Length6)	: Number of 512 to 1023 byte packets
1024-1518(Length7)	: Number of 1024 to 1518 byte packets
1519-Over(Length8)	: Number of 1519 byte packets and above
CRC error	: Number of CRC errors
Fragment error	: Number of fragment errors <sup>*1</sup>
Data Rate(1sec.)	: Current data transfer rate (updated every second) <sup>*2</sup>
Data Rate(Avg)	: Average data transfer rate at the time interval specified on the setting screen

\*1 Frame where an FCS error occurs and its packet length is less than 64 bytes.

\*2 This value cannot be set as a statistical analysis target for graph display.

## 5.3 Statistical analysis settings

Tap “Trend Opt.” from the Statistical analysis function mode.

- Target  
Select the target from transmission line and reception line.  
Tx : Transmission signal  
Rx : Reception signal

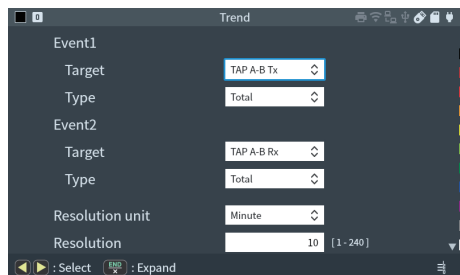

- Type  
Select the target frame counter.
- Resolution unit  
Select the unit of the counting cycle from seconds or minutes.
- Resolution  
When the counting cycle unit is minutes, enter the counting cycle (resolution of the horizontal axis of the statistical graph) in the range of 1 to 240 (minutes), and when it is seconds, enter in the range of 2 to 240 (seconds).

## 5.4 Start and Stop Measurement

- Start measurement  
Press [RUN] to start measuring.
- Stop measurement  
Press [STOP] to stop measuring.  
A measurement is automatically terminated when 100,000 statistics are completed or one of the statistics counters reaches the maximum count of 4,294,967,295.

## 5.5 Display

Each time you tap “Graph” or “Counter”, the display changes.

- Graph display  
Counted values are shown in histogram by unit time of statistics.

“Auto Range ON/OFF” :

Enables/disables the auto range function.

“Range UP” [▲]

“Range Down” [▼] :

When auto range is off, the resolution of the vertical axis of the graph is changed.

After the measurement is completed, you can scroll the screen with [▲][▼] or by swipe.

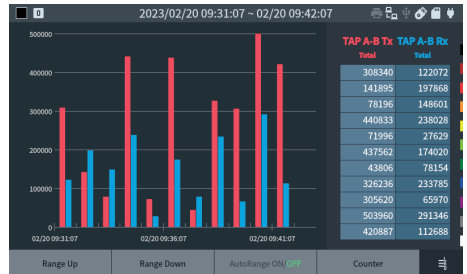

- Counter display  
It shows the total numbers of each counter frame.  
“Data Rate” item displays the data rate.  
Maximum number of counts : 4,294,967,295

	TAP A-B Tx	TAP A-B Rx
4294967byte	0	0
256-511byte	0	0
512-1023byte	0	0
1024-1518byte	4795566	0
1519byte-Over	0	0
CRC Error	0	0
Fragment Error	0	0
Data Rate (1 sec.)	9.84456 Gbps	0.00000 Kbps
Data Rate (Avg.)	5.73991 Gbps	0.00000 Kbps

# Chapter 6 Packet Generator Function

You can transmit any packet by Packet Generator function. To use this function, select [PG] from mode on the top menu screen.

## 6.1 Connection

Connect a target device to test to Port A or B.

## 6.2 Transmission settings

Tap “PG Opt.” from the PG function mode screen to display the PG setting screen.

Set the content and conditions for transmission of packets for Port A and Port B respectively.

- Output Enable  
By checking it, packet generation will be performed on that port.
- Edit send table  
Edit the contents of the packet to be sent.
- Continuous  
When checked, transmission is made continuously.  
When not checked, specify the number of times to send.
- Repeat count  
When “continuous” mode is not set, it transmits packets for the specified number of times.

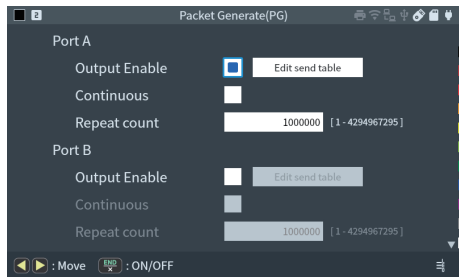

## 6.3 Transmission packet summary

On the PG setting screen, tap “Edit send table” to display a summary of transmission packets.

There are 16 types of transmission tables from No.0 to No.F, and you can enable/disable them individually with the “Select” check box.

No.	Select	Length	Pattern	FrameGap
0	<input checked="" type="checkbox"/>	54	12 34 56 78 9A BC FE DC	128
1	<input type="checkbox"/>	0		128
2	<input type="checkbox"/>	0		128
3	<input type="checkbox"/>	0		128
4	<input type="checkbox"/>	0		128
5	<input type="checkbox"/>	0		128
6	<input type="checkbox"/>	0		128
7	<input type="checkbox"/>	0		128
8	<input type="checkbox"/>	0		128

## 6.4 Editing the transmission packets

You can edit the contents of the table by tapping the table or selecting it with the cursor and pressing Enter or [0]-[F].

- Transmission data input

Set the transmission data.

On the screen, it displays the cursor position in “Pos” and the number of bytes that can be registered in “Remain”.

- 📄 Enter the data in hexadecimal.
- 📄 Packet data can be entered up to a total of 32000 bytes in 16 tables.
- 📄 Enter the data column for the packet that does not contain the FCS.

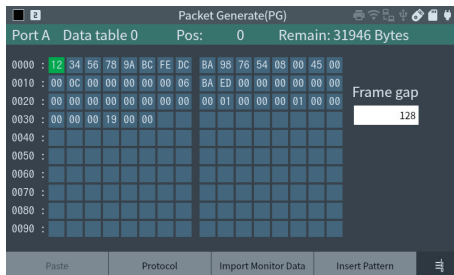

If you long-tap somewhere in the transmission data or press “ENTER”, the range selection mode starts with the data on the location selected. The selection range can be changed by dragging the selection end or [◀][▶]. The length of the selected range is displayed in “Len” on the screen.

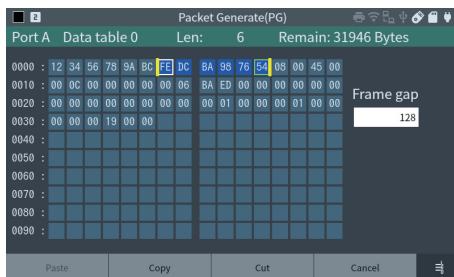

Tap “Paste” “Copy” to save the selection to the clipboard.

Tap [ESC] or “Cancel” to cancel the range selection mode.

Tap “Paste” to insert the contents of the clipboard at the cursor position.

- Frame gap input

SIIt should be a multiple of 32.

- Protocol Setup

Protocol Setup display shows by pushing “Protocol” at the data table summary display.

Configuration of the selected protocol type (Ethernet, IPv4, ARP, ICMP, TCP, UDP) shows and you can set up a header of the protocol.

According to the protocol and data registration details, it displays the source MAC address, destination MAC address, frame type, etc. By tapping “Apply”, it item overwrites the corresponding data items with the one entered on the protocol edit screen and then returns to the transmission data input screen. Tap “Cancel” or [ESC] to return to the transmission data input screen without changing the data.

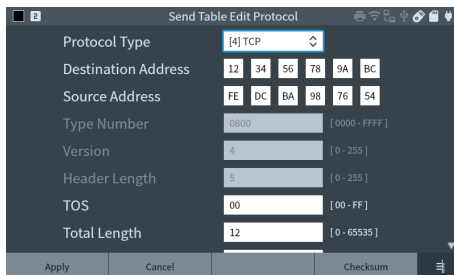

The table below shows the items of the protocols.

To overwrite values of the items, edit the values of the items which you want to change and tap “Apply” .

(For the further details of items of the protocols, refer to standards of the protocols.)

Item	Default Value	Input Value	Remark
<Ethernet>			
Destination MAC address	00-00-00-00-00-00	Hex	
Source MAC address	00-00-00-00-00-00	Hex	
Type	0000	Hex	
<IPv4>			
Destination MAC address	00-00-00-00-00-00	Hex	
Source MAC address	00-00-00-00-00-00	Hex	
Type	0800	Hex	Fixed (cannot overwrite)
Version	4	Decimal	Fixed (cannot overwrite)
Header length	5	Decimal	Fixed (cannot overwrite)
TOS	00	Hex	
Total length	0	Decimal	
ID	0000	Hex	
Flags	0	Decimal	
Fragment offset	0	Decimal	
TTL	0	Decimal	
Protocol	0	Decimal	
Checksum	0000	Hex	*1
Source IP address	0.0.0.0	Decimal	
Destination IP address	0.0.0.0	Decimal	
<ARP>			
Destination MAC address	00-00-00-00-00-00	Hex	
Source MAC address	00-00-00-00-00-00	Hex	
Type	0806	Hex	Fixed (cannot overwrite)
Hardware type	0001	Hex	Fixed (cannot overwrite)
Protocol type	0800	Hex	Fixed (cannot overwrite)
Hardware length	6	Hex	Fixed (cannot overwrite)
Protocol length	4	Decimal	Fixed (cannot overwrite)
Operation code	0000	Hex	
Source MAC Address	00-00-00-00-00-00	Hex	
Source IP address	0.0.0.0	Decimal	
Destination MAC address	00-00-00-00-00-00	Hex	
Destination IP address	0.0.0.0	Decimal	
<ICMP>			
Destination MAC address	00-00-00-00-00-00	Hex	
Source MAC address	00-00-00-00-00-00	Hex	
Type	0800	Hex	Fixed (cannot overwrite)
Version	4	Decimal	Fixed (cannot overwrite)
Header length	5	Decimal	Fixed (cannot overwrite)
TOS	00	Hex	
Total length	0	Decimal	
ID	0000	Hex	
Flags	0	Decimal	
Fragment offset	0	Decimal	
TTL	0	Decimal	
Protocol	1	Hex	Fixed (cannot overwrite)
Checksum	0000	Hex	*1
Source IP address	0.0.0.0	Decimal	

Destination IP address	0.0.0.0	Decimal	
Type	0	Decimal	
Code	0	Decimal	
Checksum	0000	Hex	*1
<TCP>			
Destination MAC address	00-00-00-00-00-00	Hex	
Source MAC address	00-00-00-00-00-00	Hex	
Type	0800	Hex	Fixed (cannot overwrite)
Version	4	Decimal	Fixed (cannot overwrite)
Header length	5	Decimal	Fixed (cannot overwrite)
TOS	00	Hex	
Total length	0	Decimal	
ID	0000	Hex	
Flags	0	Decimal	
Fragment offset	0	Decimal	
TTL	0	Decimal	
Protocol	6	Decimal	Fixed (cannot overwrite)
Checksum	0000	Hex	*1
Source IP address	0.0.0.0	Decimal	
Destination IP address	0.0.0.0	Decimal	
Source port	0	Decimal	
Destination port	0	Decimal	
Sequence number	0	Decimal	
ACK number	0	Decimal	
Data offset	0	Decimal	
Reserved	0	Decimal	
NS	0	Decimal	
CWR	0	Decimal	
ECE	0	Decimal	
URG	0	Decimal	
ACK	0	Decimal	
PSH	0	Decimal	
RST	0	Decimal	
SYN	0	Decimal	
FIN	0	Decimal	
Window	0	Decimal	
Checksum	0000	Hex	*1
Urgent pointer	0	Decimal	
<UDP>			
Destination MAC address	00-00-00-00-00-00	Hex	
Source MAC address	00-00-00-00-00-00	Hex	
Type	0800	Hex	Fixed (cannot overwrite)
Version	4	Decimal	Fixed (cannot overwrite)
Header length	5	Decimal	Fixed (cannot overwrite)
TOS	00	Hex	
Total length	0	Decimal	
ID	0000	Hex	
Flags	0	Decimal	
Fragment offset	0	Decimal	
TTL	0	Decimal	
Protocol	17	Decimal	Fixed (cannot overwrite)
Checksum	0000	Hex	*1
Source IP address	0.0.0.0	Decimal	

Destination IP address	0.0.0.0	Decimal	
Source port	0	Decimal	
Destination port	0	Decimal	
Length	0	Decimal	
Checksum	0000	Hex	*1

**\*1 Checksum calculation**

Checksums of IP frame, ICMP, TCP, UDP can be automatically calculated by tapping “Checksum”.

 If field value (which means length) and number of data of payload and padding do not correspond, calculation will be incorrect.

**■ Importing monitor data**

You can copy the frame contents in the capture memory taken by the online monitor function into the table.

Put data into the capture memory in advance by starting measurement or using the file load function to use this function.

Tap “Import Monitor Data” to display the frame display screen for selecting the frame to import.

The part with the background color at the top of the screen is the frame to be imported. Select data by scrolling the screen and tap “Import” to reflect the packet contents into the transmitted packet table of the PG function.

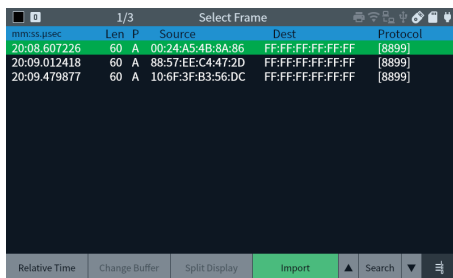

**■ Pattern insertion**

You can register sequential number data of arbitrary length in the transmission data table.

Move the cursor to the position where you want to insert the data, and tap “Insert Pattern”. Select the pattern type and parameters and tap “OK” to insert the data for the specified length.

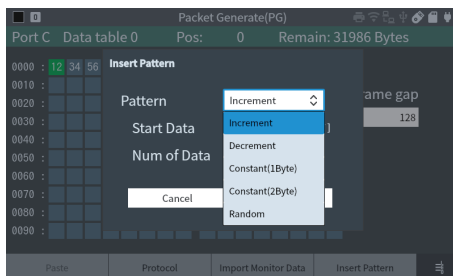

- Increment Inserts ascending sequential numbers (Loops with 0x00 after 0xFF).
- Decrement Inserts descending sequential numbers (Loops with 0xFF after 0x00).
- Constant (1 Byte ) Fills the area with a fixed value.
- Constant (2 Byte ) Inserts two fixed values alternately.
- Random Inserts a random value of between 0x00 and 0xFF.

## 6.5 Start and Stop Testing

When you press [RUN], the “A Port Start” and “B Port Start” parts at the bottom of the screen will be enabled if the link of the transmission port (set one) is established. By tapping here or pressing [A] or [B], the tables set to  (Output Enable) in the send table will be transmitted in sequence. When the number of transmissions is reached, or when you press [STOP], the transmission ends.

## 6.6 Test Result

The result of packet transmission is displayed on the screen.

<Tx Packet>

Total : Number of transmitted frames

<Rx Packet>

Total : Number of received frames

Good : Number of normal frames

Broadcast : Number of broadcasts

Multicast : Number of multicasts

Pause : Number of pause frames

0-63 : Number of 0 to 63 byte packets

64 : Number of 64 byte packets

65-127 : Number of 65 to 127 byte packets

128-255 : Number of 128 to 255 byte packets

256-511 : Number of 256 to 511 byte packets

512-1023 : Number of 512 to 1023 byte packets

1024-1518 : Number of 1024 to 1518 byte packets

1519-Over : Number of 1519 byte packets and above

CRC error : Number of CRC errors

Fragment error : Number of fragment errors

The screenshot shows a table with the following data:

	A Tx	A Rx	B Tx	B Rx
Total	11148	24	0	0
Good	0	0	0	0
Broadcast	0	0	0	0
Multicast	0	0	0	0
Pause	0	0	0	0
0-63byte	0	0	0	0
64byte	0	0	0	0
65-127byte	0	0	0	0

At the bottom of the screen, there are buttons for "A Port Start" and "B Port Start".

# Chapter 7 Ping Function

You can check the link by making this device join a network and send a Ping command. To use the Ping function, select “Ping” from Mode on the top menu screen.

In Ping mode, PORT A and PORT B of this unit switch from the tap circuit to the normal LAN port and join the network to be tested.

## 7.1 Connection

Connect the LAN port of the target device to PORT A of this unit.

## 7.2 Ping Setup

From the Ping function screen, tap “Ping Opt.” To configure it.

- Destination Address  
Enter the IP address of destination.
- Timeout  
Select the time out limit of Ping response.
- Interval  
Select the interval of repeating the Ping request.
- Data Size  
Enter the data size of ping request packet (ICMP).  
 For the normal testing, it is not necessary to change the default value (64).
- DHCP  
Check if you want to connect to the DHCP server environment and obtain an IP address automatically.
- IP Address  
Enter the IP address of this device.
- Subnet Mask  
Enter the subnet mask.
- Default Gateway  
To communicate over the router, enter the IP address of the router.  
(Enter “0.0.0.0” if unnecessary).
- Tagging  
Select “Enable” to use the VLAN tags.

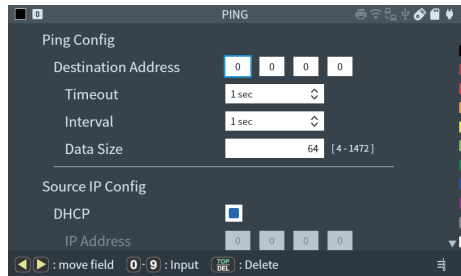

- VLAN ID  
Enter the ID number of the VLAN tag.
- MAC Address  
The MAC address of this device is displayed.

## 7.3 Start and Stop Testing

---

Press [RUN] to start the Ping test.

It sends the ping approximately 30,000 times and the test will end automatically.

If you want to end the test in the middle, press [STOP].

## 7.4 Display

---

During the Ping testing, the situation of test will be described as following.

Send : Number of times transmitted  
 Fail : Number of times failed  
 Current : Latest response time (ms)  
 Minimum : Minimum response time(ms)  
 Maximum : Maximum response time(ms)  
 Average : Average response time (ms)

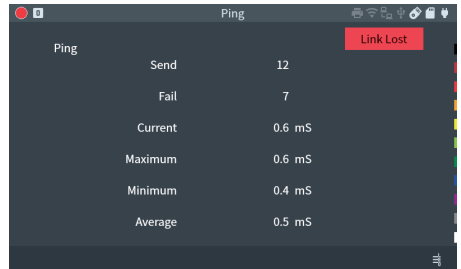

When the Ping commands cannot be transmitted successfully, following message will appear in the upper right of the display.

DHCP Failed: Fail to acquire the IP address from the DHCP server.  
 ARP Failed : Fail to find the Host.  
 Not Link : Fail to link to the network.  
 Link Lost : Fail to link during the transmission.  
 Conflict : When duplicate addresses may exist.

# Chapter 8 Port Blink Function

You can see which port of the hub is connected to the LAN cable by blinking the link LED on the hub connected to PORT A.

This function does not work with some copper modules.

To use the port blink function, select “Blink” from the mode on the top menu screen.

## 8.1 Connection

Plug the LAN cable connected to the HUB into the Port A.

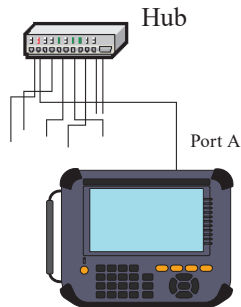

## 8.2 Searching Hub port

Press [RUN] to repeat linking/unlinking from the PORT A to the port of the hub to which PORT A is connected. You can find which port of the HUB is connected to the Port A of analyzer by the link LED of the HUB blinking at the same interval.

To stop blinking, press [STOP].

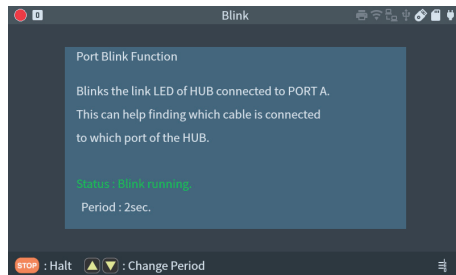

- ☰ The blinking interval could be different by the response time of the HUB. If the response time from the hub is long and it does not blink well, change the blinking interval with the [▲] key.
- ☰ If unplug the cable during the test, blinking may be stopped. In this case, press [STOP] and [RUN] again.

# Chapter 9 Slice Capture Function

The slice capture function captures only the first 60 bytes of an Ethernet frame, reducing capture loss during high traffic periods and conserving capture buffer and external storage usage.

In addition, even when used on a line carrying confidential data, as most of the payload is not recorded, it prevents the leakage of confidential data.

Select “Slicing” from the Mode in the top menu.

- This function is only valid when the interface setting is 10GbE.
- The FCS judgment result is recorded, but the FCS data itself is not recorded.
- “OVERRUN” is displayed where capture loss has occurred.

## 9.1 60 bytes of frame data

Only the first 60 bytes of frame data can be captured.

For most common protocols, the following parts will be captured.

### IPv6

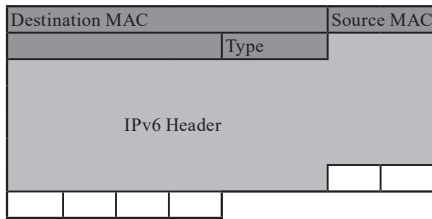

### IPv4 TCP

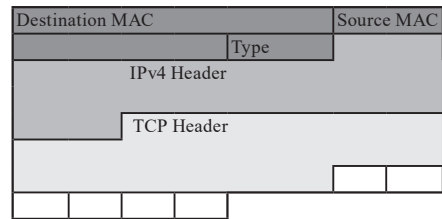

### IPv4 UDP

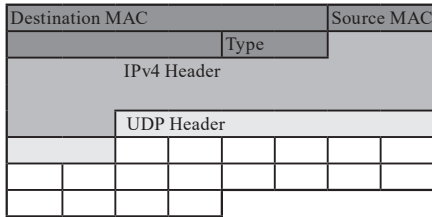

### IPv4 ICMP

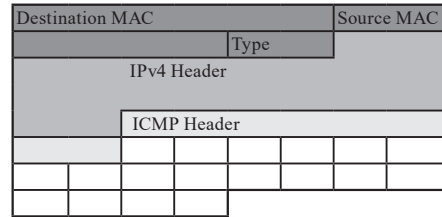



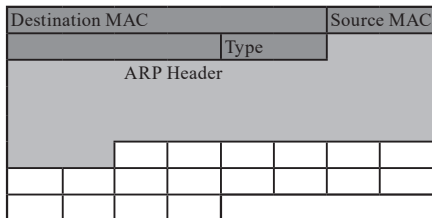

### ARP



## 9.2 Slice Capture Settings

The connection method, filter function, trigger function, and timestamp settings are all the same as the online function.

You can also use the autosave function.

-  3.1 Connection
-  3.3 Filter Setup
-  3.8 Trigger Function
-  2.2.2 Record Control

To set the timestamp, tap “Slicing Opt.” on the slice capture function mode screen and make the settings.

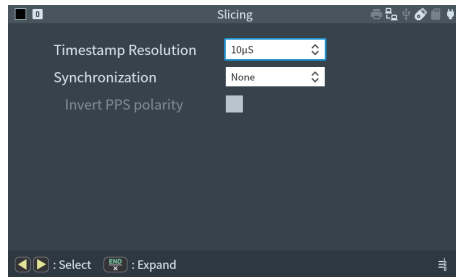

## 9.3 Start and Stop Measurement

Press [RUN] to start measuring.

Press [STOP] to finish the measurement. Or it also stops measurement when the trigger condition has been met.

## 9.4 Test Result

The operation is the same as the online monitor function.

The packet length is not displayed.

Detailed translation is limited to 60 bytes.

Comparison with online monitor function

### ◆ Online Monitor Function

Days h:mm:ss	Len	P	Source	Dest	Protocol
0000 00:00:01	74	A	192.168.0.29	192.168.0.1	ICMP
0000 00:00:01	74	B	192.168.0.1	192.168.0.29	ICMP
0000 00:00:02	74	A	192.168.0.29	192.168.0.1	ICMP
0000 00:00:02	74	B	192.168.0.1	192.168.0.29	ICMP

Source: 192.168.0.29  
Destination: 192.168.0.1  
Internet Control Message Protocol  
Type: Echo (8)  
Code: 0  
Checksum: 0x4D22 - correct  
Identifier: 0x0001 (1)  
Sequence number: 57  
Data:  
61 62 63 64 65 66 67 68 69 6A 6B 6C 6D 6E 6F 70  
71 72 73 74 75 76 77 61 62 63 64 65 66 67 68 69

### ◆ Slice Capture Function

Days h:mm:ss	P	Source	Dest	Protocol
0000 00:00:00	A	192.168.0.29	192.168.0.1	ICMP
0000 00:00:00	B	192.168.0.1	192.168.0.29	ICMP
0000 00:00:01	A	192.168.0.29	192.168.0.1	ICMP
0000 00:00:01	B	192.168.0.1	192.168.0.29	ICMP

Source: 192.168.0.29  
Destination: 192.168.0.1  
Internet Control Message Protocol  
Type: Echo (8)  
Code: 0  
Checksum: 0x4CC2 - incorrect  
Identifier: 0x0001 (1)  
Sequence number: 153  
Data:  
61 62 63 64 65 66 67 68 69 6A 6B 6C 6D 6E 6F 70  
71 72

# Chapter 10 Save and Load of the Data

## 10.1 Storage device

In addition to the built-in SSD, SD/SDHC cards and USB memory can be used as storage devices to save measurement data and setting data.

- Optional SDHC cards (SD-8GX, SD-16GX, SD-32GX, sold by LINEEYE) are available. You can use a USB flash drive, but we do not guarantee the operation of all USB flash drives.
- Storage devices formatted with exFAT or NTFS cannot be used. You need to reformat it with FAT32 before use, but it may not be possible on Windows depending on the version and capacity. Use the tools provided by each storage device manufacturer.

The measurement data automatically saved in the storage device using the auto save function etc. is saved in the storage device specified in “Save Device” of the auto save tab of “Record Control” in [MENU].

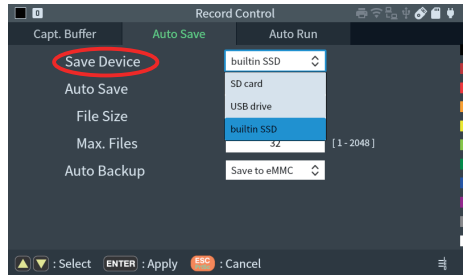

If you select either “USB drive” or “SD card” for “Screen shot save to” in the Display/Power tab of “System Config” in [MENU], the screenshot will be saved in the external storage device. When both storage devices are connected, it will be saved to the storage device specified in this setting.

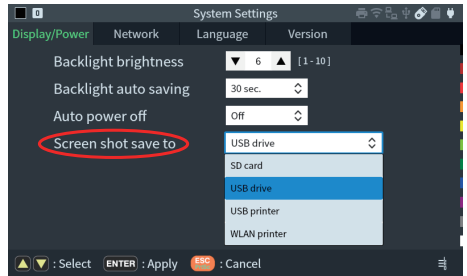

## 10.2 File Management Function

You can save, read, and delete the measured data and setting data in the storage device as a file that can be read/written by a PC.

Tap File Manager on the top menu screen to move to the connected storage directory screen or printer management screen.

Tap “File Manager” or “Device Change” at the bottom of each screen to switch to each screen.

File management operations are performed on the directory screen.

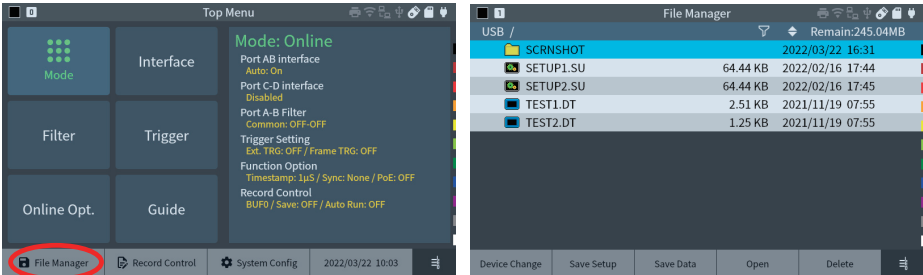

You can scroll and display the files on the directory screen by swiping the screen or by pressing [▼] or [▲]. If you have inserted an SD/SDHC card, USB memory, etc., tap “Device Change” at the bottom of the screen to switch to the directory screen of the storage device you want to operate.

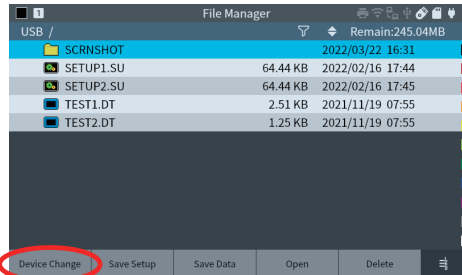
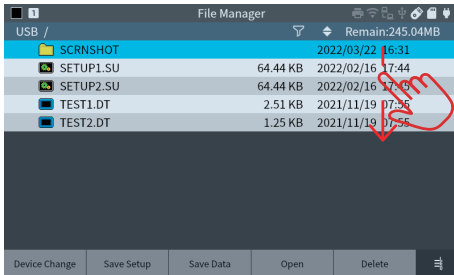



### Save data

When you tap “Save data” on the directory screen, the full key image and text input window will be displayed on the screen.

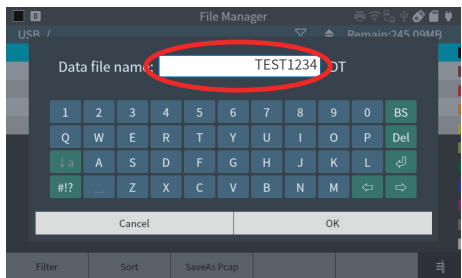
Touch the keyboard or the full key on the screen to enter the file name and tap “OK” or press [ENTER] to save all measurement data in the capture memory and return to the directory screen. The measurement data file extension DT is automatically added.



-  The file name can be specified with up to 8 characters. You cannot enter lowercase letters.
-  Tap “#!?” to enter a symbol that can be used as a file name.

## ◆ Export Data

If you tap [SHIFT]+“Export” on the directory screen, the file export dialog will be displayed. The item to be selected differ depending on the measurement data.

### ■ Export Type

Select the file output format.

pcapng : Outputs ONLINE monitor measurement data in a format that can be opened in Wireshark.

csv : Output TREND measurement data in csv format.

txt : Output ONLINE, TREND measurement data in txt format.

• When the measurement data is “ONLINE monitor” and the output format is txt

### ■ Data Type

From the current position, it transforms the frame display screen by selecting “List” and transforms the detail display screen by selecting “Detail”.

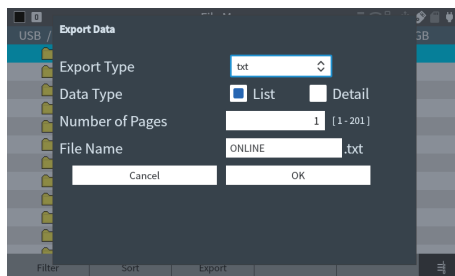

### ■ Number of Pages

Select how many pages to convert from the current position when the data type is List. (15 lines per one page.)

### ■ Number of Lines

Select how many rows of frames to convert from the current position when the data type is Detail.

• When the measurement data is TREND

### ■ Data Type

Select whether the output format is counter or graph.

### ■ Top Position

Displays the top position of the current graph screen.

### ■ Resolution

Displays the resolution of the measurement data.

### ■ Number of Data

Select how many to output from the current top position.

### ■ File Name



Enter a file name. When selected, a file name input dialog is displayed.

Tap “OK” or press [ENTER] to save the file to your storage device.

## Save setup

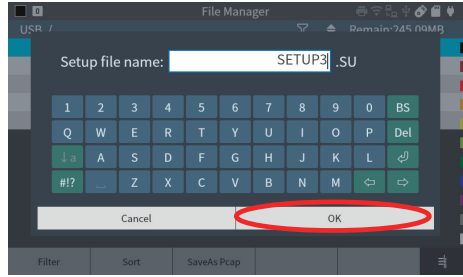
When you touch “Save setup” on the directory screen, the full key image and the text input window will be displayed on the screen. Touch the full key on the screen to enter the file name, and then touch “OK” or press [ENTER] to save all setting data of the top menu and return to the directory screen. The file extension SU of the setting data is automatically added.



-  You can enter the symbols that can be used as the file name by tapping “#!?”.
-  The “System settings” display and Power and network settings are not saved in the setting data file.
-  The “System Settings” display, power setting, and network setting are not saved in the settings data file.

	Never remove the storage device while it is accessing files.
---	--

## File sorting and display filters

### ◆ Sort

Touch “◆” on the directory screen and specify the file name, extension, size, or modification date to display them in ascending or descending order.

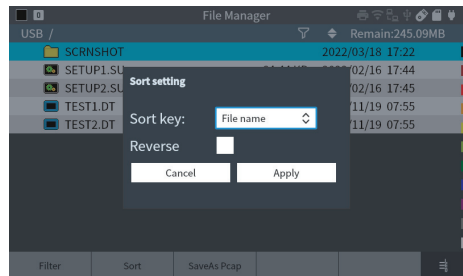
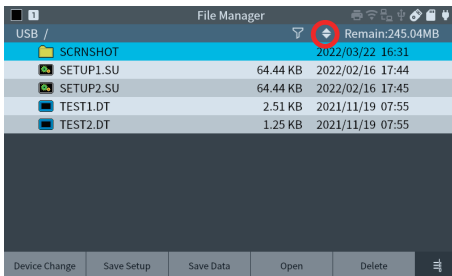

-  The sort display is maintained until you specify it again with “◆” or reboot the device.

## ◆ Filter

Tap “” on the directory screen to display only the specified file type.

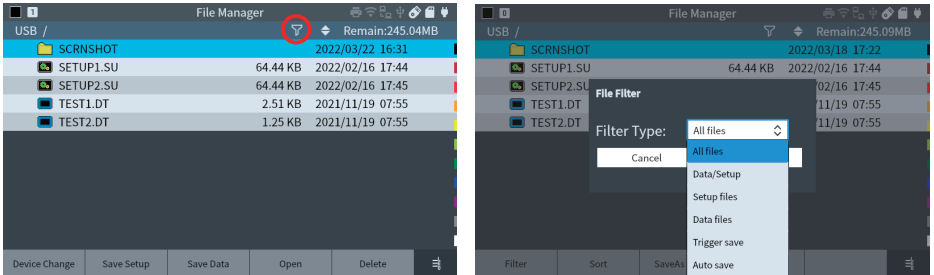

The following file types can be specified for the filter display.

All files

Analyzer measurement data file and setting data file

Analyzer setting data file

Analyzer measurement data file

File automatically saved by the trigger function (TGSAVEnn.DT)

File automatically saved by the auto save function (#nnnnnnn.DT)

When you “Apply” the filter, only the files with the specified conditions will be displayed.

The filter icon turns red while the filter is being applied.

 The filter display will be canceled when you move to another screen.

## Load file

On the directory screen, double-tap the file, or tap the file you want to load or select the file with [▼] or [▲] and then tap “Load File” to load the data of the file. When the setting data file is read, the measurement conditions are uploaded and the menu screen is displayed. When the measurement data file is read, the original measurement data is cleared and the data display screen of the measurement data read from the file is displayed.

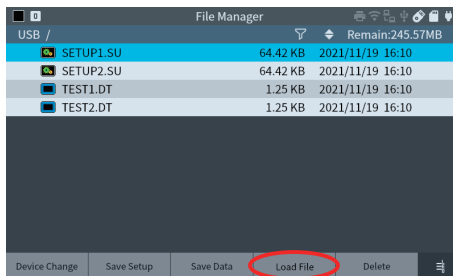



 Files with extensions other than DT, SU, and PNG cannot be loaded.

◆ Loading the file in subdirectory

On the directory screen, double-tap the subdirectory that contains the file you want to read (hereinafter, the folder), or tap it or select it with [▼] or [▲] and then tap “Open” to display the files in that folder. Select the file and execute the load operation.

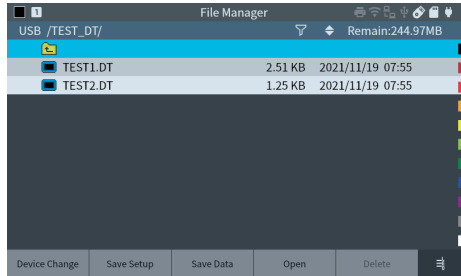
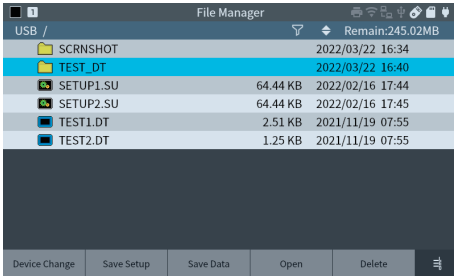
Select “” and touch “Open” to move to the upper directory.



 You cannot create folders or move files to folders on the analyzer. This kind of operation needs to be performed on a PC.

## Delete a file

◆ Delete a file

Tap the file to be deleted on the directory screen or select it with [▼] or [▲], tap “Delete”, and tap “Yes” (or [ENTER]) in the deletion confirmation window to delete the file.

To stop the deletion tap “No”.

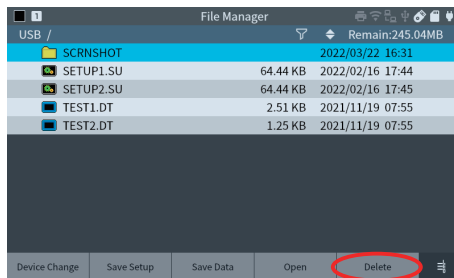

◆ Batch deletion of multiple files

To delete multiple files at once, long-tap (touch for about 1 second) any file on the directory screen to display the file selection display.

Tap the file you want to delete (or select it with [▼] or [▲] and press [ENTER]), and a checkmark will be added to the file. To deselect it tap the selected file again. Tap “Delete” and then tap “Yes” (or [ENTER]) in the deletion confirmation window to delete the selected file.

To cancel the deletion, tap “No”.

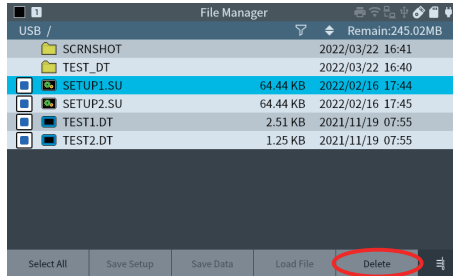

◆ Delete all the files

In the file selection display, tap “Select all” to select all the files displayed in the directory screen. Tap “Delete” and then “Yes” in the confirmation window to delete all the files. When you want to delete all the specified files, for example, only the files automatically saved by the auto save function (#nnnnnn.DT), you can do so by using the filter display of the files.

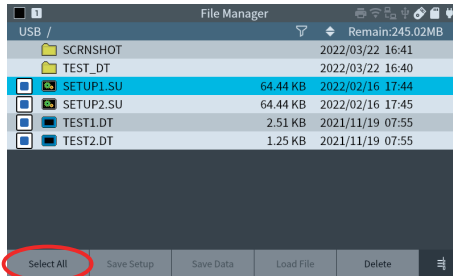

📄 Long tap again or press [ESC] to return to the original display and cancel the selection.

## Error message

If an error message is displayed when accessing the storage device, take appropriate action.

When the data could not be read, the following cases can be considered - the storage device is not recognizable, the capture buffer is write-protected, the data is corrupted, or the data was saved with an optional board other than the one currently in use.

When the data could not be saved, the following cases can be considered - the storage device is not recognized, there is no free space in the saving destination, or the saving destination is write-protected.

# Chapter 11 Utility

## 11.1 Key Emulation Software

You can remotely control the analyzer from your PC via USB, LAN or Wi-Fi (supported model only) displaying the analyzer screen.

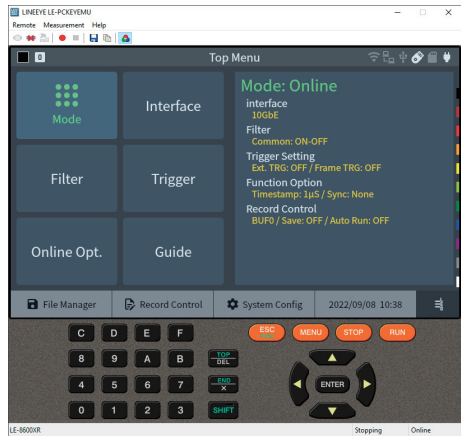

- Preparation
  1. Execute setup.exe in the lepckeyemu folder in the attached CD to install the software.
  2. From the Start menu, select LINEEYE → LE-PCKEYEMU to start it.
  3. Open the remote settings dialog on the toolbar and specify the LE8500X series to connect to.



When you operate the analyzer connected via USB, enter the serial number of it (written on the back of the main unit).

When connected via LAN or Wi-Fi (supported model only), specify the IP address and port number set (or obtained by DHCP) to this unit.

### 2.2.3 System Config

- Usage
  1. Start the connection with  in the toolbar.
  2. In addition to the keys, touch operation is also possible by operating the screen part with the mouse.
  3. To finish it, disconnect with  in the toolbar.

For details on how to use it, go to “Help” “Contents” in the drop-down menu to display online help.

-  While the analyzer is remotely connected you cannot control the analyzer physically by the buttons or touch panel. Please disconnect the remote connection for the operation.

## 11.2 Data Conversion Software

The attached CD includes the utility software that converts the communication data captured by this analyzer into a format that can be handled by Wireshark .

In addition to converting DT files in a PC (moved from the analyzer by using external storage), it can start/stop of online monitoring and import of data from the memory of analyzer by connecting it with the PC via USB, LAN, or WiFi (supported model only).

### ■ Preparation

1. Copy lepcapcvt .exe from the lepcapcvt folder in the attached CD to a suitable folder on your computer.
2. Start the software and select the format to convert to from “pcap” and “pcap-ng”. (By the pcap format, the time stamp accuracy that can be handled is 1 μsecond. If you want to handle more accurate time stamps, select pcap-ng.)

### ■ Conversion of DT files moved to PC via external storage

1. Connect the external storage that has the DT file (measurement data) to the PC, and specify the folder with “Folder”.
2. Select the file to be converted with “File list” and press “Start conversion” to convert.
3. A file with the extension pcap or pcapng with the file name (same name of the unconverted file) will be created in the same folder. If there is already a pcap/pcapng file with the same name, it will be overwritten.
4. If you want to see the contents immediately after conversion, check “Open Wireshark” to open the file with Wireshark.

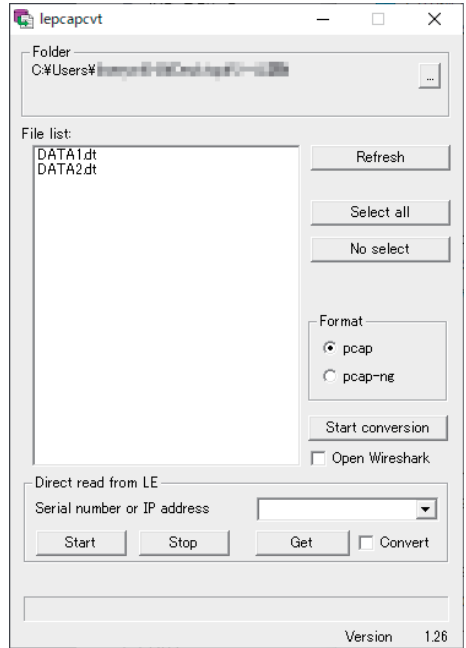

■ Start/stop of remote measurement and data acquisition

1. Specify the target analyzer in “Serial number or IP address”.

When you operate the analyzer connected via USB, enter the serial number of it (written on the back of the main unit).

When connected via LAN or Wi-Fi (supported model only), specify the IP address of it.

If you have changed the port number of analyzer, input “: port number” after the IP address. (Example “192.168.4.1:10102”)

2. Press “Start” to switch to online monitor mode and start measurement. Settings cannot be configured in this function, thus set them in advance on the analyzer side.
3. Press “Stop” to stop the measurement.
4. Press “Get” to import the monitor data in the memory of the analyzer to the PC. When the import is completed, specify the file name and save it.
5. If you have checked “Convert”, the imported file will be converted immediately. If you also check “Open Wireshark”, the file will be opened with Wireshark as it is.

For details on how to use the software, see readme.txt included in the CD-ROM attached to the product.



In order to use the Open Wireshark function, Wireshark must be installed on your PC in advance.

## 11.3 Capture data files while measuring

### “LE file downloader”

“LE file downloader” captures the communication log files saved in the storage device using the auto save function and send them to the PC via LAN or Wi-Fi. This tool is useful to capture the communication log files which has the time stamp around the time when a communication failure occurred, and to analyze the target data using the Wireshark.

-  “LE file downloader” transfers only the measurement data files with the name of “#nnnnnnn.DT” (n is a sequential number starting from “0”) saved by the auto save function.

### How to use

- Download and unzip the “LE file downloader (lefiledownload.exe)” of ver.1.04 or later from LINEEYE website to an appropriate folder on the PC. No installation required.
- Make sure that the analyzer and PC are connected LAN or Wi-Fi.

#### 2.2.3 System Config Network

- Execute the auto save function.
- Double-click the “lefiledownload.exe” and enter the IP address and port number of the analyzer, and click “Connect”.
- The communication log files saved by the auto save function are listed on the window. Click “Update list” to display the latest list.

#### 2.2.2 Record Control Auto Save Function

- Click [  ] to specify the saving destination, and select the communication log file to be imported to the PC referring to the time stamp of the file.

 The communication log file in saving process by the auto save function cannot be downloaded.

- Click “Download” to start transferring to the specified save destination via LAN or Wi-Fi. It may take 1 minutes or more to transfer a 16Mbyte file, depending on the load of the analyzer and the radio wave condition.
- Convert the downloaded communication log files using the “Pcap conversion software (lepcapcvf)” of v1.28 or later. It is possible to analyze data using the free software, such as the Wireshark.

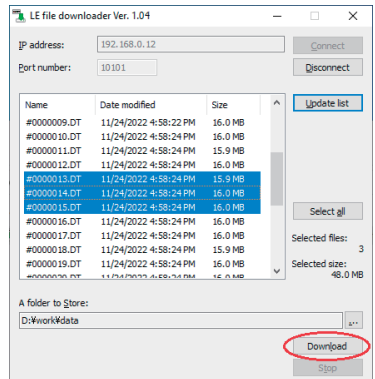
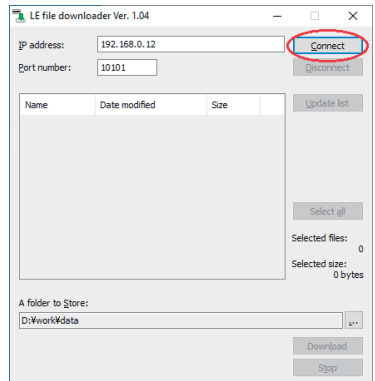

## 11.4 PC Remote Control Library

---

The libraries for Windows are available to make a user application software which remotely controls the analyzer from a PC. The library can be downloaded from LINEEYE website.

- For Windows

Windows 11/10/8.1, VC++6.0 and VC++.NET are supported.

Above operating environment is confirmed by our environment and we do not guarantee a correct operation.

# Chapter 12 Printout Function

Measurement data can be printed out on a printer.

You can also print a hard copy, which outputs the image displayed on the screen to the printer as it is. Tap “File Manager” at the bottom of the top menu screen to move to the “File Manager” that displays the directory list of the connected storage or the “Printer Management” that configures printout settings.

Every time you tap “Device Change” or “File Manager” at the bottom of each screen, it switches between “File Manager” of the connected storage and “Printer Management”.

## 12.1 How to Connect to a Printer

Connection with the dedicated printer SM4-31W (option) is via USB or wireless LAN.

- When using the printer via USB  
Connect the USB port of this analyzer and the printer with a USB cable.  
You can check the status of the USB connection by checking the status of the USB connection on the “Printer Management”.
- When using the printer via wireless LAN  
Connect this machine and printer to the same access point, etc., or set the printer's Wi-Fi setting to the Direct mode to connect this analyzer.  
Set the IP address and port number set for the printer on the “Printer Management”.  
For the printer's Wi-Fi settings, refer to the printer's manual, etc.

## 12.2 Hard Copy of Screen Display

Select USB printer or WLAN printer for Screenshot save to in Display/Power tab of System Config. Press [SHIFT]+[ESC] on the screen you want to output and then the printing will start.

Hard copy print example

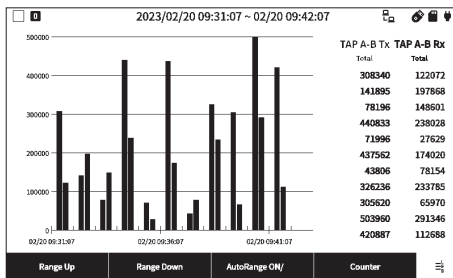

## 12.3 Printout of Measurement Data

When you press "Print" on the printer management screen, a dialog will appear.

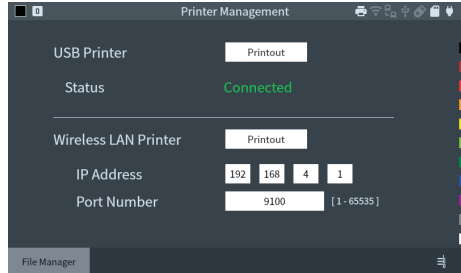

Specify Number of Pages, Number of Lines, etc. in the dialog that appears and press OK. Then the printing will start.

The options in the dialog are the same as those described in the section on Export Data in 9.2 File Management Function.

However, the maximum output is limited to approximately 300 lines for data part.

\* Only measurement data that supports text output can be printed.

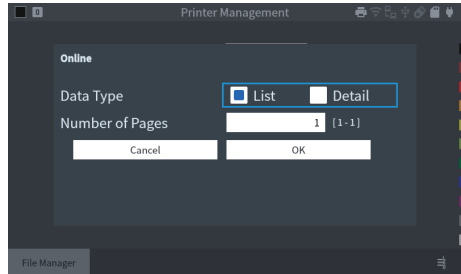

### Printing Example of Data

#### ◆ List Data

```
*=[LE-8600X]====[2023-03-06 15:36:50]=*
* Model      : LE-8600X      *
* Version    : 1.05.00      *
* Extension  : SB-10GE      *
* Serial No. : 99999999     *
* Start time : 2023-03-06 15:35:50 *
* Stop time  : 2023-03-06 15:36:29 *
*-----*
* PROTOCOL: LAN             *
*-----*

-----Time--Len-P---Source-----Destination---Protocol
35:52.671588  66 B 192.168.0.14 192.168.0.47 TCP
35:52.671991  66 A 192.168.0.47 192.168.0.14 TCP
35:52.672159  60 B 192.168.0.14 192.168.0.47 TCP
35:52.675590  584 A 192.168.0.47 192.168.0.14 TCP
35:52.716897  60 B 192.168.0.14 192.168.0.47 TCP
35:52.749521  80 B 192.168.0.14 192.168.0.47 TCP
35:52.749553  60 A 192.168.0.47 192.168.0.14 TCP
35:53.213522  1478 B 192.168.0.14 192.168.0.47 TCP
35:53.213602  60 A 192.168.0.47 192.168.0.14 TCP
35:53.215931  134 B 192.168.0.14 192.168.0.47 TCP
35:53.215960  60 A 192.168.0.47 192.168.0.14 TCP
35:53.295903  710 A 192.168.0.47 192.168.0.14 TCP
35:53.305719  70 B 192.168.0.14 192.168.0.47 TCP
35:53.305790  60 A 192.168.0.47 192.168.0.14 TCP
36:23.920244  118 B 192.168.0.14 192.168.0.47 TCP
```

#### ◆ Detail Data

```
*=[LE-8600X]====[2023-03-06 15:36:57]=*
* Model      : LE-8600X      *
* Version    : 1.05.00      *
* Extension  : SB-10GE      *
* Serial No. : 99999999     *
* Start time : 2023-03-06 15:35:50 *
* Stop time  : 2023-03-06 15:36:29 *
*-----*
* PROTOCOL: LAN             *
*-----*

-----Time--Len-P---Source-----Destination---Protocol
35:52.671588  66 B 192.168.0.14 192.168.0.47 TCP
Ethernet II
Destination: 88-FD-15-02-CC-F0
Source: C0-3F-D5-A4-10-54
Type: IP (0x0800)
FCS: B6 31 07 76
Internet Protocol
Version: 4
Header length: 20
Service type: 0x00
Total length: 52
Identification: 0xCF3D (53053)
Flags: 0x02
Fragment offset: 0
Time to live: 128
Protocol: TCP (0x06)
Header checksum: 0xA9F8 - correct
Source: 192.168.0.14
Destination: 192.168.0.47
Transmission Control Protocol
Source port: 1366
Destination port: ssh (22)
Sequence number: 165437364
Acknowledgment number: 0
Data offset: 32
```

# Chapter 13 Specifications and Maintenance

## 13.1 Specifications of Function and Hardware

Interface	SFP+ 2ports. A and B (optional SFP/SFP+ modules to be connected) 10Gbe such as 10GBASE-T/SR/LR/ER, 1GbE and 2.5GbE.
Memory/Internal Storage	Capture memory: 1Gbyte (96byte to 12320byte for 1 frame) Internal storage: 500Gbyte.
On-line Monitor Function	Recording and real-time display of Ethernet frames flowing between SFP+ ports A and B
Frame Size	60byte to 9Kbyte
Capture performance	About 10Gbps <sup>*1</sup>
Time stamp	The reception time is added as timestamp data for each received frame. Resolution: 8n seconds / 1u seconds / 10u seconds can be selected.
Data display/operation	2Scroll display, 2-split comparison display, jump operation to specified screen, mark jump operation
Display	Supported protocols : IPv4, ARP, ICMP, TCP, UDP, DHCP, EtherCAT, IPv6, ICMPv6
PcapNG Conversion	Measurement data can be converted and saved to a PcapNG format file.
CSV Conversion	Measurement data can be converted and saved to a CSV format file.
TXT Conversion	Measurement data can be converted and saved to a TXT format file.
Filter Function	Can monitor only the specific frames that match one or two specified conditions.
Trigger Function	Condition: When the specified frame is received or when the external TTL signal changes. Action: Automatically stops the monitor, counts the number of matching conditions, outputs an external TTL signal.
Search Function	From the measured data, it can search, cue, and count only the specific frames that match the specified conditions.
SFP Module Information Display Function	Displays detailed information of the SFP/SFP+ module inserted to the measurement port.
Statistical Analysis Function	It takes statistics of two frame counter values at specified intervals (2 to 240 seconds, 1 to 240 minutes) and can display the graph display, all frame counter values, and data rate in real-time.
PG Function	From the SFP+ port A and B it can output arbitrary packet set in 16 transmission data tables (total 32k data) of each port at arbitrary wire rate.
Ping Function	Can issue a PING command from SFP+ port A to display the number of responses and response time (current value, maximum value, minimum value, average value).
Port Blink Function	The connection destination of the cable can be confirmed by periodically blinking the link LED of the hub port to which the cable of SFP+ port A is connected.
Capture Slice Function	Records only the first 60 bytes of LAN frames flowing between SFP+ ports A and B
Auto save Function	The contents of the capture memory (monitored data) can be automatically saved as a communication log file to the built-in SSD or to a storage device such as USB memory / SDHC card <sup>*2</sup>
Additional Functions	Time synchronization function by PPS signal of GNSS or external PPS signal, auto backup function, time specified automatic RUN/STOP function, power-on automatic RUN function
Display	7 inch TFT color LCD with capacitive touch panel
Line Status LED	11 LEDs always display the connection status of SFP+ port A and B

LAN Port	RJ45 connector, 1000BASE-T Ethernet: IEEE 802.3 for PC connection
USB Device Port	Type-C connector, SuperSpeed transfer supported. For PC connection.
USB Host Port	Standard A connector, SuperSpeed transfer supported. For external storage (USB memory/SSD).
SD Card Slot	For standard size SD / SDHC memory cards, compliant with SD Association standard.
External I/O terminal	4-pin connector for TTL level trigger input/output signals
GPS Antenna Connector	SMA( female ) connector
PPS Signal Connector	SMA( female ) connector
Wi-Fi interface *3	IEEE802.11b/g/n frequency range: 2412MHz to 2484MHz Transmission power 802.11b: +18.5dBm 802.11g: +18.0dBm 802.11n: +17.0dBm
Printout function	Measurement data can be output to printer. Screen image can be output to printer.
Power	Attached AC adapter or lithium-ion secondary battery (model number: P-26LW2) Battery drive time: 2 hours *4
Ambient Temperatures	In operation : 0 to 40 degree Celsius, In storage : -20 to 50 degree Celsius
Ambient Humidity	20 to 85%RH (No condensation)
Standard	CE ( class A )
Size & Weight	234(W)×186(D)×44(H) mm, Approx. 990g

\* 1 Capture loss may occur if a large number of short packets are continuously sent to the target line of capturing or if packets are sent simultaneously in both directions with a high load.

\* 2 For high-traffic lines, part of the communication frame is not recorded in the storage and capture loss may occur.

\* 3 LE-8600XR only. For PC connection. The “Wi-Fi module” used for the product conforms to SRRRC(China), FCC (USA), CE (EU), TELEC (Japan), KCC (Korea), ISED (Canada), NCC (Republic of China), however, as the “product” the Wi-Fi function is available only in Japan, USA, Canada, and EU nations in compliance with RE directive (2014/53/EU).

\* 4 According to our test conditions assuming a normal usage situation.

## 13.2 Shortcut Keys

The shortcut key operation similar to the operation by the menu number of the conventional model is available. By pressing [0] to [F] after [MENU], you can move to the frequently used setting screen.

Shortcut key	Setting display	Remark
[MENU], [0]	filter	
[MENU], [1]	Interface	
[MENU], [2]	Trigger	
[MENU], [3]	Online monitor	(*)
[MENU], [8]	Ping	
[MENU], [9]	PG	
[MENU], [A]	Except for some pages, by these operations, the functions in the touch operation guide at the bottom of the screen will be executed. (Assigned to A, B, C, D, E from the left of the guide)	(*)
[MENU], [B]		
[MENU], [C]		
[MENU], [D]		
[MENU], [E]		

- ☰ If the transition destination setting screen is not valid for the current function or operation mode, such as pressing the [MENU] or [9] key in online monitor function, the operation will be ignored.
- ☰ Please note that the shortcut key operation with (\*) is different from the operation by the menu number of the conventional model.

## 13.3 Measurable Interface Expansion

By using the option for measurement expansion, you can expand the communication target to be measured.

### ■ Exchange the board

Remove the standard interface sub board and replace it with the optional interface sub board.

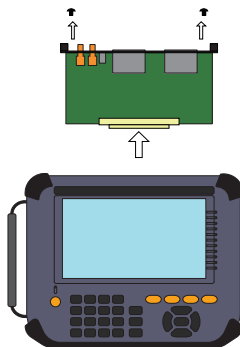

### ■ Firmware

The firmware of inserted interface sub-board starts automatically. If the firmware is not the latest one, the analyzer runs in the firmware update mode. In this case, please update the firmware to the latest one.

## 13.4 Factory reset

By the Factory reset operation, you can initialize the internal status of this analyzer and return the settings to the factory settings.

- How to

Tap “Factory reset” on the “Version” tab of “System Settings”. If you tap “OK” in the confirmation message, the main unit will automatically shut down and the settings will be initialized when you boot it next time.

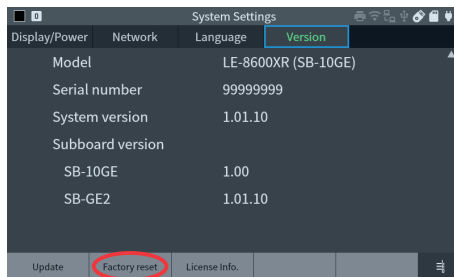

## 13.5 Firmware Update

This unit can update the firmware / recover the entire system.

The latest firmware file and system recovery file can be downloaded from LINEEYE website.

[https://www.lineeye.com/html/download\\_update.html](https://www.lineeye.com/html/download_update.html)

Download it to an easy-to-find folder on your computer, unzip it, and check the firmware file (extension: FW3) or system recovery file (extension: FWR).

The downloaded file can be written to the analyzer in the following ways.

- 1) Copy the firmware file or system recovery file to the storage device (USB memory or SDHC card).
- 2) Move from “System Settings” to “Version” and then tap “Update” to restart the device in the update mode.
- 3) After rebooting, the boot logo will be displayed and then the firmware update mode screen will appear.
- 4) Insert the storage device to which you copied the firmware file or system recovery file in the analyzer.
- 5) On the update mode screen, tap “Update”.
- 6) Select the firmware file or system recovery file.
- 7) For system recovery files, a message warning that the settings will be initialized is displayed.
- 8) It displays the message when the firmware update or system recovery is complete. Tap “OK” to restart.
- 9) To check the updated firmware version, move from “System Settings” to “Version”.

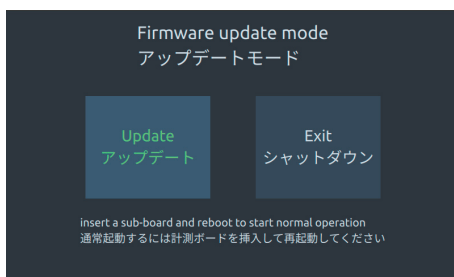

## 13.6 Trouble shooting

- This section describes how to solve problems when the analyzer does not operate normally.

Problem	Cause / Remedy
Cannot turn on the power. The power turns off immediately.	<ul style="list-style-type: none"> <li>• When operating by the battery, fully charge it.</li> <li>• If the attached AC adapter is connected but it does not improve, it may be broken.</li> <li>• If the power does not turn on, press and hold the power switch for about 1 second.</li> </ul>
Unable to charge Unable to charge enough.	<ul style="list-style-type: none"> <li>• If the power LED (red) is not lit, connect the AC adapter.</li> <li>• It cannot be charged at extremely low or high temperatures. Charge at 5 to 40°C.</li> <li>• If the battery is fully charged but the power runs out shortly, the battery may be dead.</li> </ul>
The backlight turns on but it goes out immediately.	<ul style="list-style-type: none"> <li>• Select the appropriate automatic dimming time of the backlight at the “System Settings” tab of “Display/Power” in the top menu.</li> </ul>
When it starts up, the firmware update screen appears.	<ul style="list-style-type: none"> <li>• Set the sub board securely.</li> <li>• Load the necessary firmware for the optional sub board used at the moment.</li> </ul>
When [RUN] is executed, the previous measurement data disappeared.	<ul style="list-style-type: none"> <li>• Set automatic backup at the “Auto Save” tab of “Record Control” in the top menu.</li> </ul>
The date and time of the time stamp are incorrect.	<ul style="list-style-type: none"> <li>• At the clock display on the top menu set the current date and time before measurement.</li> <li>• If the date and time often go wrong, the built-in lithium battery may have run out.</li> </ul>
Keys does not work.	<ul style="list-style-type: none"> <li>• Key operation is not possible during internal processing such as access to storage device.</li> <li>• Cannot be controlled while connected from a PC.</li> <li>• Try again by disconnecting all cables under measurement.</li> <li>• The response of the key becomes extremely slow when high-speed data (out of specification) is measured.</li> </ul>
Does not work properly. Some of the display is incorrect.	<ul style="list-style-type: none"> <li>• Turn off the power and then turn it on again.</li> <li>• Execute the factory reset (“Factoryreset” at the “Version” tab of “System Settings”). It will return to the factory default condition. Please note that all data will be erased.</li> <li>• If it still does not work, perform the system recovery.</li> </ul>
Line state LED does not light.	<ul style="list-style-type: none"> <li>• Connect the cable correctly.</li> <li>• Check that the SFP module is properly installed.</li> <li>• Check if there is any broken wire or loose connector.</li> </ul>
An SD card cannot be used on the analyzer	<ul style="list-style-type: none"> <li>• Please use optional SD card from LINEEYE.</li> <li>• Please use an SD card within the maximum SD card capacity.</li> </ul>
The Wi-Fi function cannot be used.	<ul style="list-style-type: none"> <li>• Wi-Fi function is available only in Japan, USA, Canada and EU countries.</li> <li>• Check if the Wi-Fi SSID and KEY are set correctly.</li> <li>• Move to a location where radio waves can be easily received.</li> </ul>

Problem	Cause/Remedy
Cannot connected to a computer via the USB port.	<ul style="list-style-type: none"> <li>• Check if the connection is blocked by security softwares.</li> </ul>
Unable to monitor	<ul style="list-style-type: none"> <li>• Is the cable connection and type (cross, straight) correct?</li> <li>• Is the Interface setting correct? Try turning the auto-negotiation on.</li> <li>• Does the Filter setting meet the desired conditions (disable it if not needed)</li> <li>• Try re-inserting the SFP/SFP+ module or cable.</li> </ul>
The PG function does not output data.	<ul style="list-style-type: none"> <li>• Check the above</li> <li>• Check if the Send Table is enabled.</li> </ul>
Unable to use Ping	<ul style="list-style-type: none"> <li>• Adapt the configuration of Ping Opt.,Interface to the target network environment.</li> <li>• Consult with the administrator of the target network.</li> </ul>
Unable to make power off	<ul style="list-style-type: none"> <li>• Unexpected event occurs.</li> <li>• Forced shutdown by pressing and holding the power key.</li> </ul>

## 13.7 Warranty and After service

---



### Warranty

---

- When you face any problems, please contact LINEEYE distributors or LINEEYE
- Warranty

Within a period of 12 months from the date of shipment, LINEEYE warrants that your purchased products (except consumable parts such as the battery and software) are free of charge from any defects in material and workmanship, only when the products are operated in accordance with procedures described in the documents supplied by LINEEYE. If the defects exist during the Warranty period, please send back the products to LINEEYE distributors or LINEEYE. LINEEYE will repair or exchange them at no charge. In this case, the shipping charge will be at your own expense.

The foregoing warranties are the sole warranties given by LINEEYE. Above warranties shall not be applied to the products that have been modified, repaired or altered (except by LINEEYE) or that have been subjected to unusual physical or electrical stress, misuses, abuse, negligence or accidents.

LINEEYE disclaims all other warranties including the warranties of merchantability fitness for some particular purpose and noninfringement of third party right. LINEEYE cannot promise that the software is error free or will operate without any interruption.



### User Registration

---

User registration is required to receive appropriate after-sales support.

Please register as a user using the user registration form on our website.

<https://www.lineeye.co.jp/html/support.html>



### Repair

---

For malfunction, please contact LINEEYE distributors or LINEEYE and tell us following details.

Model	LE-8600X or LE-8600XR
Serial Number	The serial number of 8-digit alphanumerical
Purchase Date	Year, Month, Day
Other	Details of malfunction



### 13.6 Trouble shooting

- Repair during warranty period  
LINEEYE repairs, following the repair instruction.  
Please provide the details of malfunction.
- Repair after warranty period  
LINEEYE will repair the products at our own expense.



## Maintenance parts

---

Maintenance parts such as lithium-ion batteries, attached cables, and AC adapters can be purchased from the store where you purchased the product or from our online shop.

- About recycling of lithium-ion batteries

Please recycle the replaced old battery in accordance with the local laws and regulations of each country.



## After Support

---

Read “FAQ” in our Website or email us.

Please refer to “FAQ” . We also have support by email regarding the technical issue. When you use it, please register your product via our website.

Website : <https://www.lineeye.co.jp/>

## LINEEYE CO., LTD.

4F., Marufuku Bldg., 39-1, Karahashi Nishihiragaki-cho, Minami-ku,  
Kyoto, 601-8468, Japan

Tel : 075(693)0161 Fax : 075(693)0163

URL <https://www.lineeye.com> Email :[info@lineeye.co.jp](mailto:info@lineeye.co.jp)

Printed in Japan

M-B686XE/L