

LINEEYE

Options for LE-8600X/LE-8500X series
CAN/High-speed analog measurement expansion set

SB-C2AN

Instruction Manual

The utility CD attached to the main unit contains an English instruction manual for this expansion kit in PDF format.

《 The 4th edition 2026.06 》

Instruction

Thank you for your purchase of SB-C2AN, To use it correctly, you are advised to read and understand this instruction manual thoroughly. Keep this together with the warranty. If you encounter any problems, you will find helpful information in this manual.



NOTICE

It is prohibited to reprint or duplicate any part of the whole of this instruction manual without prior permission from LINEEYE. The content of this instruction manual and specifications of the products are subject to change without any notice. This instruction manual has been designed and edited with great care to give you all necessary information. If you have any questions, feel free to direct your inquiries to LINEEYE. LINEEYE makes no warranty or guarantee, either expressed or implied with respect to its quality, performance, merchantability, or fitness for a particular purpose. LINEEYE shall not be liable for direct, in-direct, special, incidental, or consequential damages resulting from any defect in the product. The warranty and remedies set forth above are exclusive and in lieu of all others.



USER LIMITATION

This product has been developed for the purpose of using as an analyzer only. When you use this product with the following devices that are required to function with a high degree of reliability, safety and accuracy, use it under considering the safe design of the system in order to maintain reliability and safety for that system; *Devices that are directly related to transportation such as airplanes, trains, cars etc. *Devices for crime prevention and disaster privension. *Each kind of safety devices and so on. This product has not been developed for the use that needs exclusivity high reliability and safety: aerospace apparatus, trunk communication apparatus, nuclear control apparatus, medical apparatus related with life maintenance etc. Therefore, do no use for those purposes.

Safety Information

Read this first !!

This Safety Information includes the following important information in order to not only have you learn the right way to use the analyzer, but also prevent you from causing damage to people and property. Before using, please read the main contents after you understand the following symbols & marks.

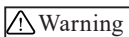

Warning

Should the device be used without following these symbols, there is a possibility of accidents, such as a death or a serious injury, occurring.

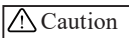

Caution

Should the device be used without following these symbols, there is a possibility of accidents, such as an injury^(*), and material damage^(**) occurring.

*1 “Injury” indicates injury, burn and electric shock, or the like which does not require hospitalization or the extended hospital visit.







*2 “Material damage” indicates damage related to a house, a building, furniture, apparatus, livestock or a pet.







Prohibition



The necessary

|  Warning | |
|---|--|
|  | <ul style="list-style-type: none">Do not disassemble, modify or repair the line monitor This may result in an injury, electric shock, and ignition. |
|  | <ul style="list-style-type: none">Do not put the analyzer in fire or heat them. This may result in a injury and fire due to overheating or explosion. |
|  | <ul style="list-style-type: none">Do not use the line monitor if there is inflammable gas. This may result in ignition and explosion. |
|  | <ul style="list-style-type: none">Turn off the power of analyzer and unplug the cables immediately when emanating smoke, odor or sound. Continuous use may result in an electric shock, injure or ignition. |
|  | <ul style="list-style-type: none">Turn off the power and unplug the line monitor immediately when liquid or foreign substance gets into the line monitor. Continuous use may result in ignition, electric shock and malfunction. |

 Caution

| | |
|--|---|
|  | <ul style="list-style-type: none">● Do not touch the line monitor with wet hand. This may result in an electric shock and malfunction. |
|  | <ul style="list-style-type: none">● Do not give a strong impact on the product, such as dropping and crashing. |
|  | <ul style="list-style-type: none">● Do not leave the analyzer in the following conditions.<ul style="list-style-type: none">▪ Strong magnetic field, static electricity or dusty place.▪ Temperature and humidity above the specification or where dew condensation appears.▪ Not flat, or shaking place.▪ Place with leaking water or electricity.▪ Place affected by direct sun or near the fire. <p> Please do not leave the analyzer in the car during the summer.</p> |
|  | <ul style="list-style-type: none">● Do not use at the following situations. The radio wave by the analyzer may cause trouble.<ul style="list-style-type: none">▪ Near a medical device such as cardiac pacemaker or hearing aid.▪ Near an automatic controller such as fire-alarm box or automatic door.▪ Near a microwave, high-level electronics, TV, or radio.▪ Near a wireless station for mobile communications or a specified low power radio station. |

CONTENTS

| | |
|---|-----------|
| Safety Information | 1 |
| Chapter 1 Before Using the Product | 5 |
| 1.1 Overview | 5 |
| 1.2 Unpacking..... | 5 |
| 1.3 Insert the interface board | 6 |
| 1.4 Installation of Firmware..... | 6 |
| Chapter 2 Basic Operation..... | 7 |
| 2.1 Panel Description | 7 |
| 2.2 Operation..... | 7 |
| 2.3 Line State LEDs | 8 |
| 2.4 Common functions..... | 8 |
| 2.5 Measurement mode..... | 9 |
| 2.6 Preparation of CAN/CAN FD measurement..... | 10 |
| 2.7 Preparation of High-speed analog measurement..... | 13 |
| 2.8 Preparation of analog signal measurement for multi channels | 17 |
| 2.9 Preparation of measuring the external trigger | 22 |
| 2.10 Preparation of GPS signal measurement and GPS/PPS synchronous | 23 |
| Chapter 3 Online Monitor Function | 25 |
| 3.1 Outline | 25 |
| 3.2 Start measuring | 25 |
| 3.3 End of measurement..... | 26 |
| 3.4 Change displays..... | 26 |
| 3.4.1 Frame display..... | 27 |
| 3.4.2 GPS data display | 29 |
| 3.4.3 Timer/ Counter display..... | 30 |
| 3.5 Jump function..... | 30 |
| 3.6 Search function..... | 31 |
| 3.7 Split display (display two separated screen) | 33 |
| Chapter 4 Analog measurement function..... | 34 |
| 4.1 Outline | 34 |
| 4.2 Analog display..... | 35 |
| 4.2.1 Analog value display | 35 |
| 4.2.2 Analog graph display | 36 |

| | |
|--|-----------|
| Chapter 5 Analog wave monitor function | 37 |
| 5.1 Outline | 37 |
| 5.2 Settings | 37 |
| 5.3 Start | 39 |
| 5.4 Analog waveform display screen | 39 |
| 5.5 Digital waveform display screen..... | 40 |
| Chapter 6 Manual Simulation Function..... | 41 |
| 6.1 Overview | 41 |
| 6.2 Settings | 41 |
| 6.2.1 CAN main table summary screen..... | 42 |
| 6.2.2 CAN FD data editing | 45 |
| 6.2.3 CAN subtable summary screen | 46 |
| 6.3 Start | 49 |
| 6.4 End..... | 49 |
| Chapter 7 Trigger Function..... | 50 |
| 7.1 Overview..... | 50 |
| 7.2 Settings | 50 |
| 7.3 Display screen | 58 |
| 7.4 Timer/Counter function..... | 59 |
| Chapter 8 Translation function | 61 |
| 8.1 Outline | 61 |
| 8.2 Setting | 61 |
| 8.3 Screen display | 65 |
| 8.4 J1939 Translation..... | 67 |
| Chapter 9 Save and Load of the Data | 68 |
| 9.1 Export data function..... | 68 |
| Chapter 10 Printout function | 71 |
| Chapter 11 Specification | 72 |
| Chapter 12 After Support and Maintenance..... | 76 |
| 12.1 Factory reset | 76 |
| 12.2 Probe compensation | 76 |
| 12.3 Warranty and After service | 79 |

Chapter 1 Before Using the Product

1.1 Overview

SB-C2AN is an interface expansion set inserted into LE-8600X/ LE-8500X series to measure CAN (ISO 11898-1), CAN FD (ISO11898-1: 2015), and analog value. Once it is equipped with LE-8600X/ LE-8500X series, it becomes the stand-alone analyzer, which can measure CAN/ CAN FD (in-vehicle communication) and analog data.

■ Features

- Sets up easily by simply replacing the interface board.
- Supports CAN FD up to 5Mbps.
- Monitors 2 channels simultaneously in real time.
- Captures specific frames by ID filter and trigger function.
- Simulates both CAN/ CAN FD registered in different transmission cycles.
- Measures high-speed analog waveform up to 100M samples/sec.
- Records 8 channels of voltage along with communication data for a long time using the attached analog pod (OP-8AH).
- Measures high-precision analog value and temperature using the optional analog pod (OP-8AT).
- Records GPS positioning information compatible with submeter-level positioning reinforcement service.

1.2 Unpacking

When you unpack the product, make sure of the following.

The product has not been damaged during the transit. There is not any defect on the appearance.

You have received all the standard accessories listed below.

- | | |
|--|---|
| • Interface board | 1 |
| • Dsub 9pin branch cable for CAN/CAN FD. | 1 |
| • Passive probe (BNC connector) | 2 |
| • Analog pod for high-speed/ high-voltage (OP-8AH) | 1 |
| • Connection cable | 1 |
| • Quick start guide | 1 |
| • Warrant | 1 |

Please contact your LINEEYE distributors if you find any damage to the product caused by transportation, or if there are accessories lacking.

Option

- Analog pod for measuring high-precision analog value and temperature (OP-8AT)
- BNC test clip cable (LE-BNC1040)
- Dsub 9pin terminal block (LE-9TB)
- OBD2-Dsub 9pin cable (OBD2-DB9-09B)

1.3 Insert the interface board

Exchange the standard interface board to SB-C2AN.

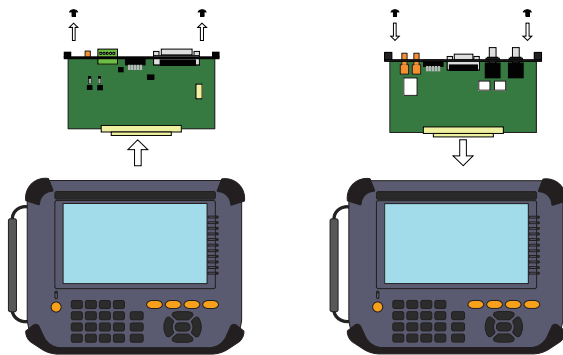

- 1) Turn off the analyzer.
- 2) Screw off M3 screws on the interface board of analyzer.
- 3) Take the board off pulling the handles of the interface board.
- 4) Insert the interface expansion board (SB-C2AN) into the slot completely
- 5) Screw it on using M3 screws.

1.4 Installation of Firmware

An applicable firmware is necessary to use SB-C2AN. If you purchase LE-8600X/ LE-8500X series before releasing the sale of SB-C2AN, update the firmware referring the instruction manual analyzer. Download the firmware file from LINEEYE webpage.

https://www.lineeye.com/html/download_update.html

Chapter 2 Basic Operation

2.1 Panel Description

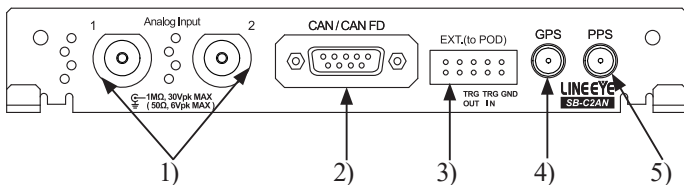

| | |
|----|---|
| 1) | High-speed analog measurement ports (2ch) |
| 2) | CAN/ CAN FD measurement port |
| 3) | External trigger/ Expansion analog measurement port |
| 4) | SMA (female) connector for GPS antenna |
| 5) | SMA (female) connector for PPS device |

2.2 Operation

■ Shortcut keys

| Shortcut keys | Settings |
|---------------|---|
| [MENU] , [0] | CAN Configuration |
| [MENU] , [1] | Analog input option |
| [MENU] , [2] | Trigger |
| [MENU] , [3] | Translation |
| [MENU] , [4] | Wave Monitor Option |
| [MENU] , [9] | Manual Option |
| [MENU] , [A] | |
| [MENU] , [B] | Executes the operation shown on the bottom of analyzer. (Assigned A, B, C, D, E from the left side) |
| [MENU] , [C] | |
| [MENU] , [D] | |
| [MENU] , [E] | |

Invalid command will be ignored. For example, pressing [Menu]+[9] while operating the Online monitor function.

2.3 Line State LEDs

Descriptions of LEDs on the right side of analyzer are following.
Tap the right bottom to display/hide the descriptions of LEDs.

| Number | Description | Level | Light |
|--------|--------------|-----------|-------|
| CAN1 | CH1 CAN data | Dominant | ON |
| | | Recessive | OFF |
| CAN2 | CH2 CAN data | Dominant | ON |
| | | Recessive | OFF |

2.4 Common functions

“File manager”, “Record control”, “System Config” and “Day &Time display” are same as LE-8600X/LE-8500X series. Please refer to the “Basic operation and set-up” in the instruction manual or LE-8600X/LE-8500X series.

2.5 Measurement mode.

There are “Online”, “Analog”, and “Manual” mode.

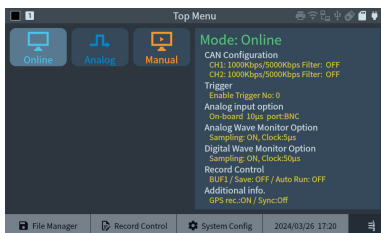

Online :

Online monitor function.

It measures CAN, CAN FD and analog value.

Tap “Mode”->“Online” from top menu.

Analog :

Online monitor function.

It measures analog value only.

Tap “Mode”->“Analog” from top menu.

Manual :

Manual simulation function.

It transmits CAN/CAN FD frames ^(*) and measure CAN/CAN FD and analog value as well.

Tap “Mode”->“Manual” from top menu.

*1: CAN/CAN FD measurement port acts as a device and returns ACK automatically.

■ Setting items

Setting items differ from measurement mode.

| Settings of each mode | | Online | Analog | Manual |
|-----------------------|--|--------|--------|--------|
| CAN Config | Sets communication conditions and ID filter for CAN/CAN FD. | ● | | ● |
| Analog Config | Sets measurement condition for Analog Input and expansion pods (to POD). | ● | ● | ● |
| Manual Opt. | Sets the transmission data of CAN/CAN FD. | | | ● |
| Trigger | Sets the trigger conditions. | ● | ● | ● |
| Translation | Sets the conditions of translation display. | ● | | ● |
| Wave Opt. | Sets the condition of analog/digital waveform. | ● | ● | ● |

2.6 Preparation of CAN/CAN FD measurement

Online monitor function can measure 2 channels of data simultaneously.
Manual simulation function can transmit data from either Ch1 or Ch2.

■ Connection

Connect the CAN/CAN FD port (Dsub9pin) of analyzer and the target devices. Use the attached monitor cable after confirming the specification of pin assignment.

< Setting of Termination >

Dsub 9pin branch cable

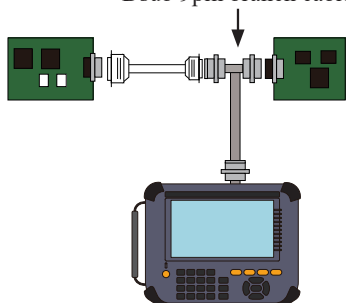

When the signal arrangement of the DSUB 9-pin is different, please use a conversion terminal block, etc.

Terminal block for DSUB 9-pin (screwless)
Sold separately (optional).
Model number: LE-9TB



Pin assignment of CAN/CAN FD measurement port

| Dsub9pin female inch screw #4-40 | | | | |
|----------------------------------|----------|----------------------------|--------|--------------------|
| Pin | Signal | Input/Output ^{*1} | | Description |
| | | Online | Manual | |
| 1 | CAN Low | I | I/O | Ch2 CAN Bus Signal |
| 2 | CAN Low | I | I/O | Ch1 CAN Bus Signal |
| 3 | GND | - | - | Signal ground |
| 4 | - | - | - | No use |
| 5 | - | - | - | No use |
| 6 | GND | - | - | Signal ground |
| 7 | CAN High | I | I/O | Ch1 CAN Bus Signal |
| 8 | CAN High | I | I/O | Ch2 CAN Bus Signal |
| 9 | - | - | - | No use |

*1: "I" is an input to the analyzer. "O" is an output from the analyzer.

The jumper pin makes it possible to connect the terminator in the CAN communications.

CH1 (R side short) : Connect the terminator (120 Ohm) to CAN1 port.

CH2 (R side short) : Connect the terminator (120 Ohm) to CAN2 port.

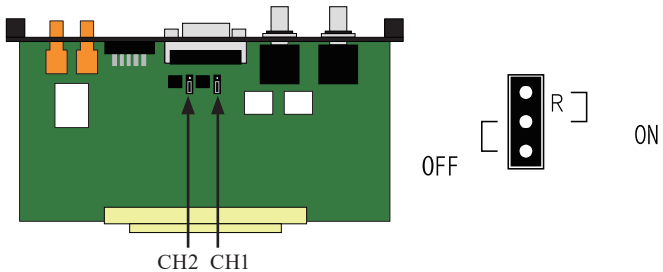

■ Setting

Set the CAN/CAN FD measurement settings from “Online” or “Manual” ->“CAN Config”.

Set the Ch1 from the tab of “CAN1” and Ch2 from the tab of “CAN2”.

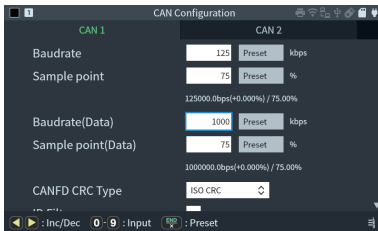

◆ Baudrate, Sample point

Set the baudrate and sample point (bit) of target devices. Select the preset value or input any number. The appropriate value according to the performance of analyzer will be displayed below the sample point. The analyzer may not be able to monitor if the baudrate and sample point are not in the appropriate range. For CAN FD, set the “Baudrate (Data)” and “Sample point (Data)” as well.

◆ CAN FD CRC type

For CAN FD, select “ISO CRC” or “non-ISO CRC”.

◆ ID Filter

To capture the specific frame only, valid the “ID filter”. Set the ID in decimal and “don’t care” by [X].

Example of ID setting:

<CAN Standard ID=24Dh>

| |
|----------------|
| ID (0x24D) |
| 010 0100 1101b |

ID Filter

| | | | | | | | | | | | | | | | | | | |
|----------|----|----|----|----|----|----|----|----|----|----|----|---|---|---|---|---|---|---|
| | 10 | 9 | 8 | 7 | 6 | 5 | 4 | 3 | 2 | 1 | 0 | | | | | | | |
| Standard | 28 | 27 | 26 | 25 | 24 | 23 | 22 | 21 | 20 | 19 | 18 | | | | | | | |
| | 0 | 1 | 0 | 0 | 1 | 0 | 0 | 1 | 1 | 0 | 1 | | | | | | | |
| Extended | 17 | 16 | 15 | 14 | 13 | 12 | 11 | 10 | 9 | 8 | 7 | 6 | 5 | 4 | 3 | 2 | 1 | 0 |
| | 0 | 0 | 0 | 1 | 0 | 1 | 1 | 1 | 0 | 0 | 1 | 1 | 0 | 1 | 1 | 1 | 1 | 0 |

* In the case of above setting, the expansion ID=09340000h - 0937FFFFh also become the target.

<CAN expansion ID=9345CDEh>

| | |
|---------------------------------------|-------------------------|
| ID (0x9345CDE) | |
| 0 1001 0011 0100 0101 1100 1101 1110b | |
| Base ID (0x24D) | Expansion ID (0x5CDE) |
| 010 0100 1101b | 00 0101 1100 1101 1110b |

ID Filter

| | | | | | | | | | | | | | | | | | | |
|----------|----|----|----|----|----|----|----|----|----|----|----|---|---|---|---|---|---|---|
| | 10 | 9 | 8 | 7 | 6 | 5 | 4 | 3 | 2 | 1 | 0 | | | | | | | |
| Standard | 28 | 27 | 26 | 25 | 24 | 23 | 22 | 21 | 20 | 19 | 18 | | | | | | | |
| | 0 | 1 | 0 | 0 | 1 | 0 | 0 | 1 | 1 | 0 | 1 | | | | | | | |
| Extended | 17 | 16 | 15 | 14 | 13 | 12 | 11 | 10 | 9 | 8 | 7 | 6 | 5 | 4 | 3 | 2 | 1 | 0 |
| | * | * | * | * | * | * | * | * | * | * | * | * | * | * | * | * | * | * |

2.7 Preparation of High-speed analog measurement

It is possible to measure the analog value of BNC connectors on the high-speed analog port, or analog value of CAN Ch1 signal on the CAN/CAN FD port.

Analog waveform monitor function and analog measurement (logger) function can be used.

■ Analog wave monitor function

It records the waveform at trigger timing (max at 100MHz sampling rate) and performs as an oscilloscope.

 Chapter 5 Analog wave monitor function

■ Analog measurement (logger) function

It records the analog input value for a long time with time stamp for a specific cycle.

 Chapter 4 Analog measurement function

■ Connection

Connect the high-speed signals to the BNC analog ports.

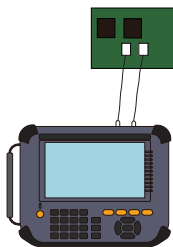

Use the attached passive probes (P7100) or optional BNC test clips to connect.

- * When using an oscilloscope probe, we recommend using it on the 1x side.
- * To use the passible probe as “x10”, adjusting is necessary.

 12.2 Probe compensation

When using the passive probe as x10, measured value will be 1/10 of actual voltage.



Do not connect to the AC100V. It may cause the electric shock and burning.

■ High-speed analog measurement setting

< To use the analog wave monitor function >

Tap “Wave Opt.” in the setting items in each measurement mode to display the waveform monitor option screen, and configure settings on the “Analog” tab.

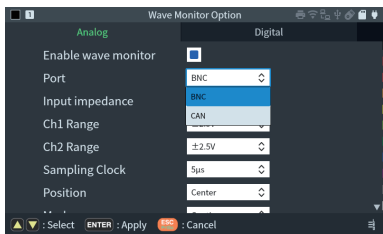

◆ Enable wave monitor

Mark on the box to use the analog wave monitor function.

◆ Port

Select “BNC” to measure BNC connector (analog input 1, 2).

Select “CAN” to measure CAN high or CAN low on the Ch1 of CAN/
CAN FD port.

◆ Input impedance

For BNC connector, it is possible to change the input impedance from $1\text{M}\Omega$ to 50Ω .

*When selecting 50Ω , do not apply the power more than $\pm 6\text{V}$.

◆ CH1 Range/CH2 Range

Select the range of voltage level from $\pm 2.5\text{V}$, $\pm 5\text{V}$, $\pm 12\text{V}$ or $\pm 24\text{V}$.

◆ Sampling Clock

Select the range of sampling clock. There are 12 selections from 10ns (100MHz) to 50µs (20KHz).

Selected value should be 1/100 to 1/20 of the target waveform cycle.

◆ Trigger position

Set the trigger position in the sampling memory.

Before : Capture a large amount of data before the trigger occurrence.

Center : Capture the same amount of data before the trigger occurrence and after the trigger occurrence.

After : Capture a large amount of data after the trigger occurrence.

◆ Trigger mode

Single : Capture the waveform when it matches the trigger condition at the first time.

Continuous : Display data at the trigger waiting for matching, and data after matching the trigger conditions. Even the trigger do not match with the conditions for the specific time, it still displays the waveform.

◆ Trigger factor

Select the trigger factor from “analog level” or “online”.

Analog level : The voltage value of analog input is the trigger factor.

Online : The trigger factors set in the monitor function of CAN/CAN FD are used.

◆ Trigger number

Select the trigger number when the “Trigger factor” is “Online”.

 Chapter 7 Trigger Function

◆ Channel/ slope/ level

Set the status of analog input as the trigger factor. (when “Trigger factor” is “Analog”)

◆ Calibration pulse (for probe)

Output the calibration signal for the passible probe (1kHz square wave) from the trigger output terminal. Valid the function only calibration is necessary for the passible probe.

 12.2 Probe compensation

< To use the analog measurement (logger) function >

Tap “Analog Config” for each mode, Set “Analog measurement” on the analog input option screen to “On-board”.

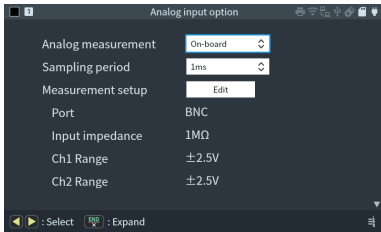

◆ Sampling period

Select the sampling period. There are 11 selections from 10us (100ksps) to 100ms.

◆ Measurement setup

These settings are already set in the “Analog wave monitor” function. Tap “Edit” to change.

* Analog wave monitor function and analog measurement (logger) function can work simultaneously.

2.8 Preparation of analog signal measurement for multi channels

It is possible to measure max 8ch of analog value by using the analog measurement pod. Only the analog measurement (logger) function is available for multi channels.

 Chapter 4 Analog measurement function

■ Expansion pod

- Use OP-8AH when measuring max $\pm 60V$ analog signals.

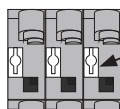
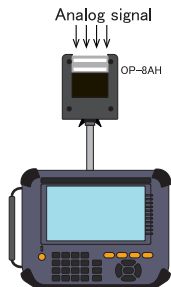

Use the minus screw driver when connecting/removing the cables

- Use OP-8AT (option) when measuring the temperature, or measuring the analog signals with different electrical potential on the ground.

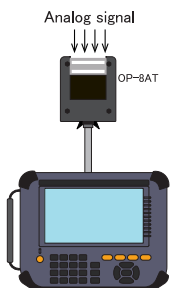

Measuring temperature
Use a thermocouple.

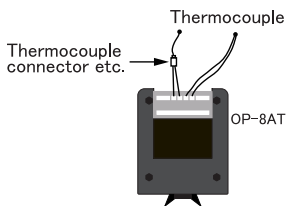

■ Connection

Connect the analyzer and the expansion pod using the POD connection cable. Connect the analog inputs to the expansion pod.

■ Example of pin assignment for OP-8AH

| Screw-less terminal 10x2lines | |
|-------------------------------|----------------------------|
| Symbol | Description |
| 1 | Analog input channel 1 |
| 2 | Analog input channel 2 |
| 3 | Analog input channel 3 |
| 4 | Analog input channel 4 |
| 5 | Analog input channel 5 |
| 6 | Analog input channel 6 |
| 7 | Analog input channel 7 |
| 8 | Analog input channel 8 |
| IN | External trigger input *1 |
| OUT | External trigger output *1 |
| GND | Signal ground *2 |

*1: Use for external trigger function.



2.9 Preparation of measuring the external trigger

*2: Inputs are not isolated. GND is for all inputs.

■ Setting of expansion pod “OP-8AH”

Tap “Analog Config” for each mode and go to the analog input option screen. Select “OP-8AH” in “Analog Measurement”.

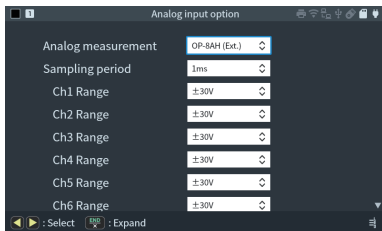

◆ Sampling period

Select the sampling period. There are 8 selections from 62.5us (16Ksps) to 100ms .

◆ Chx Range

Select the input range of each analog input terminal. There are 5 selection from $\pm 4V \sim \pm 60V$.

■ Connection of expansion pod “OP-8AT”

| Screw-less terminal 10x2lines | |
|-------------------------------|---|
| Symbol | Description |
| 1+ | Analog input channel 1 |
| 1- | Analog input channel 1 ground |
| 2+ | Analog input channel 2 |
| 2- | Analog input channel 2 ground |
| 3+ | Analog input channel 3 |
| 3- | Analog input channel 3 ground |
| 4+ | Analog input channel 4 |
| 4- | Analog input channel 4 ground |
| 5+ | Analog input channel 5 |
| 5- | Analog input channel 5 ground |
| 6+ | Analog input channel 6 |
| 6- | Analog input channel 6 ground |
| 7+ | Analog input channel 7 |
| 7- | Analog input channel 7 ground |
| 8+ | Analog input channel 8 |
| 8- | Analog input channel 8 ground |
| IN | External trigger input ^{*1} |
| OUT | External trigger output ^{*1} |
| GND | External trigger input/ outputground |

[Input Circuit]

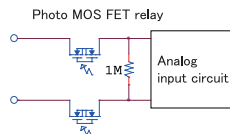

*1 Use for external trigger function.



2.9 Preparation of measuring the external trigger

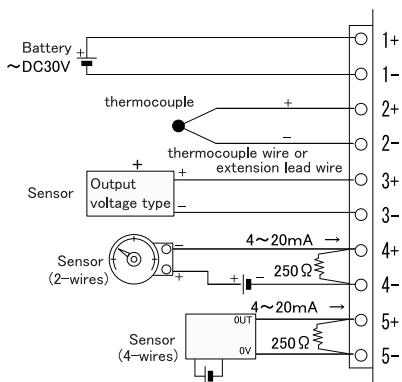

* Input channel 6/7/8 are also available.

■ Setting of expansion pod “OP-8AT”

Tap “Analog Config” for each mode and go to the analog input option screen.

Select “OP-8AT” in “Analog Measurement”.

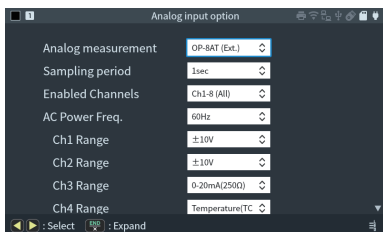

◆ Sampling period

Select the sampling period. There are 12 selections from 10ms to 1 minute.

◆ Enabled Channels

Select the number of enable channels.

* It takes about 5ms to change the isolated channel. Therefore, enable channel is 1 for 10ms cycle and 3 for 20ms cycle.

◆ AC Power Freq.

Select 60Hz or 50Hz. (60Hz for western Japan and 50Hz for eastern Japan)

It will minimize the effects from power noise

Appropriate sampling time will be set automatically according to the “Sampling period”, “Enabled channels” and “AC Power Freq.”. When measuring 8 channels, the most accurate sampling cycle is 1s (or more).

◆ Ch x Range

Select the input range of analog input terminal.

$\pm 100\text{mV}$, $\pm 1\text{V}$, $\pm 10\text{V}$, $\pm 30\text{V}$: It measures the voltage within the selected range.

$0\text{-}20\text{mA}(250\Omega)$, $0\text{-}20\text{mA}(50\Omega)$: It measures the current using the optional 250Ω resistor (LA-S10250RB).

Temperature : It measures the temperature using the thermocouples.

◆ TC type, Burnout detection, CJ compensation

When selecting “temperature” for Ch range, above selections are appeared.

TC type : Select the thermocouples type from K, J, T, E, N, R, S, B.

Burnout detection : Mark on the box to detect the burnout. Disable this function if the thermocouples are very long and the voltage for detecting burnout may cause the malfunction.

Cold junction compensation : Mark on the box for normal use. Disable this function if using the external compensation device or ice both.

2.9 Preparation of measuring the external trigger

To measure the external triggers, use the trigger in/out on the external trigger/expansion analog port, or trigger terminal on the expansion analog pods (OP-8AH/OP-8AT).

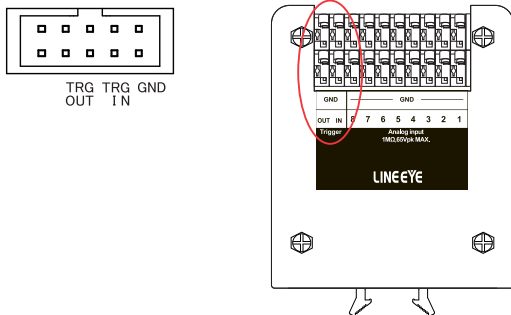

| Signal | In/Out | Signal level/Description |
|---------|--------|------------------------------------|
| TRG IN | Input | TTL level (Input range:-0.5V ~ 6V) |
| TRG OUT | Output | Open collector 5V (10kΩ pull-up) |
| GND | - | Signal ground |

2.10 Preparation of GPS signal measurement and GPS/PPS synchronous

It is possible to measure the positioning information by connecting the optional GPS active antenna on the GPS port. In addition, it is possible to synchronize the time stamp by the PPS signals acquired by other LE-8500X/ LE-8600X series.

■ GPS active antenna

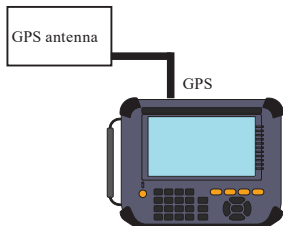

It measures the positioning information and synchronizes the time stamp with GPS.

■ External PPS signal

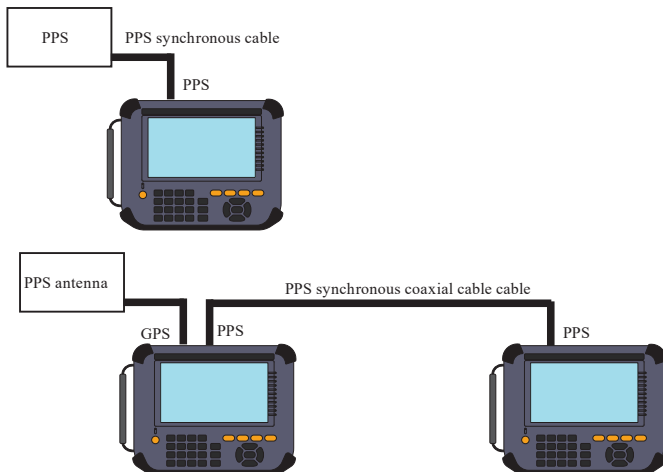

It can synchronize the time stamp acquired by other LE-8500X/ LE-8600X series.

■ Setting

Go to “Record control” -> “Additional info.” From top menu.

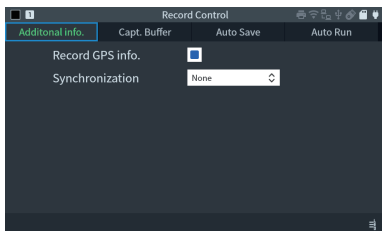

◆ Record GPS info.

It records the positioning information acquired by the GPS active antenna.

◆ Synchronization

It synchronizes the time stamp information acquired by the GPS antenna or external PPS devices. Please refer to the instruction manual of LE-8500X/ LE-8600X series and read about “Synchronization of time stamp”.

Chapter 3 Online Monitor Function

3.1 Outline





Online monitor function displays/records CAN/CAN FD frames, received time (time stamp), analog signals, GPS signals and status of external trigger signals in real time without affecting any communication lines.

Moreover, specifying the trigger conditions and actions allows effective analysis.

It is possible to scroll recorded data and search specific data in the capture buffer.

3.2 Start measuring

Before starting the measurement, set the measurement conditions.

-  2.6 Preparation of CAN/CAN FD measurement
-  2.7 Preparation of High-speed analog measurement
-  2.8 Preparation of analog signal measurement for multi channels
-  2.9 Preparation of measuring the external trigger
-  2.10 Preparation of GPS signal measurement and
GPS/PPS synchronous

Press [RUN] to start measuring. “●” is displayed on the left top during the measurement.



| Time | Ch | ID | TYPE | DL | ST | Data | FC |
|---------------|----|----------|--------|----|----|---|----------|
| 21:07.6582335 | 1 | 00F00501 | DATA | 8 | OK | 7E 80 00 7D 00 00 00 00 | 1E FA |
| 21:08.462224 | 1 | 18FEFFFF | DATA | 8 | OK | 40 33 33 33 33 33 33 33 | 1A C7 |
| 21:08.861510 | 1 | 00800001 | REMOTE | 2 | OK | | 3E 85 |
| 21:20.001375 | 2 | 050 | DATA | 8 | OK | 01 82 83 84 85 86 87 88 | 58 45 |
| 21:20.701543 | 2 | 051 | DATA | 8 | OK | 88 87 86 85 84 83 82 81 | 08 4E |
| 21:35.701073 | 1 | 00F00501 | DATA | 8 | OK | 7E 80 00 7D 00 00 00 00 | 1E FA |
| 21:45.664012 | 1 | 1E1 | DATA | 64 | OK | 20 31 32 33 34 35 36 37 80AA 75 | |
| 21:46.609942 | 1 | 001EE100 | FDATA* | 64 | OK | 41 48 4A 4B 4C 4D 4E 4F 50 51 52 53 54 55 56 57 58 59 5A 5B 5C 5D 5E 5F | 12 D1 C1 |
| 22:05.149330 | 2 | 050 | DATA | 8 | OK | 01 82 83 84 85 86 87 88 | 58 45 |
| 20:59.352515 | 1 | 00F00501 | DATA | 8 | OK | 7E 80 00 7D 00 00 00 00 | 1E FA |
| 20:59.812414 | 1 | 18FEFFFF | DATA | 8 | OK | 40 33 33 33 33 33 33 33 | 1A C7 |
| 21:00.171718 | 1 | 020 | REMOTE | 0 | OK | | 45 42 |
| 21:00.611883 | 1 | 00800001 | REMOTE | 2 | OK | | 3E 85 |
| 21:00.952371 | 1 | 1CFEB302 | DATA | 8 | OK | 04 55 AA 00 91 00 00 07 | 58 13 |

It displays data in real time and captures data in the capture buffer.

■ Pause displaying data

Press [ESC] or touch “Pause Display”, then the motion on the screen temporarily seems to be stopped while measurement is still continuing. The color of “Pause Display” will be changed while pausing the measurement. Press “Pause Display” or [ESC] key again to display the data in real time.

3.3 End of measurement

Press [STOP] to stop monitoring and “■” is displayed in the upper left of screen.







Also, it stops monitoring when the trigger condition is satisfied or capturing buffer becomes full.

 Chapter 7 Trigger Function

Refer to the instruction manual of LE-8600X/ LE-8500X series for full-stop function of capture buffer. Read “Basic operation”, “Record control”, “Capture buffer” and “Record control” in the manual.

3.4 Change displays

Online monitor function has following displays.

| | | |
|---|-----------------------|---|
| 1 | Frame display | Displays CAN/CAN FD frames  3.4.1 Frame display |
| 2 | Analog display | Displays analog value of Analog measurement (logger) function.  4.2 Analog display |
| 3 | GPS data display | Displays GPS (GNSS) positioning information.  3.4.2 GPS data display |
| 4 | Analog wave display | Displays data of Analog wave monitor function  5.4 Analog waveform display screen |
| 5 | Digital wave display | Displays data of Digital wave monitor function.  5.5 Digital waveform display screen |
| 6 | Timer/counter display | Displays timer/counter value and numbers of CAN/CAN frames.  3.4.3 Timer/ Counter display |

Tap “Change display” on the screen to change the display mode.

* Some of the display modes may not be displayed because of its settings.

When tapping the “Change display” after scrolling data of Frame, Analog, or GPS data displays, it displays data with nearest time stamp started from the last displayed data.

3.4.1 Frame display

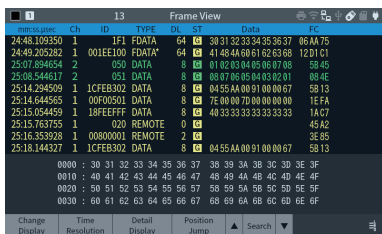

It displays CAN/ CAN FD frames in the time order. Channel 1 is in yellow, and Channel 2 is in green. It is possible to scroll data by [▲] [▼] keys or swipe data after the measurement. When CAN FD reaches to 8byte data on the top of the main screen, data field window will be displayed on the bottom of the screen.

* Data field window is not available while scrolling data or using the two-divided screen.

Following is the descriptions of data.

| | | |
|------------|--|-----------------------------------|
| mm:ss.µsec | Display time stamp. | |
| Ch | Display received channel. | |
| ID | Display ID of received frame | |
| TYPE | Display a type of received frame. | |
| | DATA | CAN Data frame |
| | REMOTE | Remote frame |
| | FDATA | CAN FDData frame |
| | FDATA* | CAN FD data frame when BRS=1 |
| | FDATA! | CAN FD data frame of ESI=1 |
| | FDATA*! | CAN FD data frame of BRS=1, ESI=1 |
| | ERROR | Error frame |
| DL | Display data length code in decimal. | |
| ST | Display normal or abnormal of a frame. | |
| | G | Normal frame |
| | A | NAK (ACK error) |
| | F | Form error |
| | C | CRC error |
| | E | Error frame |
| Data | Data field value (in HEX) | |
| FC | It displays CRC in HEX. | |

■ Change the time stamp display

Tap “Time Resolution” to change the display of time stamp

| | |
|----------------|---|
| mm:ss.µsec | Minute, Second, Micro-second. |
| hh:mm:ss.msec | Hour, Minute, Second, Micro-second. |
| MM/DD hh:mm:ss | Month/Day, Hour, Minute, Second |
| YY/MM/DD hh:mm | Year/Month/Day, Hour, Minute |
| Δ time | Elapsed time from the last frame (second) |

Press [SHIFT]+ “Relative Timestamp” to count the time stamp starting from the measurement. (Starting time becomes the time stamp “0”.) Press the same key to cancel this operation.

While “Relative Timestamp” is running, time stamp display are changed in following order by tapping “Change display”.

| | |
|---------------|---|
| Elapsed(sec.) | Second (6digits after the decimal point) |
| Elapsed(sec.) | Second (3digits after the decimal point) |
| Days hh:mm:ss | Day, Hour, Minute, Second |
| Δ time | Elapsed time from the last frame (second) |

(“Δ time” is same in normal timestamp and relative time stamp.)

■ Detail display (translation)

Tap “Detail Display” after stopping the measurement to open the details (translated) of frames on the bottom of screen. Tap “Detail Display” again to close it.

 Chapter 8 Translation function

3.4.2 GPS data display

| TimeStamp | UTC | Q | N | Latitude | Longitude | Err.[m] | Altitude |
|--------------|----------|---|----|---------------|----------------|---------|----------|
| 06:16.065247 | 01:06:16 | 8 | 28 | N 34 58.82121 | E 135 43.89157 | 0.68 | 25.55 |
| 06:17.055254 | 01:06:17 | 8 | 28 | N 34 58.82113 | E 135 43.89156 | 0.67 | 25.39 |
| 06:18.055248 | 01:06:18 | 8 | 28 | N 34 58.82105 | E 135 43.89155 | 0.66 | 25.39 |
| 06:19.055242 | 01:06:19 | 7 | 27 | N 34 58.82099 | E 135 43.89151 | 0.66 | 25.41 |
| 06:20.055238 | 01:06:20 | 8 | 29 | N 34 58.82097 | E 135 43.89146 | 0.66 | 25.33 |
| 06:21.065220 | 01:06:21 | 8 | 29 | N 34 58.82094 | E 135 43.89142 | 0.66 | 25.31 |
| 06:22.065212 | 01:06:22 | 8 | 29 | N 34 58.82092 | E 135 43.89142 | 0.66 | 25.38 |
| 06:23.055214 | 01:06:23 | 8 | 28 | N 34 58.82093 | E 135 43.89140 | 0.65 | 25.38 |
| 06:24.055207 | 01:06:24 | 8 | 29 | N 34 58.82094 | E 135 43.89140 | 0.66 | 25.34 |
| 06:25.055201 | 01:06:25 | 8 | 29 | N 34 58.82095 | E 135 43.89140 | 0.66 | 25.30 |
| 06:26.055199 | 01:06:26 | 8 | 29 | N 34 58.82095 | E 135 43.89142 | 0.66 | 25.61 |
| 06:27.055189 | 01:06:27 | 8 | 29 | N 34 58.82096 | E 135 43.89145 | 0.67 | 25.87 |
| 06:28.055188 | 01:06:28 | 8 | 29 | N 34 58.82097 | E 135 43.89148 | 0.67 | 26.10 |
| 06:29.055168 | 01:06:29 | 8 | 28 | N 34 58.82097 | E 135 43.89149 | 0.67 | 26.25 |
| 06:30.055176 | 01:06:30 | 8 | 28 | N 34 58.82096 | E 135 43.89148 | 0.68 | 26.31 |

It records GPS positioning data. Go to “Record control” -> [Additional info.] and mark on the box of “Record GPS info.”



2.10 Preparation of GPS signal measurement and GPS/PPS synchronous

It is possible to use it in the split display.

Following is the descriptions.

| | |
|---------------------------|--|
| mm:ss.μ sec ^{*1} | Display time stamp. ^{*2} |
| UTC | UTC time acquired by the GPS module |
| Q | Quality |
| | I No measurement |
| | T UTC time only |
| | G GPS (GNSS) available |
| | S GPS (GNSS) available (Correction from the QZSS SLAS/SBAS) |
| N | Numbers of satellite used |
| Latitude | Latitude |
| Longitude | Longitude |
| Err.[m] | 2D Positioning Estimation Accuracy |
| Alt.[m] | Sea level attitude |

*1 Same as the Frame display. Refer to the description of Frame display.

*2 RTC value of analyzer. There are some interval because of the processing time and communication time of analyzer, even using the GPS synchronous function.

3.4.3 Timer/ Counter display

It displays the setting value and current value of Timer0-Timer3/ Counter0-Counter3. Also, it displays the number of frames on Ch1 and Ch2 of CAN/ CAN FD port.

| Timer | Set | Now | Unit |
|-------|-----|-----|-------|
| 0 | 1 | 0 | x10ms |
| 1 | 1 | 0 | x10ms |
| 2 | 1 | 0 | x10ms |
| 3 | 1 | 0 | x10ms |

| Counter | Set | Now |
|----------|-----|-----|
| 0 | 1 | 0 |
| 1 | 1 | 0 |
| 2 | 1 | 0 |
| 3 | 1 | 0 |
| CAN CH 1 | | 49 |
| CAN CH 2 | | 49 |

7.4 Timer/Counter function

3.5 Jump function

You can quickly view the desired data on the Frame display, Analog display (numeric display), and GPS data display screens.

■ Potion Jump

Tap “Jump” to display the data for the entered position at the top of the screen.

| Time (ms) | Ch | ID | TYPE | DL | ST | Data | FC |
|--------------|----|-----|--------|----|----|-------------------------|---------|
| 28:40:471267 | 2 | 555 | FDATA* | 64 | 08 | 55 56 57 58 59 5A 5B 5C | 04FE 9C |
| 28:40:471267 | 1 | 555 | FDATA* | 64 | 08 | 55 56 57 58 59 5A 5B 5C | 04FE 9C |
| 28:50:927318 | 2 | 555 | FDATA* | 64 | 08 | 55 56 57 58 59 5A 5B 5C | 04FE 9C |
| 28:50:927318 | 1 | | | | | | E 9C |
| 28:51:295400 | 2 | | | | | | 3FF |
| 28:51:295400 | 1 | | | | | | 3FF |
| 28:56:863063 | 2 | | | | | | 3AA |
| 28:56:863063 | 1 | | | | | | 8AA |
| 28:57:571620 | 2 | | | | | | 3FF |
| 28:57:571620 | 1 | | | | | | 3FF |

■ Mark Jump

Register data and then display it on the top of screen by pressing the number key. Marks (M1 to M9) can be added to up to 9 locations.

| Time (ms) | Ch | ID | TYPE | DL | ST | Data | FC | Mark |
|--------------|----|----------|--------|----|----|-------------------------|-------|------|
| 28:51:295400 | 2 | 15555555 | DATA | 8 | 08 | 55 AA 00 FF 0F F0 80 00 | 73FF | M1 |
| 28:51:295400 | 1 | 15555555 | DATA | 8 | 08 | 55 AA 00 FF 0F F0 80 00 | 73FF | |
| 28:56:863063 | 2 | 1FFFFFFF | REMOTE | 8 | 08 | | 18 4A | M2 |
| 28:56:863063 | 1 | 1FFFFFFF | REMOTE | 8 | 08 | | 18 4A | |
| 28:57:571620 | 2 | 15555555 | DATA | 8 | 08 | 55 AA 00 FF 0F F0 80 00 | 73FF | |
| 28:57:571620 | 1 | 15555555 | DATA | 8 | 08 | 55 AA 00 FF 0F F0 80 00 | 73FF | |
| 28:59:830116 | 2 | 7FF | REMOTE | 8 | 08 | | 20 ED | |
| 28:59:830116 | 1 | 7FF | REMOTE | 8 | 08 | | 20 ED | |
| 29:01:042221 | 2 | 7FF | REMOTE | 8 | 08 | | 20 ED | |
| 29:01:042221 | 1 | 7FF | REMOTE | 8 | 08 | | 20 ED | |
| 29:04:369848 | 2 | 15555555 | DATA | 8 | 08 | 55 AA 00 FF 0F F0 80 00 | 73FF | |
| 29:04:369848 | 1 | 15555555 | DATA | 8 | 08 | 55 AA 00 FF 0F F0 80 00 | 73FF | |
| 29:05:303281 | 2 | 15555555 | DATA | 8 | 08 | 55 AA 00 FF 0F F0 80 00 | 73FF | |
| 29:05:303281 | 1 | 15555555 | DATA | 8 | 08 | 55 AA 00 FF 0F F0 80 00 | 73FF | |
| 29:05:943303 | 2 | 15555555 | DATA | 8 | 08 | 55 AA 00 FF 0F F0 80 00 | 73FF | |
| 29:05:943303 | 1 | 15555555 | DATA | 8 | 08 | 55 AA 00 FF 0F F0 80 00 | 73FF | |

Operation is following

[SHIFT] + [1]-[9] : The key number mark (M1 to M9) is set to the data displayed at the top of the screen. To delete, press the same numbered key again.

[1]-[9] : Jump to the key number mark (displayed at the top of the screen).

[SHIFT]+ “Mark Jump” : Displays the “Mark Position” screen (list of settings for Marker 1 to 9).

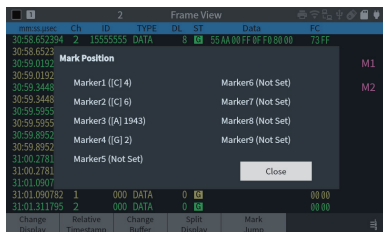

Descriptions of each symbols.

[C] Number : Frame number marked on the “CAN/CAN FD frame display” screen.

[A] Number : Data number marked on the “analog display” screen.

[G] Number : Data number marked on the “GPS display” screen.

You can also tap a marker on the “Mark Position” screen to jump to it.

3.6 Search function

Tap “Search” to find the specific data in the CAN/ CAN Frame display.

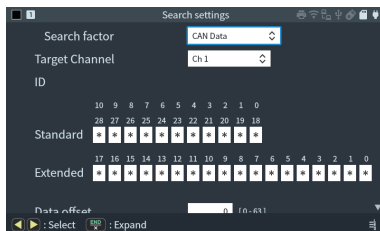

■ Search factor

◆ Trigger

Retrieve matched data with trigger factor.

It cannot search data if the search factor is “timer/ counter”.

◆ Error

Various error.

Select Ch1 or Ch2. It is able to search data on both channels.

◆ CAN data

Retrieve specific CAN/CAN FD frame

Select target channel, ID, data, Data offset. It is possible to set the “don’t care (*)” for ID, and bitmask and “don’t care (*)” for data.

◆ CAN remote

Retrieve specific CAN remote frame.

Select target channel and ID. It is possible to set the “don’t care (*)” for ID.

◆ Time stamp

Retrieve data of specified time.

■ Action

After setting the search factor, select the action.

◆ Count

It counts the numbers of matched data.

◆ “▲” or “▼”

It displays the matched data. “▲” means searching forward direction and “▼” means searching backward direction.

Tap “▲” or “▼” keys again to display next matched data.

3.7 Split display (display two separated screen)

It is possible to display data on BUF1 and BUF2 at the same time for Frame/ Analog/ GPS displays. It is useful to analyze and compare two different data.

| Frame View | | | | | | | |
|--------------|----|----------|--------|----|----|-------------------------|-------|
| mm:ss.uscc | Ch | ID | TYPE | DL | ST | Data | FC |
| 35:25.846076 | 2 | 555 | DATA | 8 | 00 | 55 AA 00 FF 0F F0 B0 01 | 62 7E |
| 35:25.846076 | 1 | 555 | DATA | 8 | 00 | 55 AA 00 FF 0F F0 B0 01 | 62 7E |
| 35:26.237468 | 2 | 15555555 | DATA | 8 | 00 | 55 AA 00 FF 0F F0 B0 00 | 73 FF |
| 35:26.237462 | 1 | 15555555 | DATA | 8 | 00 | 55 AA 00 FF 0F F0 B0 00 | 73 FF |
| 35:26.627152 | 2 | 7FF | REMOTE | 8 | 00 | | 20 ED |
| 35:26.627152 | 1 | 7FF | REMOTE | 8 | 00 | | 20 ED |

| 4 | | | | | | | |
|--------------|----|----------|--------|----|----|----------------------------------|-------|
| mm:ss.uscc | Ch | ID | TYPE | DL | ST | Data | FC |
| 35:48.087354 | 2 | 7FF | REMOTE | 8 | 00 | | 20 ED |
| 35:48.087354 | 1 | 7FF | REMOTE | 8 | 00 | | 20 ED |
| 35:48.619420 | 2 | 555 | FDATA* | 64 | 00 | 55 56 57 58 59 5A 5B 5C 0A FE 9C | |
| 35:48.619420 | 1 | 555 | FDATA* | 64 | 00 | 55 56 57 58 59 5A 5B 5C 0A FE 9C | |
| 35:48.884120 | 2 | 15555555 | FDATA | 64 | 00 | AA AB AC AD AE AF B0 B1 10 02 8C | |
| 35:48.884120 | 1 | 15555555 | FDATA | 64 | 00 | AA AB AC AD AE AF B0 B1 10 02 8C | |

- 1) Save data in BUF1. Select BUF1 from “Record control” and measure/ load data.
- 2) Press [SHIFT] + “Change Buffer” and measure/ load data on BUF2.
- 3) Press [SHIFT] + “Split display” to display split data of BUF1 and BUF2.
- 4) Press [SHIFT] + “Unite display” to cancel the split data.

During displaying the split data, “data field window” will not be appeared.

To scroll the two-divided data at the same time, tap “SYNC”. The color of “SYNC” will be changed.

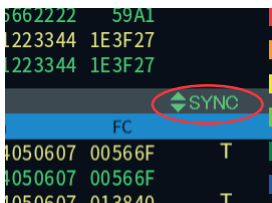

Press [▲] or [▼] keys to scroll the data synchronously. Tap “SYNC” again to invalid the function.

Chapter 4 Analog measurement function

4.1 Outline

It records input value on the selected analog port along with the time stamp. Select the target from analog measurement pod (max 8ch), analog input (BNC connector) port, or signal voltage of CAN Ch1.

 2.7 Preparation of High-speed analog measurement

 2.8 Preparation of analog signal measurement for multi channels

For online manual mode, it is possible to record analog value and CAN/CAN FD data at the same time.

 2.5 Measurement mode.

Operation (start/end of measurement) is same as the online monitor function

 Chapter 3 Online Monitor Function

If using the attached passive probe and use the analyzer as an oscilloscope, refer to the chapter 5 (analog wave monitor function).

4.2 Analog display

4.2.1 Analog value display

It displays the analog value (voltage) of each channels at the sampling cycle. It is possible to scroll data by[▲] [▼] keys or swipe data after the measurement. Split data display is available.



| mm:ss.μsec | AI1V | AI2V | AI3V | AI4V | AI5V | AI6V | AI7V | AI8V |
|--------------|---------|---------|---------|---------|---------|---------|---------|---------|
| 41:12.352365 | +86.621 | +85.199 | -05.799 | +12.243 | +1.9910 | +0.000 | +0.0006 | +00.001 |
| 41:12.353365 | +86.621 | +85.198 | -05.799 | +12.243 | +1.9409 | +0.000 | +0.0004 | +00.001 |
| 41:12.354365 | +86.621 | +85.198 | -05.799 | +12.243 | +1.9408 | -00.000 | +0.0004 | +00.001 |
| 41:12.355364 | +86.621 | +85.198 | -05.798 | +12.243 | +1.6992 | +0.000 | +0.0002 | +00.000 |
| 41:12.356364 | +86.621 | +85.198 | -05.799 | +12.243 | +1.5141 | -00.001 | +0.0001 | +00.001 |
| 41:12.357364 | +86.621 | +85.198 | -05.799 | +12.243 | +1.2917 | -00.001 | +0.0001 | -00.000 |
| 41:12.358364 | +86.621 | +85.198 | -05.798 | +12.243 | +1.0372 | -00.001 | -0.0000 | +00.000 |
| 41:12.359364 | +86.622 | +85.198 | -05.799 | +12.243 | +0.7979 | -00.001 | +0.0001 | -00.000 |
| 41:12.360364 | +86.621 | +85.199 | -05.799 | +12.243 | +0.4592 | -00.001 | -0.0002 | -00.000 |
| 41:12.361364 | +86.621 | +85.198 | -05.799 | +12.243 | +0.1497 | -00.001 | -0.0002 | -00.000 |
| 41:12.362364 | +86.621 | +85.199 | -05.798 | +12.243 | -0.1655 | -00.001 | -0.0001 | +00.000 |
| 41:12.363364 | +86.621 | +85.198 | -05.798 | +12.243 | -0.4728 | -00.001 | +0.0000 | +00.000 |
| 41:12.364364 | +86.621 | +85.198 | -05.799 | +12.243 | -0.7783 | +00.000 | +0.0002 | +00.001 |
| 41:12.365364 | +86.621 | +85.198 | -05.799 | +12.243 | -1.0488 | -00.000 | +0.0003 | +00.000 |
| 41:12.366364 | +86.622 | +85.198 | -05.798 | +12.243 | -1.3018 | -00.000 | +0.0005 | +00.001 |

| | |
|--------------------------|--|
| mm:ss.μsec ^{*1} | Display time stamp. |
| AI 1 ~ 8 ^{*2*3} | Analog value of each channels. Unit (V/ mV etc) is displayed on the label section. |

- * 1 : It is same at the Frame display.
- * 2 : If selecting “On-board”, only AI1 to AI2 are displayed. For OP-8AT, only valid inputs are displayed.
- * 3 : If selecting “On-board” and measuring voltage of CAN signals, AI1 is for CAN1 High and AI2 is for CAN1 Low.

4.2.2 Analog graph display

Tap “Change Display” at Analog value display to change to Analog graph display.

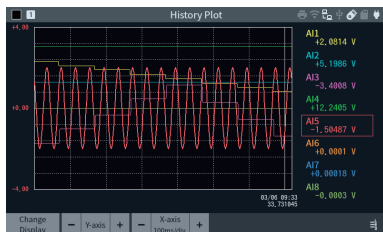

It shows the changes of analog inputs with time lapse of time. Y-axis is for analog value (voltage, temperature) and X-axis is for time. It is able to scroll data by [◀] [▶] keys, or swipe data after the measurement. Appointed data by the cursor is displayed on the right side of screen. Change the appointed data by [▲] [▼] keys on the right side of screen or tap the target data. Appointed data is displayed in bold strokes and appeared in the front row.

Tap +/- of Y-axis to increase/decrease the Y-axis. Press [SHIFT] + [▲] [▼] keys to move the position of graph up and down.

Tap +/- of X-axis to increase/decrease the duration of time.

Press [1] ~ [8] keys not to display the selected channel. Press the same number key to display the target channel again.

If selecting “graph” for translation function, translated CAN data are displayed in graph instead of analog value (AI1 to AI8).

 Chapter 8 Translation function

Chapter 5 Analog wave monitor function

5.1 Outline

There are 2 kinds of wave monitor functions in SB-C2AN.

■ Analog wave monitor function

It measures imputing voltage of Analog Input port (BNC connector). In addition, it measures the signal voltage of Ch1 (CAN/ CAN FD port) max at 100MHz sampling clock, operating as an oscilloscope.

■ Digital wave monitor (logic analyzer) function

It measure the digital waveform (logical status) of Ch1/ Ch2 (CAN/ CAN FD ports) max at 100MHz sampling clock.

5.2 Settings

■ Setting of analog wave monito

Refer to the manual (“Preparation of high-speed analog measurement”)

 2.7 Preparation of High-speed analog measurement

■ Digital wave monitor (logic analyzer)

It measure the digital waveform (logical status) of Ch1/ Ch2 (CAN/ CAN FD ports) max at 100MHz sampling clock.

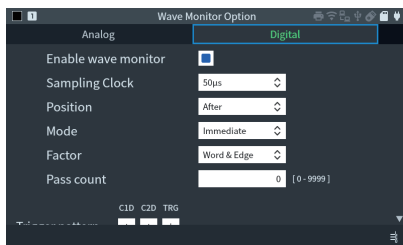

◆ Enable wave monitor

Mark on the box to measure the digital waveform monitor.

◆ Sampling Clock

Select the sampling clock of target communication. Select 5 to 10 times faster than the target device. For example, if the target device is 500Kbps, select the sampling clock from 500ns to 200ns.

◆ Position

Sets the trigger position in sampling memory.

Before : Set this when you want to capture more data before the trigger point.

Center : Set this when you want to capture an equal amount of data before and after the trigger point.

After : Set this when you want to capture more data after the trigger point.

◆ Mode

Immediate : Accepts the meeting of the trigger condition immediately after starting measurement.

Full : The trigger condition is accepted after capturing from the start of measurement to the maximum of the sampling memory.

If the trigger position is before or center, normally select “Full”.

◆ Factor

Select the trigger used for the waveform monitor function from “Word & Edge” and “Online”.

Word&Edge : Sets the CAN signal line status or rising/falling conditions as a trigger.

Online : Uses the trigger function of this unit.

◆ Trigger number

Select the trigger setting number to be used as the waveform monitor trigger when “Online” is selected for the trigger factor.

 Chapter 7 Trigger Function

◆ Pass count / Trigger pattern

When “Word & Edge” is selected as the trigger factor, a trigger occurs when each signal state or edge condition set in “Trigger Pattern” matches for the number of times set at “Pass count”.

5.3 Start

Press [RUN] to start measurement. “” will be displayed at the top of the screen until the waveform monitor trigger is met. Once the trigger is met, this display will disappear.

5.4 Analog waveform display screen





Displays the analog waveform of trigger timing as a graph.

The Y axis is voltage and the X axis is time.

The elapsed time relative to the trigger point is displayed at the top of the screen.

Swipe left or right or use [Shift]+[] [] keys to scroll the display.



Move the cursor (dashed blue line) using the [] and [] keys, and tap the 'mark' or press [Mark] to fix the current cursor position as a marker (dashed red line)



The cursor position, the measured value of the marker position, and the difference between them are displayed for A11 and A12 on the right side of the screen.

[C] : Voltage value at cursor position

[M] : Voltage value at marker position

[C-M] : Voltage difference between cursor and marker positions

You can scale the vertical axis of the target waveform from x1 to x50 by tapping the measured value area on the right side of the screen or by selecting A11 or A12 with the [] [] keys and then tapping +/- on the “Y axis”.

While zooming in, you can move the waveform display position up and down using the [SHIFT] + [] [] keys.

By tapping +/- on “X-axis”, you can enlarge or reduce the display time width on the horizontal axis from x4 to x1/64.

5.5 Digital waveform display screen

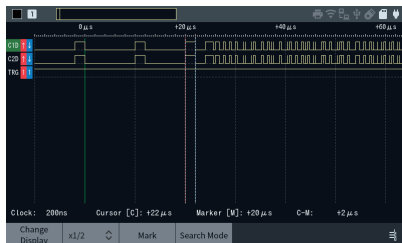

◆ Scrolling and scaling the display

Scroll to the part you want to see by pressing [SHIFT]+[◀] [▶] or swiping the screen left or right.

You can change the display magnification by tapping the magnification display displayed as “x1” at the bottom of the screen.

◆ Time between two points

Move the cursor with [◀] and [▶] and set a marker at the cursor position by pressing [ENTER] or tapping the “mark”.

“C-M:” displays the time between the cursor and marker.

◆ Search of signal status

When you touch “Search Mode” at the bottom of the screen, the status display (1, 0, ↓, ↑) at the cursor position on the left of the screen becomes x, and the area turns to be the input area of the signal status for the search target. Input here the state you want to search, and use [▲] and [▼] to search in that direction and move the cursor to the matching one. Touch “Search Mode” again to end the waveform search mode and [▲] and [▼] returns to cursor C movement.

◆ Change the display order of signal lines

Select the signal whose display order you want to change by [▲] and [▼]. Then you can use [SHIFT]+[▲] and [SHIFT]+[▼] to change the display order of the selected signals.

Chapter 6 Manual Simulation Function

6.1 Overview

When the target device is not available at the early stage of development, this device can act as a communication partner for the device under test and send CAN/CAN FD test frames.

6.2 Settings

Tap “Mode” “Manual” from the top menu and tap “Manual Opt.” to display the manual option screen.

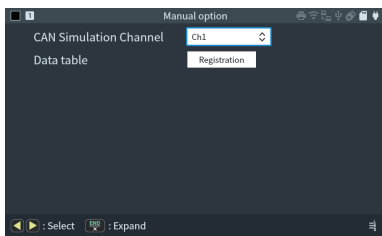

◆ CAN Simulation Ch

Register transmission CAN/CAN FD frames before starting simulation.

* Since the selected channel operates as a device, ACK will be automatically sent during measurement.

◆ Data table

Register the CAN/CAN FD frame to be transmitted in advance.

There are 16 main tables and 16 sub-tables for each main table, which can be sent using the device's keys (0 to F), and up to 272 types of test frames can be registered.

Tap “Register” to move to the CAN main table summary screen and register.

6.2.1 CAN main table summary screen

| No. | ID | Type | Data/DLC | Sub table |
|-----|----------|---------|-----------------------------|--------------------------------|
| 0 | 001 | DATA | 00 | Used Summary |
| 1 | 555 | DATA | 55 AA 00 FF 0F F0 80 01 | Unused Summary |
| 2 | 15555555 | DATA | 55 AA 00 FF 0F F0 80 00 | Unused Summary |
| 3 | 7FF | REMOTE | 8 | Unused Summary |
| 4 | 1FFFFFFF | REMOTE | 8 | Unused Summary |
| 5 | 555 | FD DATA | 55 56 57 58 59 5A 5B 5C ... | Unused Summary |
| 6 | 15555555 | FD DATA | AA AB AC AD AE AF B0 B1 ... | Unused Summary |
| 7 | 000 | DATA | | Unused Summary |
| 8 | 000 | DATA | | Unused Summary |

Displays 16 types of main tables from No.0 to F.

| | |
|-----------|--|
| No. | Main table number |
| ID | Displays the registered standard ID or extended ID in hexadecimal |
| Type | Displays the registered frame type Data : CAN data frame Remote : CAN remote frame FD data : CAN FD data frame |
| Data/DLC | If the registered frame type is a data frame, the first 8 bytes of data (hexadecimal) are displayed. Displays DLC value (decimal number) for remote frame |
| Sub table | If any of the 16 sub-tables is set to “valid”, it will be displayed as “used”, otherwise it will be displayed as “unused”. Tap “Summary” to move to the CAN sub-table summary screen. |

6.2.3 CAN subtable summary screen

When you tap the row of the table number to register, or select it using the 0 to F keys or [▲][▼] and press [ENTER], the transmission frame setting screen will be displayed.

| CAN Main Table 0 | |
|------------------|----------------------------------|
| Frame type | FD Data(Standard) ▾ |
| Standard ID | 123 [000 - 7FF] |
| Data | 00 01 02 03 04 05 06 07 ... Edit |
| Enable BRS | <input type="checkbox"/> |
| Repeat | 1 [0 - 9999] |
| Interval (ms) | 100 [1 - 9999] |
| Enable Sweep | <input type="checkbox"/> |

◆ Frame type

Select the frame type.

| | |
|-------------------|-------------------------------------|
| Data (standard) | CAN data frame (standard format) |
| Data(extended) | CAN data frame (extended format) |
| Remote(standard) | CAN remote frame (standard format) |
| Remote(extended) | CAN remote frame (extended format) |
| FD data(standard) | CAN FD data frame (standard format) |
| FD data(extended) | CAN FD data frame (extended format) |

◆ Standard ID /Extended ID

Enter the ID of the selected frame in hexadecimal.

◆ DLC

Displayed when “Remote” is selected for the frame type.

Select the data length from 0 to 8.

◆ Data

If the frame type is data (standard/extended) or FD data (standard/extended), enter the data in hexadecimal.

For FD data, tap “Edit” and enter on the “FD Data Edit” screen.



6.2.2 CAN FD data editing

◆ Enable BRS

In the case of FD data, if checked, BRS (Bit Rate Switch) will be set to recessive and the data will be sent at a higher transfer rate.

◆ Repeat

Set the number of times to repeat frame transmission. If set to “0”, it will continue to be sent repeatedly.

◆ Interval

Set the repeat transmission interval between 1 and 99999ms

◆ Enable Sweep

If checked, sweep operation will be performed. The setting screen for each parameter will be displayed.

◆ Size

Select the data size to be swept from 8 or 16 bits.

◆ Endian

When the data size to sweep is 16 bits, select the endian from little or big.

Select the endian from little or big

e.g) Set "0123h"

Little endian

| | |
|----|----|
| 23 | 01 |
|----|----|

 Big endian

| | |
|----|----|
| 01 | 23 |
|----|----|

◆ Position

Set the position of data field where sweep data is going to be inserted from

0 ~ 7 for CAN, 0 ~ 63 for CAN FD, 0 ~ 7 for LIN

e.g.) Size: 16bit, Position: 2

Two data in grey color is inserted. Other data are the one set on "Data" field



◆ Initial value, time/value 1-3

Set the initial value of the data to be swept and the value (target value) to be swept in the specified time (ms).

The relationship between target value and time is shown in the graph below.

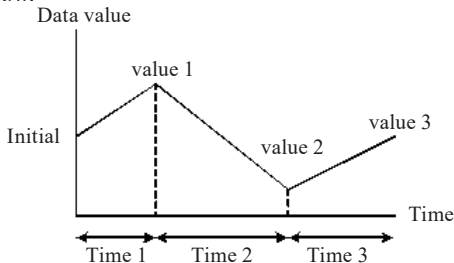

◆ Loop

If checked, it repeats the sweep.

6.2.2 CAN FD data editing

If you select “FD Data (Standard)” or “FD Data (Extended)” for the frame type, tap “Edit” to input data and enter the data in hexadecimal on the “FD Data Edit” screen.

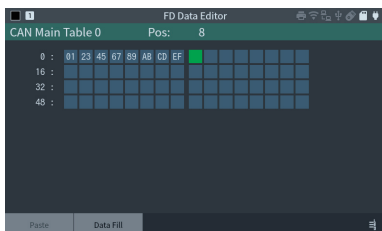

If the input data exceeds 8 bytes but is less than 12, 16, 20, 24, 32, 48, or 64 bytes, it will be padded with 00h.

Several editing functions are available to help you register data.

- Data Fill

Tap “Data Fill” on the data entry screen to display the data fill screen.

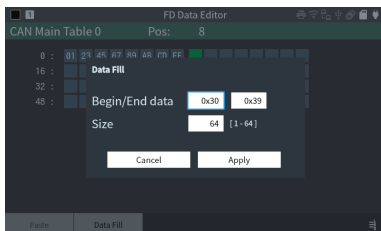

Inserts the data from “Begin data” to “End data” specified by “Size.”
(Example) If you execute with begin/end data “30” and “39” and size “64”, data from 30h to 39h will be repeatedly set in the table for 64 bytes.

- Selection mode

If you long-tap or press [ENTER] anywhere in the transmitted data, you will enter range selection mode with the data at that location selected.

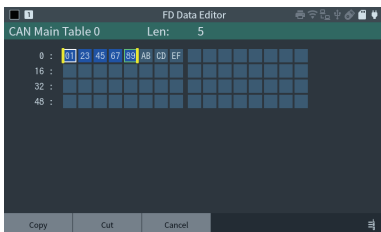

Specify the range by dragging the edge of the range or using the cursor keys, tap “Copy” or “Cut,” and then tap “Paste” to insert the data of the selected range at the cursor position.

6.2.3 CAN subtable summary screen

Tap “Summary” in the sub-table field on the CAN main table summary screen to move to the CAN sub-table summary screen for each main table.

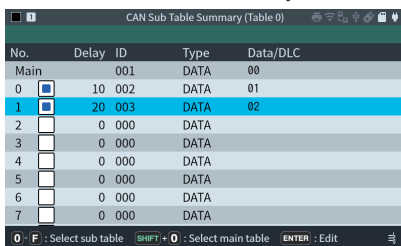

It displays a list of the selected main table and 16 types of sub-tables from No.0 to F.

| | |
|-------|--|
| No. | Subtable number The checkbox displays and changes the “enabled” status of the subtable. |
| Delay | Display the registered delay value |
| ID | Displays the registered standard ID or extended ID in hexadecimal |
| Type | Displays the registered frame type Data: CAN data frame Remote: CAN remote frame FD data: CAN FD data frame |

| | |
|---------------|---|
| Data / DLC | If the registered frame type is a data frame, the first 8 bytes of data (hexadecimal) are displayed. It displays DLC value (decimal number) for remote frame |
|---------------|---|

Tap the row of the table number to register or select it using the 0 to F keys or [▲][▼] and press [ENTER] to display the transmission frame registration screen.

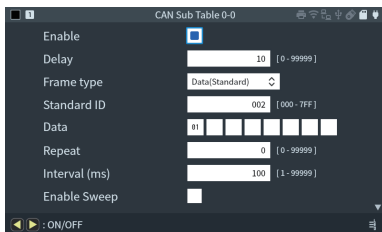

◆ Enable

Check this when using a subtable.

Main table frame sending operations automatically also send frames of enabled subtables.

◆ Delay

Set the first frame transmission delay time (msec).

This is the time from the start of the first frame transmission of the main table.

Other settings such as editing CAN FD data are the same as the main table, so please refer to the explanation of it.

 6.2.2 CAN FD data editing

- Example of usage of subtable

Send main table 0, subtable 0-0, subtable 0-1 periodically

| Settings | main table 0 | subtable 0-0 | subtable 0-1 |
|--------------|-----------------|-----------------|-----------------|
| Enable | — | Check | Check |
| Delay | — | 10 | 20 |
| Frame type | Data (Standard) | Data (Standard) | Data (Standard) |
| Standard ID | 001 | 002 | 003 |
| Data | 00 | 01 | 02 |
| Repeat | 0 | 0 | 0 |
| Interval | 100 | 100 | 100 |
| Enable Sweep | Unchecked | Unchecked | Unchecked |

(The main settings are as above, and subtables 0-2 to 0-F are not checked as “enabled”)

Transmission timing image

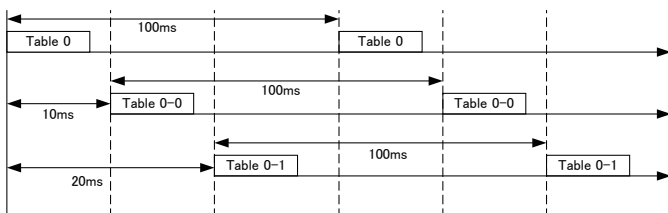

- Notes on manual simulation

During manual simulation, the simulation port of this machine always returns an ACK response to frames from other nodes.

When there is no ACK response from other nodes on the CAN bus or when a frame is sent, transmission may not always occur at the set time. Also, it may not be sent due to overlapping set times due to multiple table settings.

If the transmissions occur at the same time due to settings such as delay time, the table with the smaller table number will be sent preferentially.

6.3 Start

By pressing [RUN], you can send data while measuring the target communication line.

■ Data transmission

Press [0] to [F] to transmit the frame registered as transmission data. If subtable is enabled, subtable frames are also transmitted.

While repeating transmission, you can stop repeating by pressing [Shift] + [0] ~ [F]

* Data transmission operations cannot be performed on any screen other than the frame display screen.

6.4 End

Press [STOP] to stop the measurement operation.

Chapter 7 Trigger Function

7.1 Overview

The trigger function is a function that triggers a special measurement process (action) by a specific condition (factor) such as the occurrence of a communication error during measurement. By controlling the timer/counter, it can measure the communication response time and count the number of occurrences of specific events. This is useful when analyzing the flow of communication under the specific interest.

7.2 Settings

8 trigger factors and actions can be set.

Tap “Trigger” in the setting item for each mode to display the trigger summary screen.

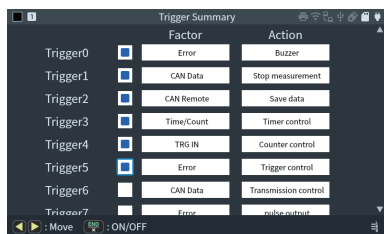

Check the checkbox for the trigger you want to enable at the start of measurement.

Trigger enable/disable can also be controlled by trigger operation during measurement.

Tap the setting display for each trigger factor and operation and configure settings on each setting screen.

If you want to use a timer/counter as a trigger, tap “Timer/Counter Settings” to set it in advance.

 7.4 Timer/Counter function

◆ Dara offset

Set the position from the beginning of the target data field.

The first position is 0.

◆ Data

Set the target data string (up to 8 bytes) in hexadecimal numbers from left to right.

* (don't care) and bitmask can also be specified.

Setting example: When targeting 09h of data field

| | | | | | | | | |
|-----|-----|-----|-----|-----|-----|-----|-----|-----|
| 01h | 02h | 03h | 04h | 05h | 06h | 07h | 08h | 09h |
|-----|-----|-----|-----|-----|-----|-----|-----|-----|

data offset 8

data 09

◆ Bit mask

You can specify a 1-byte bitmask (3 types: W0, W1, and W2) as the target data.

*(don't care) can also be specified.

When setting a bitmask, set W0, W1, and W2 in bits, and set W0 to W2 in "Data".

Setting Example

When the first byte is one of 01h, 11h, 21h, 31h, 41h, 51h, 61h, 71h, 81h, 91h, A1h, B1h, C1h, D1h, E1h, F1h, and the second byte is 42h.

Data W0 42

Bit mask

W0(bit7-0) * * * * 0 0 0 1

- CAN remote

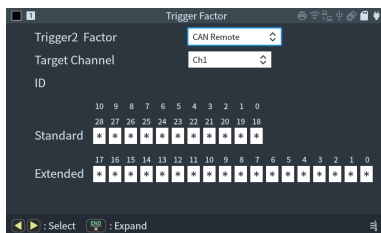

The condition is the occurrence of a specific remote frame set in the ID for the specified channel of CAN/CAN FD.
Please refer to the CAN data for details on how to set the target channel and ID standard field/extended field.

- Time/Count

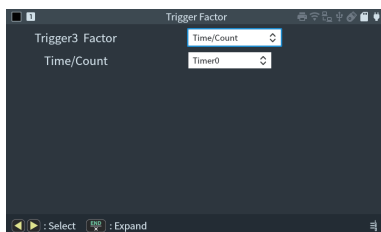

Select the target timer 0 to 3 or counter 0 to 3.
The condition is when timers 0 to 3 or counters 0 to 3 of this device reach the values set in advance on the timer/counter setting screen.

 7.4 Timer/Counter function

- TRG IN

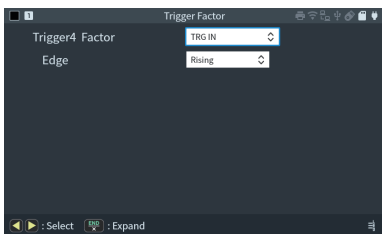

The condition is the state of the external trigger input signal (TRG IN).

Select from rising or falling external trigger signal.

 2.9 Preparation of measuring the external trigger

 A hold time of 100 μ S or more is required.

■ Trigger action

- Buzzer

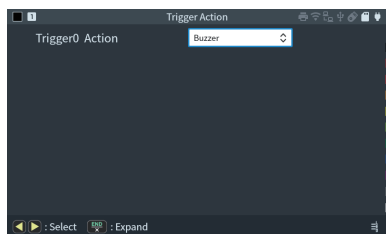

The buzzer sounds for about 0.3 seconds.

- Stop measurement

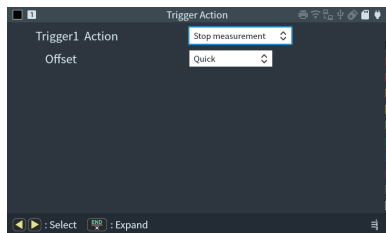

Measurement stops automatically.

◆ Offset

Set the conditions until the measurement stops after the trigger matches.

The measurement will automatically end after continuing measurement for the specified amount of time.

Quick : Immediately stops measurement

Before : Records more 64K data and then stops measurement

Center : Records half the capture buffer and then stops measurement

After : Stops the measurement keeping up to 64K data before trigger point

☰ “After” can record capture buffer size minus 64K data size after the trigger condition is met, so it can be used like a measurement start trigger.

* 1 data unit is 32 bytes. A CAN FD frame consumes up to 3 data.

• Save data

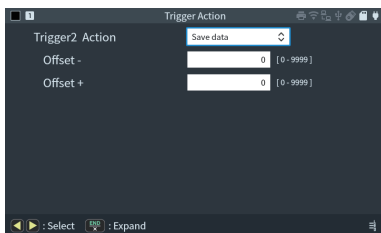

The measurement data before and after the trigger factor match is automatically saved in the storage device as a trigger save file (TGSAVEnn.DT - nn is a serial number from 0 to 99 in the order of saving). The amount to be saved at one time can be specified by the number of data (maximum 9999) before (offset-) / after (offset +) with the trigger point as the center.

Insert a storage device (SD card or USB flash drive) into this unit, and specify it at “Save Device” of the Auto save tab in “Record control” of [MENU].

☰ A CAN FD frame consumes up to 3 data units. If you want to be sure to include and save frames that matched with the trigger, set “Offset-” to 3 or more.

- 📄 After the trigger factor is matched, the offset + minute data is saved in the file when it is captured. If you stop the measurement before capturing the data of that size, the file will not be saved.
- 📄 The next data save operation is ignored during the data save process.
- 📄 After TGSAVE99.DT, it will be overwritten by returning to TGSAVE00.DT. When the measurement is started again, it will be overwritten from TGSAVE00.DT.
- 📄 It does not write if the storage device is full.

- Timer control

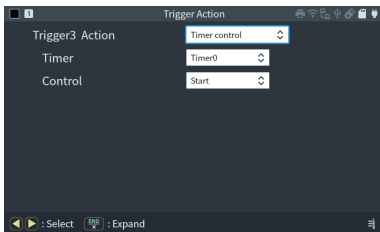

Starts or stops the specified timer or restarts it from 0.

- Counter control

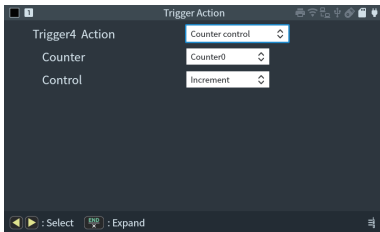

Adds 1 (increments) the specified counter or clears it to 0

- Trigger control

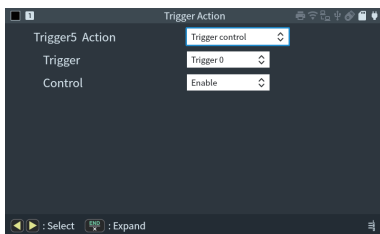

Enables, disables, or switches enable/disable (reverses the current enable/disable state) of the specified trigger factor.

A trigger that is invalid at the start of measurement can be enabled by another trigger when it detects a specific condition during the measurement (sequential trigger).

- Transmission control

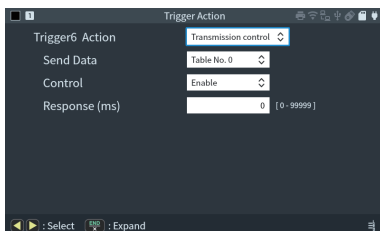

It controls CAN/CAN FD data table transmission.

Valid only during manual simulation.

- ◆ Send Data

Select the data table (main table) to control.

- ◆ Control

Select the control content (Enable: Send/Disable: Stop).

- ◆ Response(ms)

Enter the time until control starts.

 Chapter 6 Manual Simulation Function

 The next transmission process will be ignored until the transmission is complete.

- Pulse output

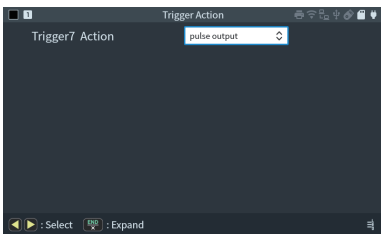

Output low pulse for about 1ms to external trigger output (TRG OT).

This device can detect the occurrence of special factors on the communication line and transmit the information to external measuring instruments such as an oscilloscope.

- 📄 When a new trigger is generated while the trigger pulse is being output, it goes to HIGH level
- 📄 about 1 ms after the last trigger is generated.

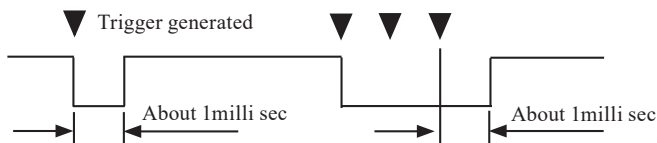

7.3 Display screen

When a trigger occurs, a “T” (trigger mark) will be displayed for each frame on the right side of the frame view screen (to the right of the FC column).

| Time | Ch | ID | TYPE | DL | ST | Data | FC |
|--------------|----|-----|--------|----|----|----------------------|----------|
| 01:20.732024 | 2 | 020 | REMOTE | 0 | | | 45A2 |
| 01:20.732976 | 1 | 131 | FDATA* | 64 | EE | E9 02 03 04 05 06 07 | 1788 0D |
| 01:20.732976 | 2 | 131 | FDATA* | 64 | EE | E9 02 03 04 05 06 07 | 1788 0D |
| 01:20.733974 | 1 | 131 | FDATA* | 64 | 2F | EA 02 03 04 05 06 07 | 1707 72 |
| 01:20.733974 | 2 | 131 | FDATA* | 64 | 2F | EA 02 03 04 05 06 07 | 1707 72 |
| 01:20.734973 | 1 | 131 | FDATA* | 64 | 71 | EA 02 03 04 05 06 07 | 07E5 56 |
| 01:20.734973 | 2 | 131 | FDATA* | 64 | 71 | EA 02 03 04 05 06 07 | 07E5 56 |
| 01:20.735975 | 1 | 131 | FDATA* | 64 | B2 | EA 02 03 04 05 06 07 | 1940 7F |
| 01:20.735975 | 2 | 131 | FDATA* | 64 | B2 | EA 02 03 04 05 06 07 | 1940 7F |
| 01:20.736975 | 1 | 131 | FDATA* | 64 | F4 | EA 02 03 04 05 06 07 | 131A 71 |
| 01:20.736975 | 2 | 131 | FDATA* | 64 | F4 | EA 02 03 04 05 06 07 | 131A 71 |
| 01:20.737974 | 1 | 131 | FDATA* | 64 | 36 | EB 02 03 04 05 06 07 | 0E 00 03 |
| 01:20.737974 | 2 | 131 | FDATA* | 64 | 36 | EB 02 03 04 05 06 07 | 0E 00 03 |
| 01:20.738974 | 1 | 131 | FDATA* | 64 | 77 | EB 02 03 04 05 06 07 | 1A44 88 |
| 01:20.738974 | 2 | 131 | FDATA* | 64 | 77 | EB 02 03 04 05 06 07 | 1A44 88 |

* TRG IN etc. are not synchronized with the captured frame, so no trigger mark will be attached.

7.4 Timer/Counter function

Timers 0 to 3 and counters 0 to 3 used in the trigger function, as well as a counter to count frames on channels 1 and 2 of the CAN/CANFD measurement port are available.

Please see the timer/counter display screen of the online monitor function.

 3.4.3 Timer/ Counter display

■ Timer/Counter action

- Timer action
 - 1) Cleared to 0 at the start of measurement. and the status changes to stop.
 - 2) It starts, stops, and restarts depending on the trigger action of the trigger function. When started or restarted, the current value of the timer will count up with the preset time resolution.
 - 3) The matching information between the timer comparison setting value and the timer current value is used as a trigger factor for timer matching.
 - 4) If the current value overflows, it continues counting from 0.
 - 5) When you stop the measurement, the timer also stops at the point.

- Counter action
 - 1) Cleared to 0 at the start of measurement.
 - 2) It is incremented or cleared by the control information from the trigger function.
 - 3) The matching information between the counter comparison setting value and the counter current value is used as a trigger factor for counter matching.
 - 4) If the current value overflows, it continues counting from 0.

- Frame counter (Ch1/Ch2) action
 - 1) Cleared to 0 at the same time as measurement starts.
 - 2) Each time a frame (CAN/CAN FD) is received, it is incremented by 1. (Maximum value is 4294967295)

■ Timer/counter settings

Tap “Trigger” for each mode and tap “Settings” in the timer/counter item on the trigger summary screen to display the settings screen.

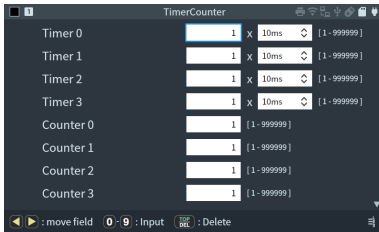

For the timer, select the comparison setting value from 1 to 999999 and the resolution from 100ms, 10ms, or 1ms.

Set the comparison setting value for the counter in the range of 1 to 999999.

Chapter 8 Translation function

8.1 Outline

Translation function displays the detailed information in the CAN/CAN FD frames such as the physical values. And, the translated values can be displayed in graph.

- Available for version 1.11 or above.
- LINEEYE does not warrant that all “.dbc” files can be loaded to the analyzer.
- Cannot make the “.dbc” file by the analyzer.

In addition, J1939 can be translated without loading the translation definition.

- Available for version 1.15 or above.

8.2 Setting

Tap “translation” and set translation settings.

- This setting is for data display only. If changing the translation settings, it will apply to the data in the capture buffer and “.DT” data loaded from the files. However, translated data cannot be output to “.DT” or “.SU” files.

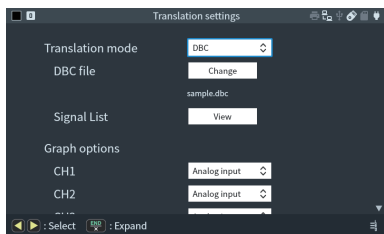

◆ Translation mode

Select from “None”, “DBC” or “J1939”. When “DBC” or “J1939” is selected, the following related options are displayed.

[When DBC translation mode is selected]

◆ DBC file

Insert the USB memory or SD card, which save “.dbc” files used for translation. Tap “Register” or “Change” to display the list of DBC files. Select the applicable “.dbc” file and tap “Load File”.

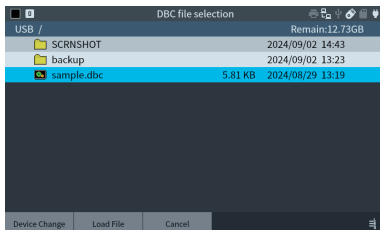

- 📄 Able to register only one “.dbc” file. The last loaded “.dbc” file is valid.
- 📄 If changing the “.dbc” file, graph setting will be initialized.

◆ Signal List

Tap “display” to display the list of signals in the order of CAN ID. Signal name and the unit (max./ min.) are also displayed. All frames registered here will be the target of translation in the frame display.

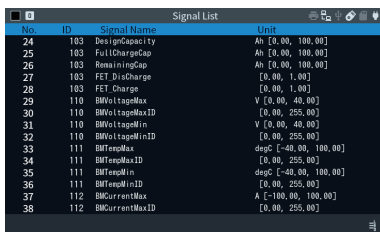

| No. | ID | Signal Name | Unit |
|-----|-----|----------------|-----------------------|
| 24 | 103 | DesignCapacity | Ah [0.00, 100.00] |
| 25 | 103 | FullChargeCap | Ah [0.00, 100.00] |
| 26 | 103 | RemainingCap | Ah [0.00, 100.00] |
| 27 | 103 | FET_Discharge | [0.00, 1.00] |
| 28 | 103 | FET_Charge | [0.00, 1.00] |
| 29 | 110 | BMVotageMax | V [0.00, 40.00] |
| 30 | 110 | BMVotageMaxID | [0.00, 255.00] |
| 31 | 110 | BMVotageMin | V [0.00, 40.00] |
| 32 | 110 | BMVotageMinID | [0.00, 255.00] |
| 33 | 111 | BMTempMax | degC [-40.00, 100.00] |
| 34 | 111 | BMTempMaxID | [0.00, 255.00] |
| 35 | 111 | BMTempMin | degC [-40.00, 100.00] |
| 36 | 111 | BMTempMinID | [0.00, 255.00] |
| 37 | 112 | BMCurrentMax | A [-100.00, 100.00] |
| 38 | 112 | BMCurrentMaxID | [0.00, 255.00] |

[When DBC translation mode / J1939 translation mode is selected]

◆ Graph options

Graph for analog input can be changed to the value of CAN frame translation. It is possible to set each 8 channels (CH1 to CH8).

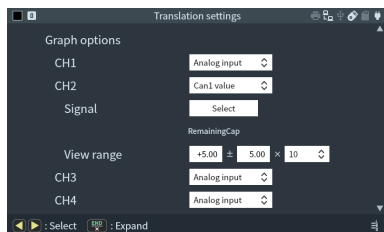

◆ CH1 ~ CH8

Analog input: Analog value of target channel will be displayed in graph

CAN1 value: Translated value of specified signals measured in CAN CH1 will be displayed in graph.

CAN2 value: Translated value of specified signals measured in CAN CH2 will be displayed in graph.

◆ Signal (DBC translation mode only)

Tap “Select” to display Signal Selection display.

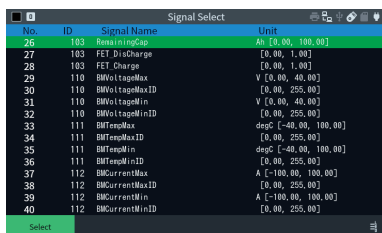

Move the cursor (highlighting in green) and tap “Select”.

☰ If selecting nothing, “Analog input” will be selected.

◆ J1939 SP (J1939 translation mode only)

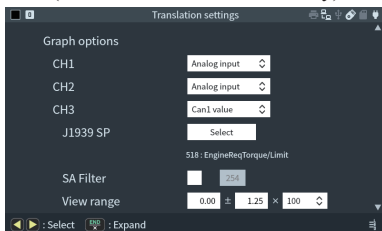

When you tap “Select”, the J1939 SP selection screen will be displayed. Scroll the green cursor to the SP (Suspect Parameter) you want to plot in the graph, and tap “Select”.

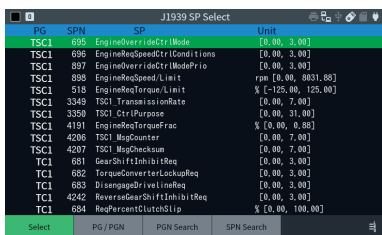

Tapping “PG/PGN” switches the display content of the leftmost item between PG (Parameter Group) abbreviation/number notation.

Tapping “PGN Search” displays a dialog where you can enter a PGN (Parameter Group Number) to jump to the display position. If a matching PGN is not found in the list of available translation graphs, it will jump to the position with the closest number.

Tapping “SGN Search” displays a dialog where you can enter an SPN (Suspect Parameter Number) to jump to the display position.

◆ SA Filter (J1939 Translation Mode Only)

Check the box on the left to filter and display only frames with the specified SA (source address) in the box on the right as a graph.

◆ View range

Set the default range. The setting range will be the maximum range and used to zoom the data in the graph.

If the selected translation target has maximum/minimum value definitions, the range will be set automatically when selected, but you can adjust it manually if necessary. Set the combination of the center value and width of the vertical axis.

Example)

“minimum -200”and “maximum 200” : $+0.00 \pm 2.00 \times 100$

“minimum 0”and “maximum 100” : $+5.00 \pm 5.00 \times 10$

8.3 Screen display

■ Frame view

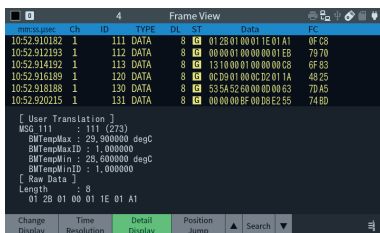

“Detailed frame window” will be displayed on the bottom of frame view by tapping “Detail Display” while using the On-line monitor or Manual simulation function. Tap it again to hide the display.

In DBC translation mode, the [User Translation] item appears only for frames that are to be translated by the loaded .dbc file, and the translation results are listed.

In J1939 translation mode, the translation results are listed for frames that are to be translated (extended ID data frames and CAN FD frames).

☞ “Detailed frame window” will not be displayed while scrolling or using the split display.

■ Analog graph display

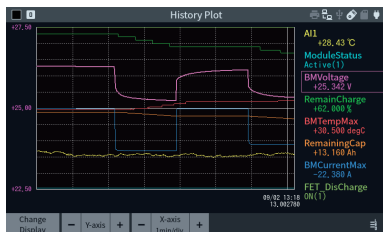

If selecting “CAN1 value” or “CAN2 value” in the translation graph display setting, CAN translation data will be displayed in the analog graph display.

There are signal name, value on the cursor, and unit are displayed on the right side of the graph. Other operations are same as normal analog graph display.

4.2.2 Analog graph display

- Notes of displaying analog value and CAN translated value on the graph

Display update may slow down with extremely different cycle between the analog data and the CAN translation data.

Set the analog sampling rate as close as the CAN message cycle to be translated in order to improve the performance.

8.4 J1939 Translation

The following items are translated by this unit.

J1939-21 (Data Link Layer) Rev.2022-05

J1939-22 (CAN FD Data Link Layer) Rev.2022-09

J1939-DA (Digital Annex) Rev.2025-03 *

* Supports translation of approximately 4000 SPNs in the ranges of PGN 0 to 61494 and 64778 to 65279. (As of system version V1.15)

It also supports translation of TP (Transport Protocol) which transmits more than 9 bytes of data in J1939-21, and J1939-22 Multi-PG and FD.TP.

However, for the following, only detailed translation display is supported on the frame display screen, and real-time graph display is not possible.

- Data with a variable number of elements
- Character string data
- Data that spans multiple frames (TP, FD.TP)

Some content has been abbreviated to fit within the limited display space on this unit.

For more accurate information, please refer to the respective specifications.

Chapter 9 Save and Load of the Data

Tap “File Manager” on the top menu screen to save and read measurement data on the file management screen.

For operating instructions and details, please refer to the LE-8600X series and LE-8500X series instruction manual “Save and Load of the Data”.

9.1 Export data function

You can save the current display data in text format (.txt or .csv). Tap [SHIFT]+“Export” on the file manager screen to display the data export dialog.

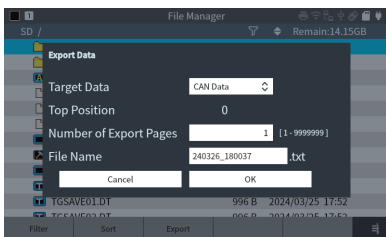

◆ Target Data

Select the data to be output from from CAN data (frame display screen), analog data , GPS data, or analog waveform.

◆ Top Position

Displays the current top position of the display data on the screen.

◆ File format

- When the target data is “CAN data,,” you can select the output format from txt format or pcap format.
The pcap format can be read and analyzed using free software such as Wireshark.
- For “analog data”: select “txt” or “csv” format.
- For “GPS data”: select “txt”, “csv”, or “kml” format. “kml” format is widely used for Google application and so on.

◆ Number of Export Pages

Enter how many pages to output from the current starting position.

One page has 66 lines.

Depending on the combination of target data and file format, this item may not be displayed, and the entire recorded data will be output.

◆ File Name

Enter the file name.

Tap “OK” or press [ENTER] to save it to the storage device.

■ CAN/CAN FD data

Example of data export

```
f=[LE-8600X]===[2024-02-08 14:55:41]=*
f Model      : LE-8600X          *
f Version    : x.xx.xx          *
f Extension  : SB-C2AN          *
f Serial No. : xxxxxxxx         *
f Start time : 2024-02-08 14:55:15 *
f Stop time  : 2024-02-08 14:55:16 *
f-----*
f MONITOR DATA (FRAME)        *
f CH1 PROTOCOL: CAN/CAN FD(ISO) *
f   BAUDRATE: 1M                *
f   BAUDRATE(DATA): 5M          *
f CH2 PROTOCOL: CAN/CAN FD(ISO) *
f   BAUDRATE: 1M                *
f   BAUDRATE(DATA): 5M          *
f-----*

---MM:SS.uSEC---CH---ID--TYPE---DL-ST-DATA-----FC--
30:27.407667  1    111 FDATA*  64 G 5555555555555555 05D886
      +8: 5555555555555555 5555555555555555
      +24: 5555555555555555 5555555555555555
      +40: 5555555555555555 5555555555555555
      +56: 5555555555555555
30:27.407667  2    111 FDATA*  64 G 5555555555555555 05D886
      +8: 5555555555555555 5555555555555555
      +24: 5555555555555555 5555555555555555
      +40: 5555555555555555 5555555555555555
      +56: 5555555555555555
30:27.696340  1    123 DATA    8 G 5555000066662222 59A1
30:27.696340  2    123 DATA    8 G 5555000066662222 59A1
```

■ Analog input data

Example of data export

```
*=[LE-8600X]====[2024-02-08 14:55:48]=*
* Model      : LE-8600X                *
* Version    : x.xx.xx                 *
* Extension   : SB-C2AN                 *
* Serial No. : xxxxxxxx                 *
* Start time  : 2024-02-08 14:55:15    *
* Stop time   : 2024-02-08 14:55:16    *
*-----*
* MONITOR DATA (ANALOG)                *
* INPUT PORT : ON-BOARD BNC            *
* SAMPL.PERIOD: 1ms                     *
* IMPEDANCE  : 1Mohm                    *
* CH1 RANGE  : -5V - +5V                *
* CH2 RANGE  : -5V - +5V                *
*-----*

--MM:SS.uSEC-----A11-----A12--
01:51.978746 +2.8716 +2.8469
01:51.977746 +2.8716 +2.8474
01:51.978746 +2.8720 +2.8472
01:51.979746 +2.8717 +2.8477
01:51.980746 +2.8720 +2.8475
01:51.981746 +2.8718 +2.8467
01:51.982746 +2.8714 +2.8472
01:51.983746 +2.8719 +2.8468
01:51.984746 +2.8716 +2.8471
01:51.985745 +2.8717 +2.8471
```

■ GPS positioning data

Example of data export

```
*=[LE-8600X]====[2024-02-08 14:55:52]=*
* Model      : LE-8600X                *
* Version    : x.xx.xx                 *
* Extension   : SB-C2AN                 *
* Serial No. : xxxxxxxx                 *
* Start time  : 2024-02-08 14:55:15    *
* Stop time   : 2024-02-08 14:55:16    *
*-----*
* MONITOR DATA (GPS)                   *
*-----*

--MM:SS.uSEC-----UTC---Q-N---LATITUDE-----LONGITUDE---ERR[m]---ALT[m]-
30:26.806617 06:31:00 G 15 N34 58.82786 E135 43.98439 7.30 35.85
30:27.806623 06:31:01 G 14 N34 58.82775 E135 43.98452 7.23 35.81
30:28.806629 06:31:02 G 14 N34 58.82765 E135 43.98470 7.14 35.83
30:29.806634 06:31:03 G 14 N34 58.82756 E135 43.98487 7.06 35.84
30:30.806638 06:31:04 G 13 N34 58.82749 E135 43.98500 6.99 35.84
30:31.816634 06:31:05 G 14 N34 58.82751 E135 43.98518 6.93 36.02
30:32.816641 06:31:06 G 14 N34 58.82744 E135 43.98529 6.88 35.99
30:33.816647 06:31:07 G 14 N34 58.82727 E135 43.98540 6.83 35.99
```

Chapter 10 Printout function

Measurement data can be printed out or a hard copy of the screen can be output to a dedicated printer SM4-31W (optional) connected to this device via USB or wireless LAN. For information on how to connect to a printer and how to operate it, please see “Printout Function” in the LE-8600X/LE-8500X series instruction manual. Display data of CAN data (frame display screen), analog data (analog display screen), and GPS data (GPS data display screen) can be printed out in the same format as when saving files in text format to external storage. Please refer to Chapter 8 for export examples.

9.1 Export data function

Chapter 11 Specification

| Item | SB-C2AN |
|---|--|
| Applicable analyzer | LE-8600Xseries, LE-8500Xseries |
| CAN FD/CAN measurement port | ISO11898/ISO11898-1:2015 (Dsub 9pin male connector, inch screw #4-40) |
| Channel Transceiver | 2 channels can be measured simultaneously MCP2542FD (Microchip) or equivalent |
| High-speed analog measurement port | Number of channels: 2, built-in 12bit resolution/100MSPS high-speed ADC (BNC connector x 2) |
| Input impedance | 1M Ω , 50 Ω can be selected, withstand voltage: max. ± 30 Vpk (at 1M Ω), max. ± 6 Vpk (at 50 Ω) |
| withstand voltage | |
| Input range | ± 24 V, ± 12 V, ± 5 V, ± 2.5 V |
| External trigger/Extended analog measurement port | External trigger input/output, expansion analog pod connection port (MIL 10 pin connector) |
| Analog pod OP-8AH (standard equipment) | Number of channels: 8, built-in 24-bit resolution ADC, screwless terminal block |
| Input impedance | 1M Ω , withstand voltage: max. ± 65 Vpk, |
| withstand voltage | GND common between channels, non-isolated |
| Input range | ± 60 V, ± 30 V, ± 16 V, ± 8 V, ± 4 V |
| Measurement accuracy ^{*1} | ± 60 V range, ± 30 V range, ± 16 V range : $\pm (0.1\% \text{ rdg} + 3\text{mV})$ ± 8 V range, ± 4 V range : $\pm (0.1\% \text{ rdg} + 2\text{mV})$ |
| Analog pod OP-8AT (optional) | Number of channels: 8, 24-bit resolution, built-in high-precision ADC, screwless terminal block |
| Input impedance | 1M Ω , withstand voltage: max ± 50 Vpk |
| voltage resistance | |
| Signal isolation voltage | Between analog input and analyzer 1500V (AC peak/DC) Between each channel of analog input 350V (AC peak/DC) |
| Input range ^{*2} | ± 30 V, ± 10 V, ± 1 V, ± 100 mV, 0-20mA, temperature K, J, T, E, N, R, S, B type thermocouple compatible |
| Measurement accuracy ^{*3} | ± 30 V range $\pm (0.05\% \text{ rdg} + 3\text{mV})$, ± 10 V range $\pm (0.05\% \text{ rdg} + 2\text{mV})$, ± 1 V range $\pm (0.05\% \text{ rdg} + 0.2\text{mV})$, ± 100 mV range $\pm (0.05\% \text{ rdg} + 50\mu\text{V})$, 0-20mA current range $\pm 0.05\% \text{ FS}$, Temperature range: See below table |
| Monitor function | Displays and records ID, type, content, error, and CRC of CAN/CAN FD communication frame. CAN/CAN FD sampling point (60% to 90%) can be set. |
| Extended protocol | CAN-FD(ISO/Non-ISO), CAN2.0B, DeviceNet ^{*4} |
| Communication speed | CAN : 20kbps to 1Mbps CAN FD: 20kbps ~ 1Mbps BRS ON data field 1Mbps ~ 5Mbps (Arbitrary speed setting is available) |
| Capture memory | Uses the analyzer's capture memory ^{*5} , auto-save to external storage is available |
| ID filter | Only the specified standard/extended ID (bitmask can be specified) frame can be recorded for each channel |
| Error checking function | CAN/CAN FD: ACK error, form error, CRC error, error frame |

| | |
|--|--|
| Timestamp | Records frame reception time (time resolution 1 μ s) Can switch display between real time (year, month, day, hour, minute, second, μ second), elapsed time from start of measurement, and difference time from previous frame. GNSS/GPS signal or Time synchronization via external PPS signal is possible. |
| Trigger function | OR operation and sequence operation are possible by specifying up to 8 sets of conditions and operations |
| Trigger condition | Error (non-ACK, ERROR frame, CRC), specified data frame (channel, ID, data, data offset, data bit mask), specified remote frame (channel, ID), timer match, counter match, external trigger input |
| Trigger action | Stop measurement, save measured data to SD card/USB storage, timer control, counter control, send specified data, buzzer, enable/disable trigger conditions, external trigger output |
| Simulation function | Transmission test of pre-registered test frames (CAN/CAN FD: 272 types) is possible. Can automatically increase/decrease (sweep) the specified position data in the data field. ⁶ Multiple frames selected by key operation can be sent at each specified period (the number of transmissions can also be specified). |
| Retrieval function | Search for error, frame with specified ID and data (up to 8 characters, don't care and bit mask can be specified, offset from the beginning of frame to judgment data can be specified), real time timestamp in specified range, trigger match data can be searched and counted, mark jump to frame pointer possible |
| Analog measurement (Analog logger) function | Records the analog value of the specified analog measurement port at specified intervals and displays graph/numeric values |
| Recording mode | It is possible to select between analog independent measurement and parallel measurement with CAN/CAN FD monitor function, and the related display of communication data and analog values based on time stamps is possible. |
| Recording cycle | When selecting high-speed analog measurement port: 10 μ seconds to 100m seconds, when selecting analog pod OP-8AH: 62.5 μ sec to 100ms, when selecting analog pod OP-8AT: 10m seconds to 1 minute ⁷ |
| Analog waveform monitor (oscilloscope) function | Measure the voltage of the CH1 differential signal line of BNC connector x2 or CAN/CANFD at the sampling clock cycle and display the waveform |
| Sampling Clock | 20KHz to 100MHz (12 steps) |
| Sampling memory | Maximum 32,768 sampling |
| Trigger mode | Measurement can be stopped according to the position setting after trigger conditions are met, and waveform display can be selected repeatedly after trigger conditions are met |
| Trigger condition | Voltage level (rising/falling) of specified input channel, match of specified trigger condition of online monitor function |
| Trigger position | Before (emphasizes before the trigger), Center (center), After (emphasizes after the trigger) |
| Other features | Enlarged/reduced display, voltage/time measurement function between cursors |
| Digital waveform monitor (Logic analyzer) function | Measures logical changes in CAN/CAN FD communication signal lines at sampling clock cycles and displays waveforms |
| Sampling Clock | 1KHz ~ 100MHz(steps) |

| | |
|-------------------------------|---|
| Sampling memory | Maximum 4,096 sampling |
| Trigger mode | You can choose to wait for the trigger condition immediately after measurement, or wait for the trigger condition after the sampling memory is fully recorded |
| Trigger condition | Logical state match of CAN/CAN FD communication signal line, match specified trigger condition of online monitor function |
| Trigger position | Before (emphasizes before the trigger), Center (center), After (emphasizes after the trigger) |
| Trigger pass count | You can specify the number of times (0 to 9999) to pass (ignore) trigger condition matching |
| Other features | Enlarged/reduced display (10 steps), time measurement function between cursors, signal line swapping function, signal status search function |
| GPS function | Equipped with SMA (female) connector for active GPS antenna connection Timestamps can be synchronized to UTC time with high precision Can record and display latitude, longitude, height above sea level, etc. in parallel with CAN/CAN FD communication data and analog measurement values. QZSS SLAS (submeter class positioning augmentation service) compatible Output GPS data in “kml” format.*8 |
| DBC translation function *8 | It can read DBC files and translate CAN/CAN FD frames, can display translation results of selected signals (up to 8 types) in real-time graphs along with analog measurement values |
| J1939 translation function *9 | It can translate and display approximately 4000 SPNs, supports J1939-22 (CAN FD), can display translation results of selected SPs (up to 8 types) in real-time graphs along with analog measurement values |
| Other features | Auto save function, automatic backup function, automatic time specified RUN/STOP function, file management function, text conversion function (txt format, csv format), printout function |
| Temperature range | Operation: 0~40°C Save: -20~50°C |
| Humidity range | 20 to 85%RH (no condensation) |
| Components | Interface sub board 1 piece, DSUB9 pin branch cable 1 piece, passive probe 2 pieces, high-speed high voltage analog measurement pod (OP-8AH) 1 piece, pod connection cable 1 piece, quick start guide, warranty card |

*1 : rdg represents the accuracy of the reading.

*2 : For the 0-20mA range, an external current detection resistor (250Ω or 50Ω, accuracy±0.1% or less) is required on the input terminal block. is.

*3 : rdg represents the accuracy for the reading value, and FS represents the accuracy for the full scale of the range. Current accuracy does not include external resistance errors.

*4 : Only raw data can be displayed.

*5 : The main body capture memory is consumed as a recording area for CAN/CAN FD communication data, analog measurement values, and GPS data.

*6 : Endian, initial value, three-step target value, and the time to target can be specified.

*7 : The 10ms cycle of analog pod OP-8AT is only possible when the number of measurement channels is 1.

*8 : Requires system version V1.11 or later.

*9 : Requires system version V1.15 or later.

| OP-8AT (optional) temperature measurement specifications | | |
|--|--|--|
| Compatible thermocouple | K, J, T, E, N, R, S, B Type | |
| Measurement temperature range | K Type : -200°C ~ 1370°C J Type : -210°C ~ 1200°C T Type : -200°C ~ 400°C E Type : -200°C ~ 1000°C N Type : -200°C ~ 1300°C R Type : 0°C ~ 1760°C S Type : 0°C ~ 1760°C B Type : 400°C ~ 1800°C | |
| Cold junction compensation | Internal compensation, external compensation switchable | |
| Disconnection detection function | On/off switchable (applied current: approx. 180nA) | |
| Measurement accuracy ^{*1} | K Type | -50°C ~ 1370°C : ±(0.05% rdg + 1.0°C) -200°C ~ -50°C : ±(0.05% rdg + 2.0°C) |
| | J Type | -50°C ~ 1200°C : ±(0.05% rdg + 0.8°C) -210°C ~ -50°C : ±(0.05% rdg + 1.6°C) |
| | T Type | -50°C ~ 400°C : ±(0.05% rdg + 1.0°C) -200°C ~ -50°C : ±(0.05% rdg + 2.0°C) |
| | E Type | -50°C ~ 1000°C : ±(0.05% rdg + 0.6°C) -200°C ~ -50°C : ±(0.05% rdg + 1.2°C) |
| | N Type | -50°C ~ 1300°C : ±(0.05% rdg + 1.5°C) -200°C ~ -50°C : ±(0.05% rdg + 3.0°C) |
| | R Type | 400°C ~ 1760°C : ±(0.05% rdg + 3.5°C) |
| | S Type | 0°C ~ 400°C : ±(0.05% rdg + 6.0°C) |
| | B Type | 800°C ~ 1800°C : ±(0.05% rdg + 4.0°C) 400°C ~ 800°C : ±(0.05% rdg + 7.5°C) |
| | Cold junction compensation accuracy ^{*2} | ± 1.0°C |

*1 : Accuracy at ambient temperature of 18 to 28°C and after 20 minutes after power on, does not include thermocouple error.

If the above ambient temperature range is exceeded, add 1/20 of each error value for every 1°C.

*2 : In environments where a part of the measurement pod is locally heated or cooled, cold junction compensation accuracy cannot be guaranteed.

Chapter 12 After Support and Maintenance

12.1 Factory reset

By the Factory reset operation, you can initialize the internal status of this analyzer and return the settings to the factory settings.

■ How to

Tap “Factory reset” on the “Version” tab of “System Settings”. If you tap “OK” in the confirmation message, the main unit will automatically shut down and the settings will be initialized when you boot it next time.

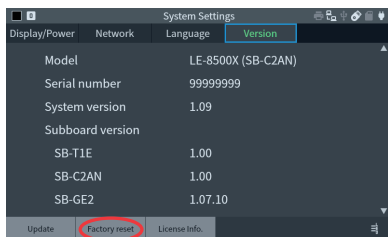

12.2 Probe compensation

Probe compensation is required when measuring with a 10x passive probe. Perform this when using the probe for the first time or when changing the connected channel.

Without this, measurement results may be inaccurate.

◆ Connection

The compensation signal (1kHz square) is output from the trigger output terminal.

Connect the probe tip to the TRG OUT (external trigger output) of the external trigger/extension analog measurement port or the trigger connection terminal (OUT) of each expansion pod.

Connect the ground lead to the GND (signal ground) of the expansion pod connector or to the trigger connection terminal (GND) of each expansion pod.

Use the shortest lead wire possible to connect the probe to the trigger output terminal.

At this time, connect only one probe to the trigger output terminal.



◆ Compensation procedure

- 1) Select “Analog” mode from the top menu.
- 2) Change the measurement settings using the analog waveform monitor option (Wave Opt.).
 - Enable wave monitor : Check
 - Port : BNC
 - Input impedance : $1M\Omega$
 - CH1/CH2 Range : $\pm 2.5V$
 - Sampling Clock : $5\mu s$
 - Position : Center
 - Mode : Continuous
 - Factor : Analog level
 - Channel : Channel to which the probe to be calibrated is connected
 - Slope : Rising
 - Level(V) : +0.3
 - Calibration pulse : Check
- 3) Press [RUN] to start measurement.

- 4) Tap “Change Display” twice to display the analog waveform display screen.

At this time, adjusting the Y axis to x5 and +0.250V to the center will make it easier to adjust.

- 5) Slowly rotate the trimmer adjustment knob on the tip of the probe using the included adjustment screwdriver to adjust the waveform displayed on the screen to be a neat square.

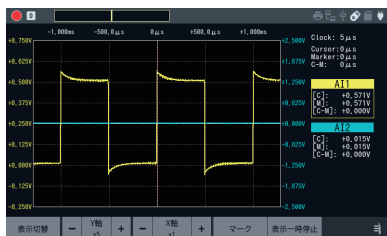

Compensation NG

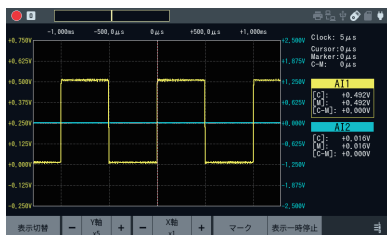

Compensation OK

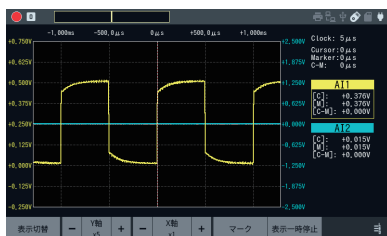

Compensation NG

- 6) When the compensation is complete, press [STOP] to end the measurement and uncheck the probe calibration signal in the analog waveform monitor option (Wave Opt.).

12.3 Warranty and After service



Warranty

- When you face any problems, please contact LINEEYE distributors or LINEEYE

- Warranty

Within a period of 12 months from the date of shipment, LINEEYE warrants that your purchased products (except consumable parts such as the battery and software) are free of charge from any defects in material and workmanship, only when the products are operated in accordance with procedures described in the documents supplied by LINEEYE.

If the defects exist during the Warranty period, please send back the products to LINEEYE distributors or LINEEYE. LINEEYE will repair or exchange them at no charge. In this case, the shipping charge will be at your own expense. The foregoing warranties are the sole warranties given by LINEEYE. Above warranties shall not be applied to the products that have been modified, repaired or altered (except by LINEEYE) or that have been subjected to unusual physical or electrical stress, misuses, abuse, negligence or accidents. LINEEYE disclaims all other warranties including the warranties of merchantability fitness for some particular purpose and noninfringement of third party right. LINEEYE cannot promise that the software is error-free or will operate without any interruption.



User Registration

User registration is required to receive appropriate after-sales support. Please register as a user using the user registration form on our website.
<https://www.lineeye.co.jp/html/support.html>

Repair

For malfunction, please contact LINEEYE distributors or LINEEYE and tell us following details.

| | |
|---------------|------------------------|
| Model | SB-C2AN |
| Serial Number | 8 digit numbers |
| Purchase Date | Year, Month, Day |
| Other | Details of malfunction |

- **Repair during warranty period**
LINEEYE repairs, following the repair instruction.
Please provide the details of malfunction.

- **Repair after warranty period**
LINEEYE will repair the products at our own expense.

- **Calibration**
Enable to have a hardware calibration test by the line monitor

After Support

Read “FAQ” in our Website or email us.
Please refer to “FAQ”. We also have support by email regarding the technical issue. When you use it, please register your product via our website.

Website : <https://www.lineeye.com>

There is a registration page on our web site.
(<https://www.lineeye.com>)
Please register your product for further support.
We will provide you the firmware update
information and sales information etc.

LINEEYE CO., LTD.

4F., Marufuku Bldg., 39-1, Karahashi Nishihiragaki-cho, Minami-ku,
Kyoto, 601-8468, Japan

Phone : 81-75-693-0161 Fax : 81-75-693-0163

URL <https://www.lineeye.com> Email :info@lineeye.co.jp

Printed in Japan

M-46C2ANE/LE