



Options for LE-8600X/LE-8500X series
Expansion kit for LAN/PoE (2ch) measurement
(EtherCAT supported)

SB-FE2

Instruction Manual

The utility CD attached to the main unit contains an English instruction manual for this expansion kit in PDF format.

Instruction

Thank you for your purchase of SB-FE2, To use it correctly, you are advised to read and understand this instruction manual thoroughly. Keep this together with the warranty. If you encounter any problems, you will find helpful information in this manual.



NOTICE

It is prohibited to reprint or duplicate any part of the whole of this instruction manual without prior permission from LINEEYE. The content of this instruction manual and specifications of the products are subject to change without any notice. This instruction manual has been designed and edited with great care to give you all necessary information. If you have any questions, feel free to direct your inquiries to LINEEYE. LINEEYE makes no warranty or guarantee, either expressed or implied with respect to its quality, performance, merchantability, or fitness for a particular purpose. LINEEYE shall not be liable for direct, in-direct, special, incidental, or consequential damages resulting from any defect in the product. The warranty and remedies set forth above are exclusive and in lieu of all others.



USER LIMITATION

This product has been developed for the purpose of using as an analyzer only. When you use this product with the following devices that are required to function with a high degree of reliability, safety and accuracy, use it under considering the safe design of the system in order to maintain reliability and safety for that system; *Devices that are directly related to transportation such as airplanes, trains, cars etc. *Devices for crime prevention and disaster privension. *Each kind of safety devices and so on. This product has not been developed for the use that needs exclusivey high reliability and safety: aerospace apparatus, trunk communication apparatus, nuclear control apparatus, medical apparatus related with life maintenance etc. Therefore, do no use for those purposes.

Safety Information

Read this first !!

This Safety Information includes the following important information in order to not only have you learn the right way to use the analyzer, but also prevent you from causing damage to people and property. Before using, please read the main contents after you understand the following symbols & marks.

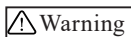

Warning

Should the device be used without following these symbols, there is a possibility of accidents, such as a death or a serious injury, occurring.

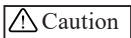

Caution

Should the device be used without following these symbols, there is a possibility of accidents, such as an injury^(*), and material damage^(**) occurring.

*1 "Injury" indicates injury, burn and electric shock, or the like which does not require hospitalization or the extended hospital visit.







*2 "Material damage" indicates damage related to a house, a building, furniture, apparatus, livestock or a pet.







Prohibition



The necessary

|  Warning | |
|---|--|
|  | <ul style="list-style-type: none">Do not disassemble, modify or repair the line monitor This may result in an injury, electric shock, and ignition. |
|  | <ul style="list-style-type: none">Do not put the analyzer in fire or heat them. This may result in a injury and fire due to overheating or explosion. |
|  | <ul style="list-style-type: none">Do not use the line monitor if there is inflammable gas. This may result in ignition and explosion. |
|  | <ul style="list-style-type: none">Turn off the power of analyzer and unplug the cables immediately when emanating smoke, odor or sound. Continuous use may result in an electric shock, injure or ignition. |
|  | <ul style="list-style-type: none">Turn off the power and unplug the line monitor immediately when liquid or foreign substance gets into the line monitor. Continuous use may result in ignition, electric shock and malfunction. |

 Caution

| | |
|--|--|
|  | <ul style="list-style-type: none">● Do not touch the line monitor with wet hand. This may result in an electric shock and malfunction. |
|  | <ul style="list-style-type: none">● Do not give a strong impact on the product, such as dropping and crashing. |
|  | <ul style="list-style-type: none">● Do not leave the analyzer in the following conditions.<ul style="list-style-type: none">• Strong magnetic field, static electricity or dusty place.• Temperature and humidity above the specification or where dew condensation appears.• Not flat, or shaking place.• Place with leaking water or electricity.• Place affected by direct sun or near the fire.<p> Please do not leave the analyzer in the car during the summer.</p> |
|  | <ul style="list-style-type: none">● Do not use at the following situations. The radio wave by the analyzer may cause trouble.<ul style="list-style-type: none">• Near a medical device such as cardiac pacemaker or hearing aid.• Near an automatic controller such as fire-alarm box or automatic door.• Near a microwave, high-level electronics, TV, or radio.• Near a wireless station for mobile communications or a specified low power radio station. |

CONTENTS

| | |
|--|-----------|
| Safety Information | 1 |
| Chapter 1 Before Using the Product | 5 |
| 1.1 Overview | 5 |
| 1.2 Unpacking..... | 5 |
| 1.3 Insert the interface board | 6 |
| 1.4 Installation of Firmware..... | 6 |
| Chapter 2 Basic Operation..... | 7 |
| 2.1 Panel Description | 7 |
| 2.2 Operation..... | 8 |
| 2.3 Line State LEDs | 8 |
| 2.4 About the capture method..... | 9 |
| 2.5 Link information..... | 9 |
| 2.6 Common functions for each board | 9 |
| Chapter 3 Online Monitor Function | 10 |
| 3.1 Outline | 10 |
| 3.2 Filter Setup | 11 |
| 3.3 Online monitor Configuration | 15 |
| 3.4 Start and Stop Measurement | 18 |
| 3.5 Display..... | 19 |
| 3.6 Retrieval Function..... | 23 |
| 3.7 Trigger Function | 26 |
| Chapter 4 PoE(Power over Ethernet) | 31 |
| 4.1 Connection..... | 31 |
| 4.2 PoE Setup | 32 |
| 4.3 Start and Stop Measurement..... | 32 |
| 4.4 Display..... | 33 |
| Chapter 5 Delay time measurement function | 35 |
| 5.1 Port Selection to Measure | 35 |
| 5.2 Start and Stop Measurement..... | 36 |

| | |
|---|-----------|
| Chapter 6 Manual Simulation Function..... | 37 |
| 6.1 Connection..... | 37 |
| 6.2 Settings..... | 37 |
| 6.3 Statistical analysis settings | 38 |
| 6.4 End..... | 38 |
| 6.5 Display..... | 39 |
| Chapter 7 Packet Difference | 40 |
| 7.1 Connection method..... | 40 |
| 7.2 Packet Difference Measurement Settings | 40 |
| 7.3 Start and End Measurements | 41 |
| 7.4 Display screen..... | 41 |
| Chapter 8 Save and Load of the Data | 43 |
| 8.1 Export data function..... | 43 |
| Chapter 9 Printout function | 46 |
| Chapter 10 Specifications..... | 47 |
| Chapter 11 After Support and Maintenance | 48 |
| 11.1 Factory reset..... | 48 |
| 11.2 Warranty and After service..... | 48 |

Chapter 1 Before Using the Product

1.1 Overview

SB-FE2 is an interface expansion kit for LE-8600X/LE-8500X series communication analyzers. By installing this expansion set interface board to a compatible model, 100BASE-TX and 10BASE-T Ethernet measurements can be performed without delay of the communication data. It is also suitable for measuring real-time Ethernet such as EtherCAT. In addition, PoE can be measured simultaneously on two channels, and PoE measurements of two devices can be performed simultaneously.

■ Features

- Easy setup by simply replacing the interface board
- Zero-delay tap that simultaneously measures two lines is ideal for EtherCAT packet measurement
- Supports PoE, PoE+, and PoE++ measurements, directly analyzes both communication data and power
- Statistical analysis function that can monitor traffic and specific frame occurrences.
- Time correction function using GNSS (PPS) signals provides accurate time stamps.
- Direct analysis of both communication and power
- Packet difference measurement function that can compare the contents of measured packets.

1.2 Unpacking

When you unpack the product, make sure of the following.

The product has not been damaged during the transit. There is not any defect on the appearance.

You have received all the standard accessories listed below.

- | | |
|--------------------------------------|---|
| • Interface board | 1 |
| • LAN cable | 2 |
| • External signal I/O cable [LE-4TG] | 1 |
| • Quick start guide | 1 |
| • Warrant | 1 |

Please contact your LINEEYE distributors if you find any damage to the product caused by transportation, or if there are accessories lacking.

1.3 Insert the interface board

Exchange the standard interface board to SB-C2AN.

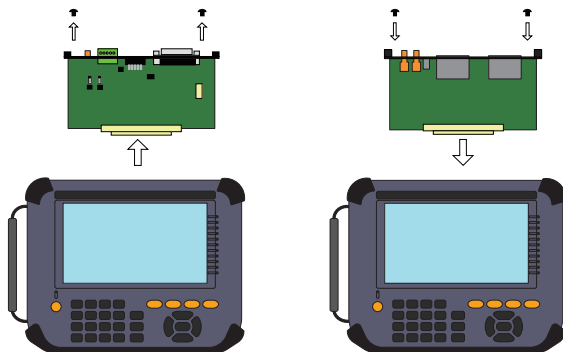

- 1) Turn off the analyzer.
- 2) Screw off M3 screws on the interface board of analyzer.
- 3) Take the board off pulling the handles of the interface board.
- 4) Insert the interface expansion board (SB-C2AN) into the slot completely
- 5) Screw it on using M3 screws.

1.4 Installation of Firmware

An applicable firmware is necessary to use SB-C2AN. If you purchase LE-8600X/ LE-8500X series before releasing the sale of SB-C2AN, update the firmware referring the instruction manual analyzer. Download the firmware file from LINEEYE webpage.

https://www.lineeye.com/html/download_update.html

Chapter 2 Basic Operation

2.1 Panel Description

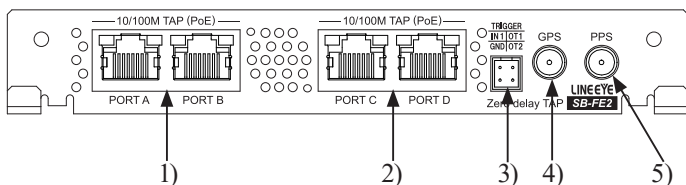

| Name | Description |
|----------------------------|---|
| 1) PORT A,B | Used for LAN measurement. The signal line is directly connected between PORT A and B internally. The line is maintained even when the power is turned off. Measurement cannot be performed on PORT A or PORT B alone. |
| 2) PORT C,D | Used for LAN measurement. The signal line is directly connected between PORT C and D internally. The line is maintained even when the power is turned off. Measurement cannot be performed on PORT C or PORT D alone. |
| 3) External Input Terminal | Input/output terminal for TTL level external signal. |
| 4) GPS antenna connector | SMA (female) connector for an active GPS antenna connection. A GPS antenna is to be connected. |
| 5) PPS signal connector | SMA (female) connector for PPS signal input/output. Used for the PPS time synchronization function. |

2.2 Operation

■ Shortcut keys

| Shortcut keys | Setting display |
|---------------|---|
| [MENU] , [0] | filter |
| [MENU] , [2] | Trigger |
| [MENU] , [3] | Online monitor |
| [MENU] , [5] | Delay Time |
| [MENU] , [6] | PoE |
| [MENU] , [7] | Statistic |
| [MENU] , [8] | Packet difference measurement setting screen |
| [MENU] , [A] | Executes the operation shown on the bottom of analyzer. (Assigned A, B, C, D, E from the left side) |
| [MENU] , [B] | |
| [MENU] , [C] | |
| [MENU] , [D] | |
| [MENU] , [E] | |

 Invalid command will be ignored. For example, pressing [Menu]+[9] while operating the Online monitor function.

2.3 Line State LEDs

Descriptions of LEDs on the right side of analyzer are following.
Tap the right bottom to display/hide the descriptions of LEDs.

| | |
|-----------|---------------------------------|
| Link AB | A/B Port Link-up |
| AB 100 | A/B Port 100BASE-TX |
| AB 10 | A/B Port 10BASE-T |
| AB Duplex | A/B Port Full Duplex connection |
| Link CD | C/D Port Link-up |
| CD 100 | C/D Port 100BASE-TX |
| CD 10 | C/D Port 10BASE-T |
| CD Duplex | C/D Port Full Duplex connection |

2.4 About the capture method

When the LE-8500X standard board (SB-GE2) captures data, the packet is first received and then sent to the opposite port. Therefore, when capturing, a delay occurs due to the time it takes for the packet to pass through the internal circuit.

This device has a through connection tap circuit between Port A-B and between Port C-D. Therefore, it will not cause any delay in the communication line. The monitor line captures frames using a signal branched from the through connection.

2.5 Link information

The PHY installed in this unit does not link with the device being measured. This unit determines the link content from the contents of the LCW (Link Code Word) sent and received during auto-negotiation between the devices being measured.

This unit estimates link information from the contents of the LCW (Link Code Word) sent and received during auto-negotiation between the devices being measured.

If the devices being measured are already linked when the power is turned on, the internal PHY cannot correctly determine the link information. Therefore, even if the measurement target devices are communicating with each other in full duplex, the Full Duplex Connection LED may not light up.

2.6 Common functions for each board

Unless otherwise noted, the “File Management”, “Recording Control”, “System Settings” and Date and Time Display at the bottom of the top menu screen are common to the LE-8600X series and LE8500X series. Please refer to “Basic Operation and Set-up” in the LE-8600X series and LE-8500X series instruction manual.

Chapter 3 Online Monitor Function

Online monitor function is to capture LAN frames passing over a network along with time stamp information of the frame and record it into the Buffer memory.

Select “Online” from Mode on the top menu screen.

3.1 Outline

Connect the LAN cables (in which the communication data between the target devices run) with each port as follows. When you need additional port cables for branch connection, use the attached LAN cable or a straight cable of the category 5e or later.

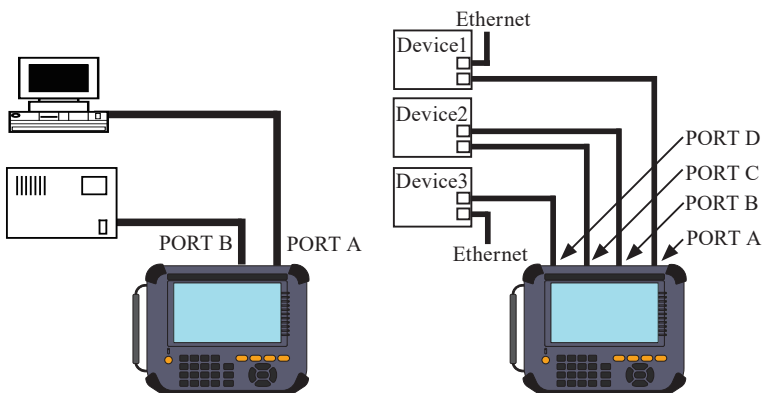

When you monitor 2 ports .

When you monitor 4 ports of EtherCAT etc

When it is in online-monitoring, it will be as shown in the figure below.

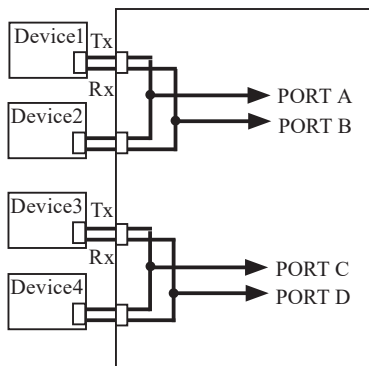

Tx between TAP A-B is recorded as PORT A, Rx as PORT B, Tx between TAP C-D is recorded as PORT C, and Rx as PORT D.

* With devices using Auto MDI-X, which device will use the Tx and Rx signals to transmit is determined randomly. Therefore, even if a device appears to be connected to PORT A, it will be recorded as PORT B if it uses the Rx signal to transmit.

3.2 Filter Setup

From the online monitor mode screen, tap “Filter” to set the filter conditions for capturing only specific frames.

Filters can also be set individually for Tx and Rx.

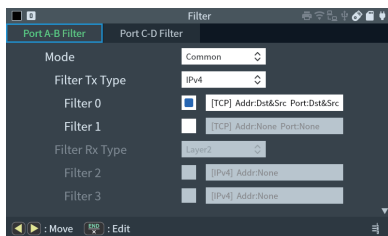

■ Mode

Select the filter configuration mode for Rx .

Common : Applies the configuration of Tx.

Separate : Applies the configuration of Rx.

 The configuration for Rx is available when you select Separate.

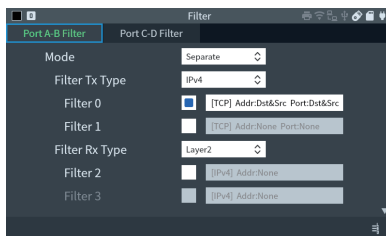

■ Type

Select the filter type.

Layer2 : Layer 2 field

IPv4 : IP(Version4) field

■ Filter

Select valid/invalid of the filter.

 When the filter of smaller number is No effect the filter of larger number also turns to be No effect.

e.g.) When the filter 0 is No effect, the filter 1 also turns to be No effect.

<IPv4>

Set the conditions of IP header for IPv4 frame.Type

■ Protocol Field

Select the protocol field from ICMP, IGMP, TCP, UDP, Custom (specify the number) and All.

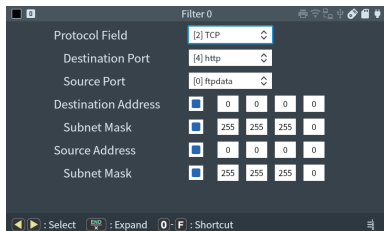
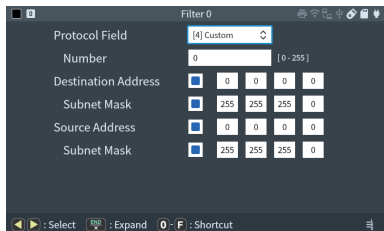

■ Number

Input the protocol number, in the case of the selecting “ Custom ” at “ Protocol field ” .

■ Destination Port

Input the destination port number when TCP or UDP is selected in the Protocol field.

■ Source Port

Input the source port number when TCP or UDP is selected in the Protocol field.

 If the option is added to the IP header of the frame, the function of “source Port” and “Destination Port” will not work properly

■ Destination Address

If checked, you can specify the destination (Dst) address.

■ Source Address

If checked, you can specify the destination (Src) address.

■ Subnet Mask

You can specify it by checking it.

The target range is the network address obtained from the bitwise AND of this value and the destination (Dst) and destination (Src) address specified values.

<Layer2>

Set the conditions of MAC header for target frame.

■ Type Field

Select the type field from IPv4, ARP, NetBios, IPv6, EtherCAT, Custom (number specified), ALL (not specified).

■ Type Field

Input the type number, in the case of the selecting “Custom” at “Type field” .

■ Destination Address

If checked, you can specify the destination (Dst) address.

■ Source Address

If checked, you can specify the source (Src) address.

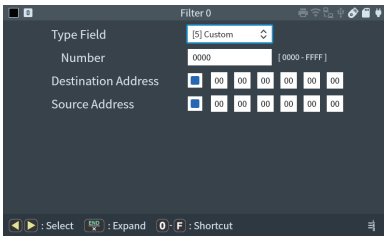

<Example of IPv4 setting>

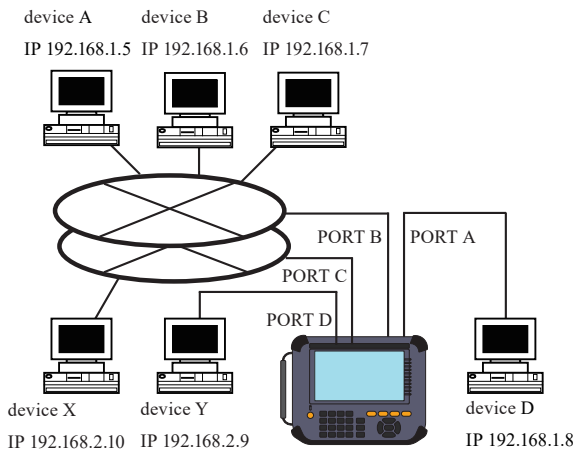

- Monitoring example of TCP/IP frames between Device A and D by filtering.

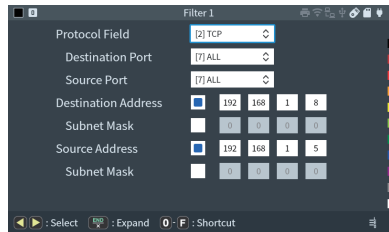
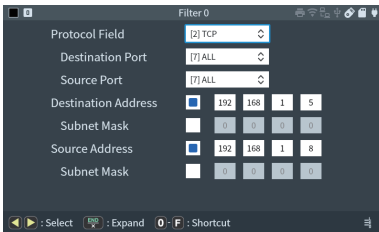
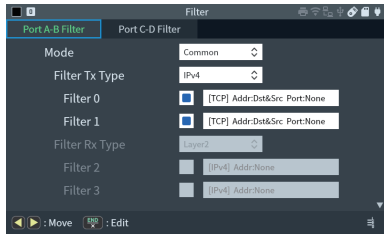

The filter 0 is configured to monitor TCP frames sent from the device D to device A and the filter 1 is configured to monitor TCP frames sent from the device A to device D. Configures this setting between port A-B.

- An example of the configuration to monitor only the UDP protocol communication between the devices X and Y which belong to the network address “192.168.2”

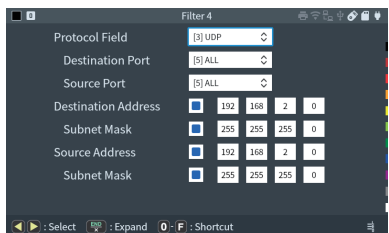
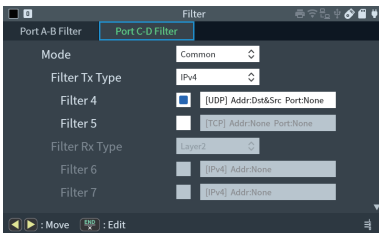

It is configured by filter 4 to monitor only the frames of UDP protocol which have “192.16.2” for the network address part of both source IP and destination IP.

3.3 Online monitor Configuration

From the online monitor mode screen, tap “Online Opt.” to enter the settings screen for data recording

■ Timestamp Resolution

Records the time when the packet is received. Select the resolution from 10us/1us/8ns. When you execute a long-term measurements, the internal 46-bit counter may go around with the minimum resolution setting. In that case, set the resolution coarsely.

[Maximum measurement time]

8ns : about 6.5 days

1us : about 2.2 years

10us : about 22 years

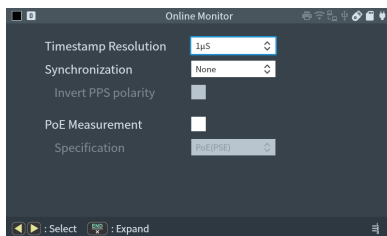

■ Synchronization

Set when synchronizing the time stamp to a certain condition.

None Uses the built-in RTC of analyzer

GPS time Synchronize with PPS signal obtained from GPS

Ext. PPS Synchronizes with the PPS signal input from the PPS terminal

📄 When either synchronization is enabled, it takes 3 to 4 seconds to actually start the measurement because the synchronization work starts at the start of the measurement.

If a valid PPS signal cannot be received during that time, an error will occur and the measurement will not start. Be especially careful when using the automatic measurement function.

📄 For external PPS synchronization, the measurement start time is the positive second (00 seconds .00000000) closest to the current internal clock time.

If you want to synchronize the data time stamp with UTC as well as the relative time after the start of measurement, you need to set the built-in clock to an error of less than 0.5 seconds in advance using NTP etc.

■ Invert PPS polarity

When not checked, the time will be adjusted by detecting the falling edge. Do not check when the PPS signal is output by another LE-8500X series or a PPS signal output device that outputs the time at the falling edge.

Check this when using a PPS signal output device that outputs the time at the rising edge.

■ PoE Measurement

PoE measurement is performed at the same time with the measurement of Ethernet LAN communication frame.

📄 For simultaneous PoE measurement, the PoE measurement cycle is fixed at 20msec.

📄 Depending on the Ethernet LAN communication data rate, the number of PoE data points drawn in the data view may be temporarily reduced.

■ Specification

Select the PoE specification.

📖 Chapter 4 PoE(Power over Ethernet)

< About connection and setting of time stamp synchronization function >

The timestamp synchronization feature has the following connections.

■ Synchronize by GPS antenna

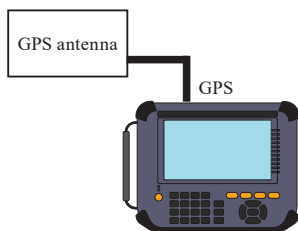

Synchronizes the LE-8500X's time stamp using a GPS active antenna. Then optional GPS active antenna is needed.

Set "GPS time" to "Synchronization" on LE-8500X.

■ Share GPS antenna with two units

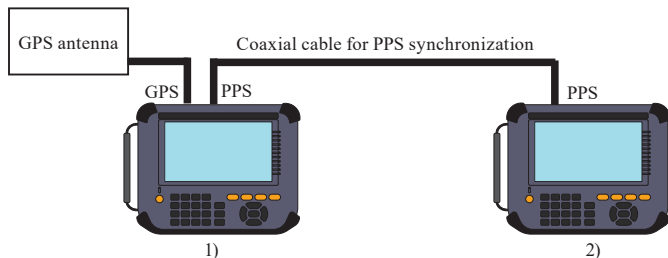

Synchronizes the time stamps of two LE-8500Xs with one GPS active antenna.

Optional GPS active antenna and PPS cable are needed.

For LE-8500X 1), set “GPS time” to “Synchronization”.

For LE-8500X 2) set “Ext. PPS ” to “Synchronization”.

Also, uncheck “Invert PPS polarity”.

 Do not connect the GPS antenna to 2).

■ Usage of an external PPS device

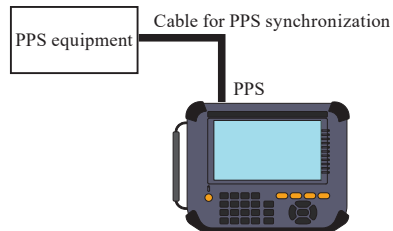

To synchronize the time stamp of LE-8500X with the PPS signal output device, an optional PPS cable is needed.

For LE-8500X set “Ext. PPS” to “Synchronization”.

Check “Invert PPS polarity” according to the PPS signal output device to be used.

 Do not connect a GPS antenna.

3.4 Start and Stop Measurement

■ Starting measurement

Press [RUN]. The display at the top left of the screen changes from “■” to “●”, and the data is captured in the capture buffer.

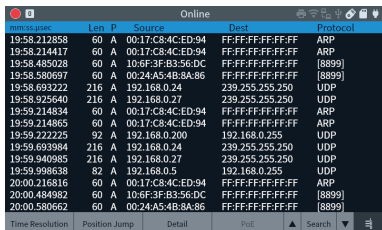

The screenshot shows a network capture tool interface with a table of captured packets. The table has columns for Time, Len, P, Source, Dest, and Protocol. The data is as follows:

| Time | Len | P | Source | Dest | Protocol |
|--------------|-----|---|-------------------|-------------------|----------|
| 19:58.212858 | 60 | A | 00:17:C8:4C:ED:94 | FF:FF:FF:FF:FF:FF | ARP |
| 19:58.214417 | 60 | A | 00:17:C8:4C:ED:94 | FF:FF:FF:FF:FF:FF | ARP |
| 19:58.485028 | 60 | A | 10:6F:3F:B3:56:DC | FF:FF:FF:FF:FF:FF | [8899] |
| 19:58.508697 | 60 | A | 00:24:A5:4B:8A:86 | FF:FF:FF:FF:FF:FF | [8899] |
| 19:58.693222 | 216 | A | 192.168.0.24 | 239.255.255.250 | UDP |
| 19:58.925640 | 216 | A | 192.168.0.27 | 239.255.255.250 | UDP |
| 19:59.214834 | 60 | A | 00:17:C8:4C:ED:94 | FF:FF:FF:FF:FF:FF | ARP |
| 19:59.214865 | 60 | A | 00:17:C8:4C:ED:94 | FF:FF:FF:FF:FF:FF | ARP |
| 19:59.222225 | 92 | A | 192.168.0.200 | 192.168.0.255 | UDP |
| 19:59.693984 | 216 | A | 192.168.0.24 | 239.255.255.250 | UDP |
| 19:59.940985 | 216 | A | 192.168.0.27 | 239.255.255.250 | UDP |
| 19:59.998638 | 82 | A | 192.168.0.5 | 192.168.0.255 | UDP |
| 20:00.216816 | 60 | A | 00:17:C8:4C:ED:94 | FF:FF:FF:FF:FF:FF | ARP |
| 20:00.484982 | 60 | A | 10:6F:3F:B3:56:DC | FF:FF:FF:FF:FF:FF | [8899] |
| 20:00.580652 | 60 | A | 00:24:A5:4B:8A:86 | FF:FF:FF:FF:FF:FF | [8899] |

■ Stop measurement

Press [STOP] to finish the measurement. Or it also stops measurement when the trigger condition has been met.

3.5 Display

Press [ENTER] key. Frame display, can be changed to, Detailed display .

■ Frame display

It displays the LAN frames with the time stamp information on the screen.

Time stamp

Source address

Destination address

Protocol

"Time Resolution"

ss.nsec or mm:ss.mssec * 1

↓

hh:mm:ss.mssec

↓

MM/DD hh:mm:ss

↓

YY/MM/DD hh:mm:ss

↓

Δ time(sec) *2

*1: Displayed resolution of time stamp is set in the configuration.

*2: Elapsed time from previous frame.

| Time stamp | Len | P | Source | Dest | Protocol |
|--------------|-----|---|-------------------|-------------------|----------|
| 32:17.445902 | 215 | A | 192.168.0.7 | 239.255.255.250 | UDP |
| 32:18.071925 | 60 | A | 192.168.0.20 | 192.168.0.106 | TCP |
| 32:18.073329 | 60 | B | 192.168.0.106 | 192.168.0.20 | TCP |
| 32:18.123813 | 60 | A | 192.168.0.20 | 192.168.0.106 | TCP |
| 32:18.815690 | 60 | A | 192.168.0.20 | 192.168.0.106 | TCP |
| 32:18.816303 | 60 | B | 192.168.0.106 | 192.168.0.20 | TCP |
| 32:18.837183 | 60 | B | 192.168.0.106 | 192.168.0.20 | TCP |
| 32:18.837412 | 60 | A | 192.168.0.20 | 192.168.0.106 | TCP |
| 32:19.222895 | 60 | A | 00:24:A5:4B:8A:86 | FF:FF:FF:FF:FF:FF | [8899] |
| 32:19.420985 | 60 | A | 10:6F:3F:B3:56:DC | FF:FF:FF:FF:FF:FF | [8899] |
| 32:20.767703 | 60 | A | 192.168.0.20 | 192.168.0.106 | TCP |
| 32:20.769108 | 60 | B | 192.168.0.106 | 192.168.0.20 | TCP |
| 32:20.811334 | 60 | A | 192.168.0.20 | 192.168.0.106 | TCP |
| 32:21.222682 | 60 | A | 00:24:A5:4B:8A:86 | FF:FF:FF:FF:FF:FF | [8899] |
| 32:21.343442 | 60 | A | 192.168.0.20 | 192.168.0.106 | TCP |

Press [SHIFT]+ “Relative Time” to start the time stamp from zero when it starts measuring.

You can scroll the screen by [▲] [▼] or swipe.

● PoE

When simultaneous PoE measurement is enabled, the screen switches to the PoE data display. While the measurement is stopped, the display position automatically shifts to the PoE data closest to the time stamp.

| Time stamp | Len | P | Source | Dest | Protocol |
|--------------|-----|---|-------------------|-------------------|----------|
| 32:17.445902 | 215 | A | 192.168.0.7 | 239.255.255.250 | UDP |
| 32:18.071925 | 60 | A | 192.168.0.20 | 192.168.0.106 | TCP |
| 32:18.073329 | 60 | B | 192.168.0.106 | 192.168.0.20 | TCP |
| 32:18.123813 | 60 | A | 192.168.0.20 | 192.168.0.106 | TCP |
| 32:18.815690 | 60 | A | 192.168.0.20 | 192.168.0.106 | TCP |
| 32:18.816303 | 60 | B | 192.168.0.106 | 192.168.0.20 | TCP |
| 32:18.837183 | 60 | B | 192.168.0.106 | 192.168.0.20 | TCP |
| 32:18.837412 | 60 | A | 192.168.0.20 | 192.168.0.106 | TCP |
| 32:19.222895 | 60 | A | 00:24:A5:4B:8A:86 | FF:FF:FF:FF:FF:FF | [8899] |
| 32:19.420985 | 60 | A | 10:6F:3F:B3:56:DC | FF:FF:FF:FF:FF:FF | [8899] |
| 32:20.767703 | 60 | A | 192.168.0.20 | 192.168.0.106 | TCP |
| 32:20.769108 | 60 | B | 192.168.0.106 | 192.168.0.20 | TCP |
| 32:20.811334 | 60 | A | 192.168.0.20 | 192.168.0.106 | TCP |
| 32:21.222682 | 60 | A | 00:24:A5:4B:8A:86 | FF:FF:FF:FF:FF:FF | [8899] |
| 32:21.343442 | 60 | A | 192.168.0.20 | 192.168.0.106 | TCP |

4.4 Display

■ Detailed display

Display the details of the frame, which is displayed on the top of the Frame Display.

“Dump” : The translation view can be changed to the HEX dump view.

● Translation view

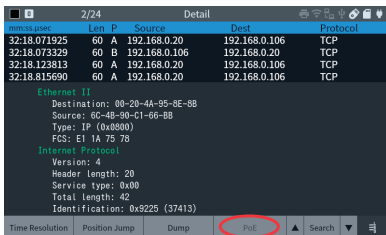

Refer to the specifications of each protocol to understand the contents of the protocol.

If you are using timestamp synchronization, you can check the synchronization status in the GPS/PPS Sync.Status item added to the detail view. Immediately after the start of measurement, as the synchronization is not completed it will be NG, and after synchronization is completed it will be OK.

● HEX dump view



← The target frame for dump view.

It is able to scroll data by swiping the screen.

← Dump display of Ethernet frame.

← Scroll frames by [▲] [▼] keys.

If you are using timestamp synchronization, you can check the synchronization status in the GPS/PPS Sync.Status item added to the detail view. Immediately after the start of measurement, as the synchronization is not completed it will be NG, and after synchronization is completed it will be OK.

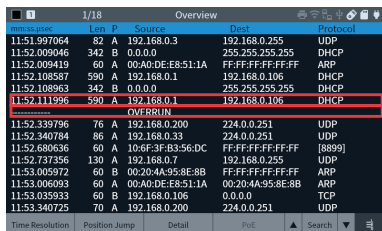

← Broken off Data packet can not be displayed correctly.

← “OVERRUN” display

■ Split Display

The data stored in BUF1 and BUF2 can be displayed simultaneously on the measurement data screen.

By comparing the two measurement data, analysis can be performed more efficiently, such as detecting differences in the event of a failure.

- 1) Save the measurement data in BUF1 or BUF2. On the recording control setting screen, set the buffer to be used to either BUF1 or BUF2, and prepare the measurement data by executing the measurement or loading the file.
- 2) Press [SHIFT] + “Change Buffer” to prepare another measurement data in the other buffer by executing the measurement or loading a file.
- 3) You can display both buffers on one screen by pressing [SHIFT] + “Split Display”.

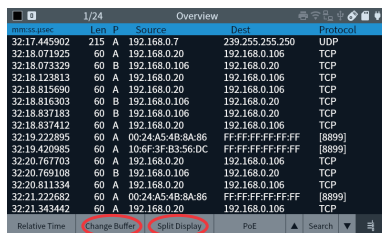

| Time | Len | P | Source | Dest | Protocol |
|--------------|-----|---|-------------------|-------------------|----------|
| 32:17.445902 | 215 | A | 192.168.0.7 | 239.255.255.250 | UDP |
| 32:18.071925 | 60 | A | 192.168.0.20 | 192.168.0.106 | TCP |
| 32:18.073329 | 60 | B | 192.168.0.106 | 192.168.0.20 | TCP |
| 32:18.123813 | 60 | A | 192.168.0.20 | 192.168.0.106 | TCP |
| 32:18.815690 | 60 | A | 192.168.0.20 | 192.168.0.106 | TCP |
| 32:18.816303 | 60 | B | 192.168.0.106 | 192.168.0.20 | TCP |
| 32:18.837183 | 60 | B | 192.168.0.106 | 192.168.0.20 | TCP |
| 32:18.837412 | 60 | A | 192.168.0.20 | 192.168.0.106 | TCP |
| 32:19.222895 | 60 | A | 00:24:AA:4B:8A:86 | FF:FF:FF:FF:FF:FF | [8899] |
| 32:19.420985 | 60 | A | 10:0F:3F:B3:56:DC | FF:FF:FF:FF:FF:FF | [8899] |
| 32:20.767703 | 60 | A | 192.168.0.20 | 192.168.0.106 | TCP |
| 32:20.769108 | 60 | B | 192.168.0.106 | 192.168.0.20 | TCP |
| 32:20.811334 | 60 | A | 192.168.0.20 | 192.168.0.106 | TCP |
| 32:21.222682 | 60 | A | 00:24:AA:4B:8A:86 | FF:FF:FF:FF:FF:FF | [8899] |
| 32:21.943442 | 60 | A | 192.168.0.20 | 192.168.0.106 | TCP |

The two data screens scroll individually, but if you want to scroll at the same time, tap “SYNC”.

You can scroll two data at the same time by pressing the [▲] [▼] keys.

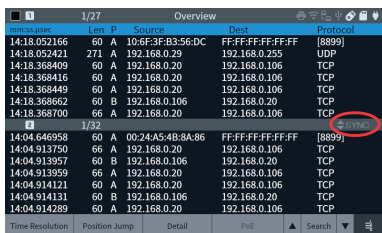

| Time | Len | P | Source | Dest | Protocol |
|--------------|-----|---|-------------------|-------------------|----------|
| 14:18.052166 | 60 | A | 10:0F:3F:B3:56:DC | FF:FF:FF:FF:FF:FF | [8899] |
| 14:18.052421 | 271 | A | 192.168.0.29 | 192.168.0.255 | UDP |
| 14:18.368469 | 60 | A | 192.168.0.20 | 192.168.0.106 | TCP |
| 14:18.368416 | 60 | A | 192.168.0.20 | 192.168.0.106 | TCP |
| 14:18.368449 | 60 | B | 192.168.0.20 | 192.168.0.106 | TCP |
| 14:18.368662 | 60 | B | 192.168.0.106 | 192.168.0.20 | TCP |
| 14:18.368700 | 66 | A | 192.168.0.20 | 192.168.0.106 | TCP |

| Time | Len | P | Source | Dest | Protocol |
|--------------|-----|---|-------------------|-------------------|----------|
| 14:04.646958 | 60 | A | 00:24:AA:4B:8A:86 | FF:FF:FF:FF:FF:FF | [8899] |
| 14:04.913750 | 66 | A | 192.168.0.20 | 192.168.0.106 | TCP |
| 14:04.913957 | 60 | B | 192.168.0.106 | 192.168.0.20 | TCP |
| 14:04.913959 | 66 | A | 192.168.0.20 | 192.168.0.106 | TCP |
| 14:04.914121 | 60 | A | 192.168.0.20 | 192.168.0.106 | TCP |
| 14:04.914131 | 60 | B | 192.168.0.106 | 192.168.0.20 | TCP |
| 14:04.914289 | 60 | A | 192.168.0.20 | 192.168.0.106 | TCP |

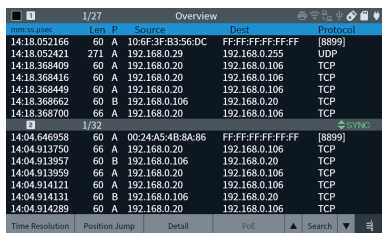

| Time | Len | P | Source | Dest | Protocol |
|--------------|-----|---|-------------------|-------------------|----------|
| 14:18.052166 | 60 | A | 10:0F:3F:B3:56:DC | FF:FF:FF:FF:FF:FF | [8899] |
| 14:18.052421 | 271 | A | 192.168.0.29 | 192.168.0.255 | UDP |
| 14:18.368469 | 60 | A | 192.168.0.20 | 192.168.0.106 | TCP |
| 14:18.368416 | 60 | A | 192.168.0.20 | 192.168.0.106 | TCP |
| 14:18.368449 | 60 | B | 192.168.0.20 | 192.168.0.106 | TCP |
| 14:18.368662 | 60 | B | 192.168.0.106 | 192.168.0.20 | TCP |
| 14:18.368700 | 66 | A | 192.168.0.20 | 192.168.0.106 | TCP |

| Time | Len | P | Source | Dest | Protocol |
|--------------|-----|---|-------------------|-------------------|----------|
| 14:04.646958 | 60 | A | 00:24:AA:4B:8A:86 | FF:FF:FF:FF:FF:FF | [8899] |
| 14:04.913750 | 66 | A | 192.168.0.20 | 192.168.0.106 | TCP |
| 14:04.913957 | 60 | B | 192.168.0.106 | 192.168.0.20 | TCP |
| 14:04.913959 | 66 | A | 192.168.0.20 | 192.168.0.106 | TCP |
| 14:04.914121 | 60 | A | 192.168.0.20 | 192.168.0.106 | TCP |
| 14:04.914131 | 60 | B | 192.168.0.106 | 192.168.0.20 | TCP |
| 14:04.914289 | 60 | A | 192.168.0.20 | 192.168.0.106 | TCP |

■ Position Jump

Display from the specified frame.

Tap “Position Jump” and enter the frame number to jump to.

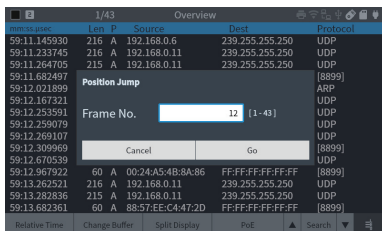

■ Mark & Jump

By marking a frame you can jump to the frame with a single key.

Marks can be added up to 9 places.

When you just made a jump to mark, by the single key you can return to the frame where it was before the mark jump.

Mark set : [SHIFT] + [1]-[9]

Jump to Mark : [1]-[9]

Canceling the jump to Mark : [0]

The marked frame shows the same M1 to M9 as the given key.

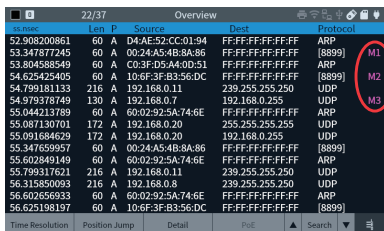

If you execute a numbering operation to a mark where there is the same number, the mark will be deleted.

If you set a mark of a different number, it will overwrite the existing mark.

3.6 Retrieval Function

With the search function, you can find specific data.

The search conditions can be set by tapping “ Search” .

Tap “ Find Next.” “ Find Prev.” From the condition setting screen to execute the search in that direction.

Press “ ▼” “ ▲” on the frame display screen to continue the search.

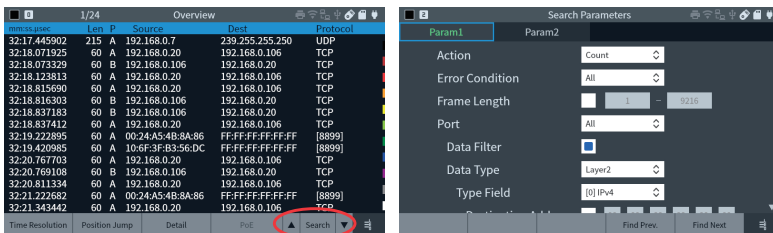

■ Action

Specify on the Param 1 tab.

Select “Display” to jump to the frame that meets the conditions.

Select “Count” to display the number of frames that satisfy the conditions before or after the current cursor position.

■ Param 2 Valid

Condition 2 Specify on the Param 2 tab.

By checking it, you can set condition 2 which is to be searched by condition 1 and OR condition.

■ Error Condition

Select this when you want to search for the frame where the error occurred.

■ Frame Length

When you want to specify the frame length condition, check it and enter the range. Minimum 1 to maximum 9216. Specify a length that does not include FCS.

■ Port

Select to specify a frame of a specific LAN port.

■ Data Filter

When you want to search by the condition of the frame contents, check it and enable the items after this

■ Data Type

Select the type to search from “Layer2” or “IPv4”.

<Layer2>

Set the conditions of MAC header for target frame.

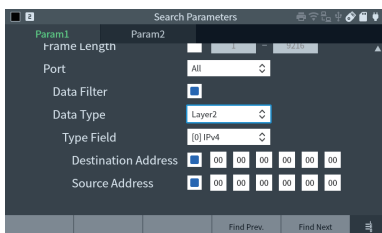

■ Type Field

Select the type field from IPv4, ARP, NetBIOS, IPv6, EtherCAT, Custom (specify the number) and All.

■ Number

Input the type number, in the case of the selecting “Custom” at “Type field”.

■ Destination Address

By checking it, you can specify the destination (Dst) address.

■ Source Address

By checking it, you can specify the source (Src) address.

<IPv4>

Set the conditions of IP header for IPv4 frame.

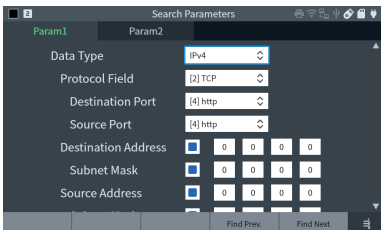

■ Protocol Field

Select the protocol field from ICMP, IGMP, TCP, UDP, Custom (specify the number) and All.

■ Number

Input the protocol number, in the case of the selecting “ Custom ” at “ Protocol Field ” .

■ Destination Port

Input the destination port number when TCP or UDP is selected in the Protocol field.

■ Source Port

Input the source port number when TCP or UDP is selected in the Protocol field.

■ Destination Address

By checking it, you can specify the destination (Dst) address.

■ Source Address

By checking it, you can specify the source (Src) address.

■ Subnet Mask

By checking it you can specify the subnet mask.

The target range is the network address obtained by the bitwise AND calculated by this value and the specified values of destination (Dst) and source (Src) address.

3.7 Trigger Function

Triggers can be made by matching the specified conditions of the frame or by an external input signal.

A trigger can automatically stop the measurement. It is also possible to count the number of frames that match the conditions.

📄 1-2 extra data may be recorded before the actual stop.

Tap “Trigger” from the top menu screen and set the trigger conditions on the trigger setting screen.

■ EXT TRG Enable

When checked, the L level (TTL level) of the external signal connected to IN1 of the external input/output terminal will be the trigger.

◆ Operation

Select either “ Stop RUN” to stop measurement when a trigger occurs, or “Trigger Save” to save the data before and after the trigger to storage.

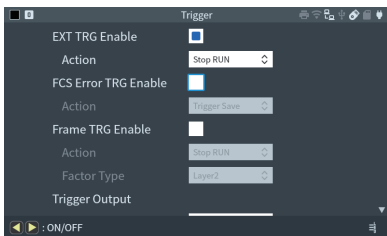

■ FCS Error Trigger

Enable/Disable FCS Error Detection Trigger

◆ Operation

Select either “ Stop RUN” to stop measurement when a trigger occurs, or “Trigger Save” to save the data before and after the trigger to storage.

<Trigger Save Settings>

This option will appear when you select “Trigger Save” in the operation of “External Signal Trigger” or “FCS Error Trigger”.

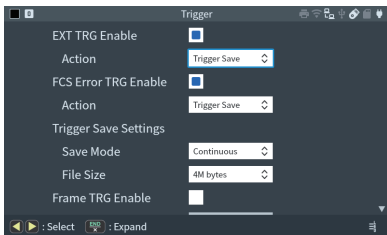

◆ Save Mode

Select the action to take when the remaining capacity of the storage media is insufficient or the maximum number of files is reached.

Max RUN : Stops trigger saving operation. (Measurement does not stop)

Continuous : Deletes the oldest trigger save file and continues recording.

◆ File Size

Select from 2, 4, 8, 16, 32, 46, 128, and 256 MB.

<Trigger Save Function>

This function saves data before and after an external signal trigger occurs during measurement.

The data size before and after the trigger is approximately half the specified file size and is saved with the filename TGSAVnnn.DT (nnn is 000 to 999). The file save media is the same as the setting for the auto-save function.

Trigger save files are saved to the device selected in Record Control → Auto Save tab → Record Device.

- ☰ The trigger save function and the auto-save function cannot be used simultaneously. If you use the trigger save function, please set the auto-save function to “None”.

When trigger saving is performed, the trigger time log file (TGMTSTMP.txt) records the file name and trigger occurrence time as follows. Even with a large amount of data, the trigger location can be easily found.

TGSAV000.DT HH:MM:SS.ooooo0000

- ☰ The number of digits in the ooooo0000 portion changes depending on the timestamp resolution setting.

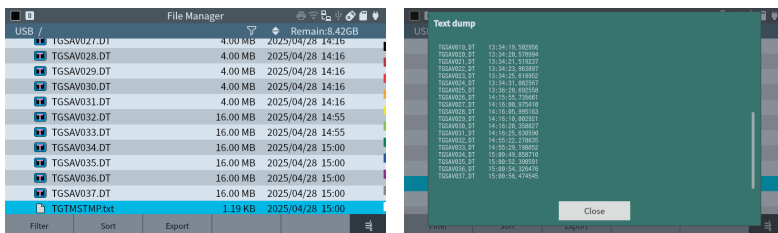

- ☰ The trigger save function is available in system version V1.13 and later. FCS error triggers are available in system version V1.16 and later.

■ Frame TRG Enable

Enable/disable the frame detection trigger.

◆ Action

Select “Stop RUN” to stop the measurement when a trigger occurs or “Count” to count the number of triggers.

◆ Factor Type

Select the frame type from “Layer2” or “IPv4”.

<Layer2>

Configuration of the MAC header of specified frames.

■ Type Field

Select the type field from IPv4, ARP, Net Bios, IPv6, Custom(specified number), or ALL(without specifying).

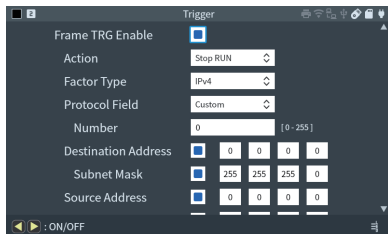

■ Number

Enter a type number when you have chosen “ Custom ” at Type field.

■ Destination Port

Specify the destination port number when TCP / UDP is selected in the protocol field.

■ Source Port

Specify the source port number when TCP / UDP is selected in the protocol field.

The destination (Dst) and source (Src) ports do not work well if the frame’s IP header has options.

<IPv4>

Configuration of the IP header of IPv4 frames

■ Protocol Field

Select the protocol field from ICMP, IGMP, TCP, UDP, Custom(specified number), or ALL(without specifying).

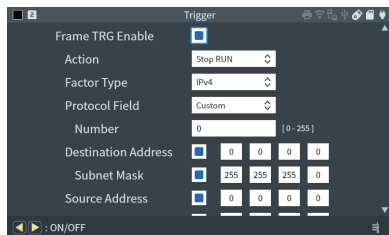

■ Number

Enter a protocol number when you have chosen “Custom” at Protocol field.

■ Destination Port

Specify the destination port number when TCP / UDP is selected in the protocol field.

■ Source Port

Specify the source port number when TCP / UDP is selected in the protocol field.

The destination (Dst) and source (Src) ports do not work well if the frame’s IP header has options.

■ Destination Address

By checking it, you can specify the destination (Dst) address.

■ Source Address

By checking it, you can specify the source (Src) address.

■ Subnet Mask

By checking it you can specify the subnet mask.

The target range is the network address obtained by the bitwise AND calculated by this value and the specified values of destination (Dst) and source (Src) address.

Trigger Output

Set the L level (TTL level) signal width to be output to OUT1 of the external input/output terminal when a trigger occurs.

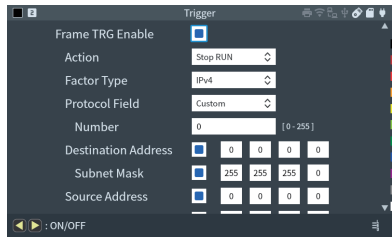

RUN Stop Buzzer

When checked, a buzzer will sound for 2 seconds when the RUN stops due to trigger conditions.

Frame display screen when a trigger occurs

“T” is displayed for the frame where the trigger occurred. If the trigger action is set to “count”, the number of how many triggers occurred will be displayed on the screen.

| Time | Len | Source | Dest | Protocol |
|--------------|-----|---------------------|-------------------|----------|
| 10:06.412167 | 86 | A 349F:7B:46:41:09 | 33:33:00:00:01:51 | IPv6 |
| 10:06.413309 | 86 | A 349F:7B:46:41:09 | 33:33:00:01:00:03 | IPv6 |
| 10:06.414337 | 86 | A 349F:7B:46:41:09 | 33:33:00:00:00:0C | IPv6 |
| 10:06.432499 | 130 | A 28:39:26:9C:1A:6D | 33:33:00:00:00:16 | IPv6 |
| 10:06.702115 | 150 | A SCA:ID:IE:2F:77 | 33:33:00:00:00:16 | IPv6 |
| 10:06.827231 | 150 | A D8:CD:A6:9A:85:15 | 33:33:00:00:00:16 | IPv6 |
| 10:08.865083 | 60 | A BC:5C:4C:A8:8B:C5 | FF:FF:FF:FF:FF:FF | ARP |
| 10:09.865085 | 60 | A BC:5C:4C:A8:8B:C5 | FF:FF:FF:FF:FF:FF | ARP |
| 10:36.375024 | 60 | A 192.168.2.1 | 224.0.0.1 | IGMP |
| 10:36.390122 | 60 | A 192.168.2.100 | 224.0.0.251 | IGMP |
| 10:36.429730 | 60 | A 192.168.2.100 | 224.0.0.252 | IGMP |
| 10:36.430637 | 60 | A 192.168.2.100 | 239.255.255.250 | IGMP |
| 10:36.436274 | 70 | A 192.168.2.103 | 224.0.0.22 | IGMP |
| 10:36.695020 | 70 | A 192.168.2.104 | 224.0.0.22 | IGMP |
| 10:36.814429 | 70 | A 192.168.2.102 | 224.0.0.22 | IGMP |

Additionally, frames received by the external input/output terminal at a low level while trigger save is in use will be marked with “IN”.

| Time | Len | P | Source | Dest | Protocol |
|--------------|-----|---|-------------------|-------------------|-----------|
| 00:54.326468 | 60 | C | F9:F8:F7:F6:F5:F4 | FF:FE:FD:FC:FB:FA | [FFFF] |
| 00:54.326468 | 60 | B | F9:F8:F7:F6:F5:F4 | FF:FE:FD:FC:FB:FA | [FFFF] |
| 00:54.326473 | 60 | A | 06:07:08:09:0A:0B | 00:01:02:03:04:05 | [FFFF] |
| 00:54.326473 | 60 | D | 06:07:08:09:0A:0B | 00:01:02:03:04:05 | [FFFF] |
| 00:54.326474 | 60 | C | F9:F8:F7:F6:F5:F4 | FF:FE:FD:FC:FB:FA | [FFFF] |
| 00:54.326474 | 60 | B | F9:F8:F7:F6:F5:F4 | FF:FE:FD:FC:FB:FA | [FFFF] |
| 00:54.326480 | 60 | A | 06:07:08:09:0A:0B | 00:01:02:03:04:05 | [FFFF] IN |
| 00:54.326480 | 60 | D | 06:07:08:09:0A:0B | 00:01:02:03:04:05 | [FFFF] IN |
| 00:54.326481 | 60 | C | F9:F8:F7:F6:F5:F4 | FF:FE:FD:FC:FB:FA | [FFFF] IN |
| 00:54.326481 | 60 | B | F9:F8:F7:F6:F5:F4 | FF:FE:FD:FC:FB:FA | [FFFF] IN |
| 00:54.326487 | 60 | A | 06:07:08:09:0A:0B | 00:01:02:03:04:05 | [FFFF] |
| 00:54.326487 | 60 | D | 06:07:08:09:0A:0B | 00:01:02:03:04:05 | [FFFF] |
| 00:54.326488 | 60 | C | F9:F8:F7:F6:F5:F4 | FF:FE:FD:FC:FB:FA | [FFFF] |
| 00:54.326488 | 60 | B | F9:F8:F7:F6:F5:F4 | FF:FE:FD:FC:FB:FA | [FFFF] |
| 00:54.326493 | 60 | A | 06:07:08:09:0A:0B | 00:01:02:03:04:05 | [FFFF] |

Chapter 4 PoE(Power over Ethernet) Measurement Function

This function measures power (watt), voltage and current provided from a PSE device (Power Sourcing Equipment) which supports PoE/PoE+ (IEEE802.3af/at) to a PD (Powered Device). It can also distinguish types of power supply and appropriate power range. Select “PoE” from mode the top menu screen to use this function.

4.1 Connection

Connect the device to be measured to PORT A-B or PORT C-D of this unit. Connect the PSE (power supply equipment) to PORT A and C, and the PD (power receiving device) to PORT B and D.

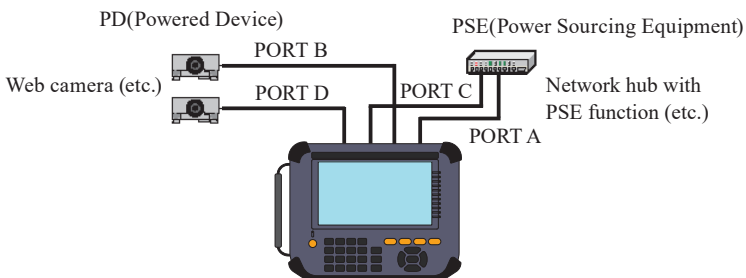

- Cannot measure the PoE line where more than 720mA of current flows for about 3 seconds continuously.

4.2 PoE Setup

Press “ PoE Opt. ” from the PoE mode.

■ Specification

Select the PoE specifications (criteria for judging OK/NG on the judgment screen).

The judgment conditions for the selected specification are displayed on the screen.

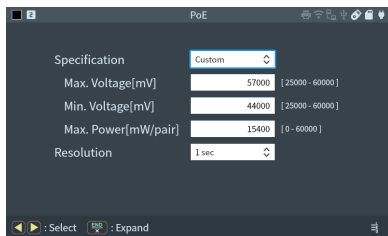

- PoE(PSE) : PoE (PoE+ Type1, PoE++ Type1) judgment on the power supply device side
- PoE+(PSE) : PoE+ Type2, (PoE++ Type2, Type3) judgment on the power supply device side
- PoE++(PSE) : PoE++ Type4 judgment on the power supply device side
- PoE(PD) : PoE (PoE+ Type1, PoE++ Type1) judgment on the power receiving device side
- PoE+(PD) : PoE+ Type2, (PoE++ Type2, Type3) judgment on the power receiving device side
- PoE++(PD) : PoE++ Type4 judgment on the receiving device side
- Custom : Maximum voltage, minimum voltage, maximum power per pair are manually input)

■ Resolution

Select the measurement cycle (interval).

4.3 Start and Stop Measurement

Press [RUN] and start measuring. Press [STOP] to finish measurement.

4.4 Display

By the buttons displayed at the bottom of the screen, it switches in sequence from “Overview”→ “Dump”→ “Graph”.

■ PoE Overview display

It displays the result of PoE measurement.

Power : Power(W)

Voltage : Voltage(V)

Current : Current(mA)

Min voltage : Minimum voltage (V)

Max voltage : Maximum voltage (V)

Min current : Minimum current (mA)

Max current : Maximum current (mA)

+ pin : The numbers of plus(+) pins.

OK/NG : Judgment result. When it is within the range specified in the PoE settings, OK is displayed.

PoE : 44 to 57V, 15.4W or less

PoE+ : 50 to 57V, 30W or less

PoE++ : 52 to 57V, 49.5W or less

📄 The judgment result is displayed when the voltage measurement value exceeds 29V.



■ PoE dump Display window

It displays the list of recorded data.

Time Stamp : Measured time

Power : Power(W)

Voltage : Voltage(V)

Current : Current(mA)

If the values in the list are within the range you set, OK will be displayed under each port.

You can scroll the screen with [▲] [▼] or by swipe.

| Time Stamp | Position | Jump | PoE Type | A/V | Online | Graph | Power | Voltage | Current |
|----------------|----------|------|----------|-----|--------|-------|-------|---------|---------|
| 00,000,024,766 | OK | 1,6 | 53,9 | 30 | 0,0 | 1,1 | 8 | | |
| 00,000,024,768 | OK | 0,6 | 53,9 | 11 | 0,0 | 1,1 | 8 | | |
| 00,000,024,770 | OK | 0,6 | 53,7 | 11 | 0,0 | 1,1 | 8 | | |
| 00,000,024,772 | OK | 2,5 | 53,8 | 47 | 0,0 | 1,1 | 8 | | |
| 00,000,024,774 | OK | 0,9 | 53,9 | 17 | 0,0 | 1,1 | 8 | | |
| 00,000,024,776 | OK | 0,3 | 53,9 | 6 | 0,0 | 1,1 | 8 | | |
| 00,000,024,778 | OK | 3,0 | 53,7 | 55 | 0,0 | 1,1 | 8 | | |
| 00,000,024,780 | OK | 1,6 | 53,9 | 29 | 0,0 | 1,1 | 8 | | |
| 00,000,024,782 | OK | 0,5 | 53,9 | 10 | 0,0 | 1,1 | 8 | | |
| 00,000,024,784 | OK | 2,7 | 53,5 | 51 | 0,0 | 1,1 | 8 | | |
| 00,000,024,786 | OK | 2,4 | 53,8 | 44 | 0,0 | 1,1 | 8 | | |
| 00,000,024,788 | OK | 1,0 | 53,9 | 18 | 0,0 | 1,1 | 8 | | |
| 00,000,024,790 | OK | 1,1 | 53,6 | 20 | 0,0 | 1,1 | 8 | | |
| 00,000,024,792 | OK | 2,9 | 53,7 | 54 | 0,0 | 1,1 | 8 | | |
| 00,000,024,794 | OK | 0,6 | 53,9 | 11 | 0,0 | 1,1 | 8 | | |

You can move the position by tapping “Position Jump” and entering the position jump number. Tap “Timestamp” to switch the timestamp display between relative time with the measurement start time as 0 and real-time displayed as hh:mm:ss.msec.

Each time you tap “PoE Type A/B” on the PoE judgment screen or the PoE dump display screen, the display switches to show TypeA, TypeB, or the combined current and power values of TypeA and TypeB.

■ PoE graph display

You can switch between show/hide of the graph of the specified data with the check box on the right side of the screen.

Below each check box, the

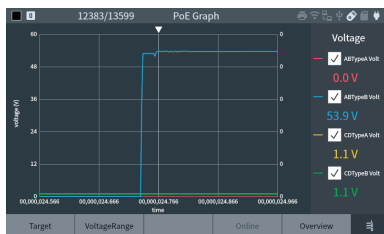

latest data is displayed during measurement, and the numerical value of the data at the cursor position is displayed while measurement is stopped.

Each time you tap “Target”, the graph display target is switched.

Depending on the graph display target, the range of the vertical axis of the graph changes each time you tap “ VoltageRange” “ CurrentRange” or “PowerRange” .

Press [SHIFT]+[◀] [▶] to scroll at high speed.

■ Simultaneous online monitor measurement

During simultaneous measurement with the online monitor, tap “Online” on each screen to return to the LAN frame display screen.

While the measurement is stopped, the display position automatically shifts to the frame closest to the time stamp.

Chapter 5 Delay time measurement function

Delay Time Measurement Function is a function to measure a time gap between the receiving timings of the ports judging from the send/receive time of LAN communication frames on the network. This function is useful for evaluation of real time Ethernet devices. Select “Delay” from mode on the top menu screen.

5.1 Port Selection to Measure

Tap “Delay Opt.” from the Delay time measurement mode and select the ports to measure the time gap. It measures the time gap between the ports specified by “Begin Factor” and “End Factor”.



< Setting example1 >

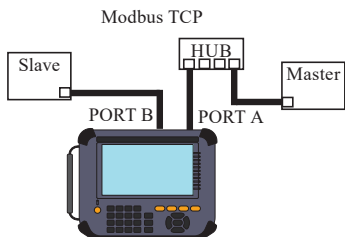

Connect it with a Modbus TCP, configure the layer 2 filter, and set “A-B Tx” to Begin Factor and “A-B Rx” to End Factor. By this setting you can measure the response time of the Slave against the command from the Master.

< Setting example2 >

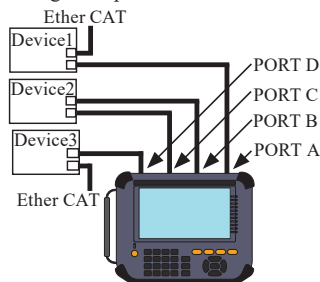

Connect it with an Ether CAT, configure the layer 2 filter, and set “A-B Tx” to Begin Factor and “C-D Tx” to End Factor. By this setting you can measure the processing (response) time of the Device 2 of Ether CAT.

5.2 Start and Stop Measurement

Start measurement

Press [RUN] to start the measurement and display the time gap in real time.

■ **Count**

Means how much times measured.

■ **Last**

Means the latest time gap.

■ **Minimum**

Means the minimum time gap.

■ **Maximum**

Means the maximum time gap.

■ **Average**

Means the average of the time gaps during the measurement.

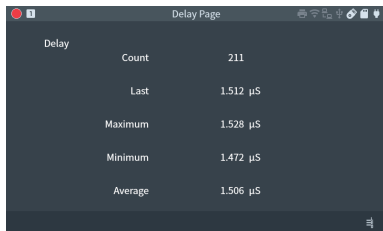

The screenshot shows a dark-themed window titled 'Delay Page'. It contains a table with the following data:

| Delay | Count | 211 |
|-------|---------|---------------|
| | Last | 1.512 μ S |
| | Maximum | 1.528 μ S |
| | Minimum | 1.472 μ S |
| | Average | 1.506 μ S |

Stop measurement

Press [STOP] to finish the measurement.

Chapter 6 Manual Simulation Function

The statistic function is a useful feature to analyze the network traffic and the frequency of the particular frames. To use this function, select “Trend” from mode on the top menu screen.

6.1 Connection

Connect the target network to the port A/B/C/D of analyzer.

 3.1 Outline

6.2 Settings

Start the measurement. Following frames are counted separately by transmission and reception.

Select two kinds of frames for statistical analysis.

| | |
|--------------------|---|
| Total | : Total number of receiving frames |
| Good | : Number of normal frames |
| Broadcast | : Number of broadcasts |
| Multicast | : Number of multicasts |
| Pause | : Number of pause frames |
| 0-63(Length1) | : Number of 0 to 63 byte packets |
| 64(Length2) | : Number of 64 byte packets |
| 65-127(Length3) | : Number of 65 to 127 byte packets |
| 128-255(Length4) | : Number of 128 to 255 byte packets |
| 256-511(Length5) | : Number of 256 to 511 byte packets |
| 512-1023(Length6) | : Number of 512 to 1023 byte packets |
| 1024-1518(Length7) | : Number of 1024 to 1518 byte packets |
| 1519-Over(Length8) | : Number of 1519 byte packets and above |
| CRC error | : Number of CRC errors |
| Fragment error | : Number of fragment errors ^{*1} |
| Data Rate(1sec.) | : Current data transfer rate (updated every second) ^{*2} |
| Data Rate(Avg) | : Average data transfer rate at the time interval specified on the setting screen |
| PoE Power | : Current PoE power |
| PoE Power (Avg) | : Power usage during the time interval specified on the settings screen. |

*1 Frame where an FCS error occurs and its packet length is less than 64 bytes.

*2 This value cannot be set as a statistical analysis target for graph display.

6.3 Statistical analysis settings

Tap “Trend Opt.” from the Statistical analysis function mode.

■ Target

Select the target from transmission line and reception line.

Tx : Transmission signal

Rx : Reception signal

■ Type

Select the target frame counter.

■ Resolution unit

Select the unit of the counting cycle from seconds or minutes.

■ Resolution

When the counting cycle unit is minutes, enter the counting cycle (resolution of the horizontal axis of the statistical graph) in the range of 1 to 240 (minutes), and when it is seconds, enter in the range of 2 to 240 (seconds).

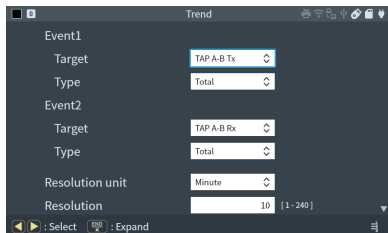

6.4 End

Press [STOP] to stop the measurement operation.

■ Start measurement

Press [RUN] to start measuring.

■ Stop measurement

Press [STOP] to stop measuring.

A measurement is automatically terminated when 100,000 statistics are completed or one of the statistics counters reaches the maximum count of 4,294,967,295.

6.5 Display

Each time you tap “Graph” or “Counter”, the display changes.

■ Graph display

Counted values are shown in histogram by unit time of statistics.

“Auto Range ON/OFF” :

Enables/disables the auto range function.

“Range UP” [▲]

“Range Down” [▼] :

When auto range is off, the resolution of the vertical axis of the graph is changed.

After the measurement is completed, you can scroll the screen with [▲][▼] or by swipe.

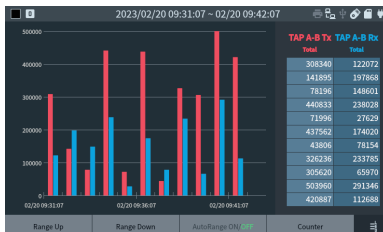

■ Stop measurement

Press [STOP] to stop measuring. A measurement is automatically terminated when 100,000 statistics are completed or one of the statistics counters reaches the maximum count of 4,294,967,295.

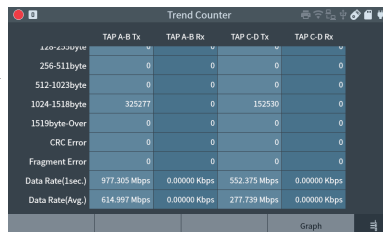

Chapter 7 Packet Difference Measurement Function

The packet difference measurement function compares the contents of Ethernet communication frames flowing through the network between ports. This function is useful for evaluating EtherCAT, which communicates on-the-fly. Select “PacketDiff” from Mode on the top menu screen.

7.1 Connection method

Connect between the EtherCAT Master and Slave as shown in the figure. You can compare packets sent from the EtherCAT Master and packets that pass through the Slave and return.

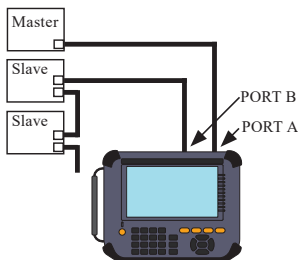

7.2 Packet Difference Measurement Settings

■ Select the Measurement Port

Tap “PacketDiff Opt.” on the packet difference measurement mode screen and set the ports where you want to compare packets. Packets from the ports set in the “Start Port” and “End Port” will be captured.

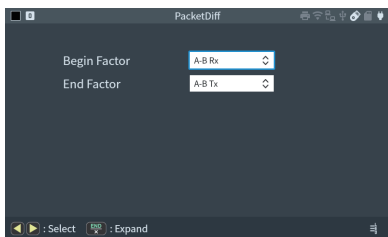

■ Set the Filter

Tap “Filter” on the packet difference measurement mode screen and set the filter to be used for each port.

 3.2 Filter Setup

* All ports that are not the start port or end port will be filtered and the data on the ports will not be captured.

7.3 Start and End Measurements

- Start a measurement
Press [RUN] to start the measurement.
When you want to end the measurement, press [STOP].

7.4 Display screen

- List display screen

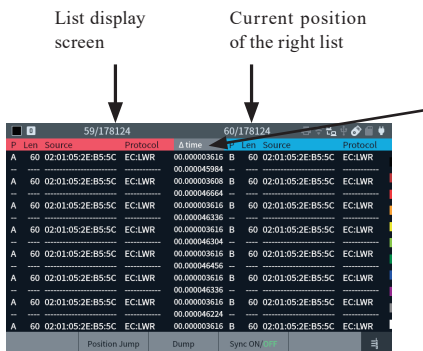

While measurement is in progress, the timestamp of the received packet is displayed. While measurement is stopped, the difference in the timestamp of the packets on the left and right sides of the same line is displayed..

The content received at the start port is displayed on the left, and the content received at the end port on the right. When “Sync ON/OFF” is selected, each list can be scrolled asynchronously.

When “Sync ON ” is selected, the lists will move in sync.

When “Sync OFF” is selected, the key operations are as follows.

- [◀] : Move up the list on the left
- [▼] : Move down the list on the left
- [▲] : Move up the list on the right
- [▶] : Move down the list on the right

- Dump display screen**
 Clicking “Dump” will display a hexadecimal dump of the first frame. Each dump position is compared, and any differences are displayed in color.



- Detailed display screen**
 Clicking “Detail” will display the translation of the first frame. If the data on the left and right are the same length and use the same protocol, the differences will be displayed in color.



- Position Jump**
 Clicking “Go” will display the Position Jump dialog. Enter the frame number to jump to and select whether to apply it to the left or right list.

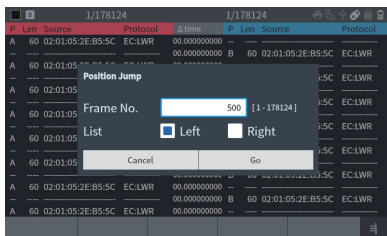

Chapter 8 Save and Load of the Data

Tap “File Manager” on the top menu screen to save and read measurement data on the file management screen.

For operating instructions and details, please refer to the LE-8600X series and LE-8500X series instruction manual “Save and Load of the Data”.

8.1 Export data function

You can save the current display data in pcap format, txt format and csv format. Tap [SHIFT]+“Export” on the file manager screen to display the dataexport dialog.

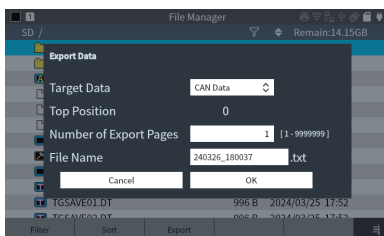

■ Export Type

Select the file output format.

- pcapng : Outputs ONLINE monitor measurement data in a format that can be opened in Wireshark.
- csv : Output PoE and TREND measurement data in csv format.
- txt : Output ONLINE, PoE, TREND measurement data in txt format.

- When the measurement data is “ONLINE monitor” and the output format is txt

■ Data Type

From the current position, it transforms the frame display screen by selecting “List” and transforms the detail display screen by selecting “Detail”.

■ Number of Pages

Select how many pages to convert from the current position when the data type is List. (15 lines per one page.)

■ **Number of Lines**

Select how many rows of frames to convert from the current position when the data type is Detail.

- When the measurement data is PoE

■ **Current Position / Total Data**

Displays the top data position currently displayed on the PoE dump screen and the total number of captured data.

■ **Start Position**

Enter the position to start converting PoE data.

The initial value is the current display position.

■ **Number of Convert Lines**

Enter the number of lines to convert from the starting position.

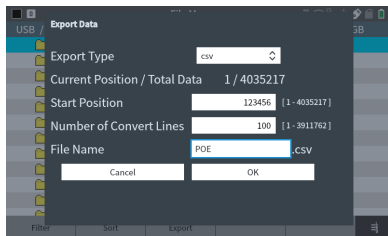

- When the measurement data is ONLINE and PoE simultaneous measurement and the output format is txt

■ **Export Data**

Select the measurement data to output.

The subsequent selection items are the selections for each of the above measurement data.

- When the measurement data is TREND

■ **Data Type**

Select whether the output format is counter or graph.

■ **Top Position**

Displays the top position of the current graph screen.

■ **Resolution**

Displays the resolution of the measurement data.

■ **Number of Data**

Select how many to output from the current top position.

■ File Name

Enter a file name. When selected, a file name input dialog is displayed.

Tap “OK” or press [ENTER] to save the file to your storage device.

◆ List Data

```
*=[LE-8500XR]===[2024-08-01 10:29:31]*
* Model       : LE-8500XR      *
* Version     : 1.00.00       *
* Extension   : SB-FE2        *
* Serial No.  : 99999999      *
* Start time  : 2024-08-01 10:28:13 *
* Stop time   : 2024-08-01 10:29:20 *
*-----*
* PROTOCOL: LAN              *
*-----*
-----Time--Len-P---Source-----Destination---Protocol
35:52.671588 66 B 192.168.0.14 192.168.0.47 TCP
35:52.671991 66 B 192.168.0.47 192.168.0.14 TCP
35:52.672159 60 B 192.168.0.14 192.168.0.47 TCP
35:52.675590 584 A 192.168.0.47 192.168.0.14 TCP
35:52.716697 60 B 192.168.0.14 192.168.0.47 TCP
35:52.749521 80 B 192.168.0.14 192.168.0.47 TCP
35:52.749553 60 A 192.168.0.47 192.168.0.14 TCP
35:53.213522 1478 B 192.168.0.14 192.168.0.47 TCP
35:53.213902 60 A 192.168.0.47 192.168.0.14 TCP
35:53.215931 134 B 192.168.0.14 192.168.0.47 TCP
35:53.215960 60 A 192.168.0.47 192.168.0.14 TCP
35:53.295903 710 A 192.168.0.47 192.168.0.14 TCP
35:53.305719 70 B 192.168.0.14 192.168.0.47 TCP
35:53.305790 60 A 192.168.0.47 192.168.0.14 TCP
36:23.920244 119 B 192.168.0.14 192.168.0.47 TCP
```

◆ Detail Data

```
*=[LE-8500XR]===[2024-08-01 10:29:31]*
* Model       : LE-8500XR      *
* Version     : 1.00.00       *
* Extension   : SB-FE2        *
* Serial No.  : 99999999      *
* Start time  : 2024-08-01 10:28:13 *
* Stop time   : 2024-08-01 10:29:20 *
*-----*
* PROTOCOL: LAN              *
*-----*
-----Time--Len-P---Source-----Destination---Protocol
35:52.671588 66 B 192.168.0.14 192.168.0.47 TCP
Ethernet II
 Destination: 98-FD-15-02-0C-F0
 Source: 03-3F-35-A4-10-54
 Type: IP (0x0800)
 FCS: B6 31 07 76
 Internet Protocol
 Version: 4
 Header length: 20
 Service type: 0x00
 Total length: 62
 Identification: 0xCFD (53053)
 Flags: 0x02
 Fragment offset: 0
 Time to live: 128
 Protocol: TCP (0x06)
 Header checksum: 0xA9F8 - correct
 Source: 192.168.0.14
 Destination: 192.168.0.47
 Transmission Control Protocol
 Source port: 1366
 Destination port: ssh (22)
 Sequence number: 165437364
 Acknowledgment number: 0
 Retransmit: 0
```

Chapter 9 Printout function

Measurement data can be printed out or a hard copy of the screen can be output to a dedicated printer SM4-31W (optional) connected to this device via USB or wireless LAN. For information on how to connect to a printer and how to operate it, please see “Printout Function” in the LE-8600X/LE-8500X series instruction manual.

Display data can be printed out in the same format as when saving a file in text format to external storage. See Chapter 8 for output examples.



8.1 Export data function

Chapter 10 Specifications

| Item | SB-EF2 |
|--|---|
| Applicable analyzers | LE-8600X series, LE-8500X series |
| Measurement interface | RJ-45 connector Ports A, B, C, D: 100BASE-TX/10BASE-T Through connection tap specification between ports A-B and C-D *1 |
| Online monitor function | 2-channel simultaneous recording and real-time display of LAN frames flowing between ports A-B and C-D |
| Suitable frame size | 60 bytes to 9KB |
| Time stamp | The reception time is added as time stamp data for each received frame Resolution: 8n seconds/1u seconds/10u seconds can be selected |
| Detailed translation | Target protocols: IPv4, ARP, ICMP, TCP, UDP, DHCP, EtherCAT, IPv6, ICMPv6 |
| pcap conversion | Measurement data can be converted to a pcapng format file and saved |
| csv conversion | Measurement data can be output as a csv format file |
| txt conversion | Measured data can be output as a txt file |
| Filter function | Can monitor only specific frames that match one or two specified conditions |
| Trigger function | Factor: When a specified frame is received, when an FCS error occurs, when the external TTL signal changes Action: Automatically stops monitoring (buzzer notification possible), counts the number of condition matches, saves preceding and succeeding data to a file (trigger save), outputs an external TTL signal |
| Search function | Can search for, cue, and count only specific frames that match the specified conditions from the measured data |
| Delay time measurement function | Tx between specified ports or Rx, measures the time difference between the two reception timings in μ second units, and displays the current, maximum, minimum, and average values as delay times |
| Statistical analysis function | Two frame counter values are collected at specified intervals (2 to 240 seconds, 1 to 240 minutes) and displayed as graphs, and all frame counter values, data rates and PoE can be displayed in real time |
| PoE Power | Supports PoE/PoE+/PoE++ (IEEE802.3af/at/bt), and can measure simultaneously with LAN frames Recording interval: 1ms to 1s, Maximum number of records: 16.77 million, Voltage measurement range: 0 to 60V (Accuracy: $\pm 1\%$ F.S.), Current measurement range: 0 to ± 900 mA (Accuracy: $\pm 1\%$ F.S.) |
| Packet difference measurement function | Compares received packets between specified ports and displays the differences |
| Other functions | Auto-save function, automatic backup function, time-specified automatic RUN/STOP function, file management function, printout function |
| Components | Interface sub board piece, LAN cable (2), External signal I/O cable, Quick Start Guide, Warranty |

*1 : The tap is the fail-safe tap circuit that maintains the link between the measurement targets even when the power is turned off.

Chapter 11 After Support and Maintenance

11.1 Factory reset

By the Factory reset operation, you can initialize the internal status of this analyzer and return the settings to the factory settings.

■ How to

Tap “Factory reset” on the “Version” tab of “System Settings”. If you tap “OK” in the confirmation message, the main unit will automatically shut down and the settings will be initialized when you boot it next time.

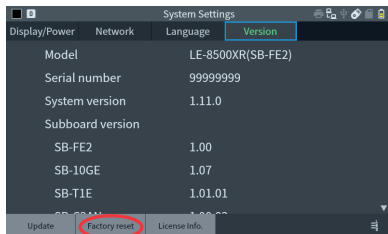

11.2 Warranty and After service

Warranty

■ When you face any problems, please contact LINEEYE distributors or LINEEYE

■ Warranty

Within a period of 12 months from the date of shipment, LINEEYE warrants that your purchased products (except consumable parts such as the battery and software) are free of charge from any defects in material and workmanship, only when the products are operated in accordance with procedures described in the documents supplied by LINEEYE.

If the defects exist during the Warranty period, please send back the products to LINEEYE distributors or LINEEYE. LINEEYE will repair or exchange them at no charge. In this case, the shipping charge will be at your own expense. The foregoing warranties are the sole warranties given by LINEEYE. Above warranties shall not be applied to the products that have been modified, repaired or altered (except by LINEEYE) or that have been subjected to unusual physical or electrical stress, misuses, abuse, negligence or accidents. LINEEYE disclaims all other warranties including the warranties of merchantability fitness for some particular purpose and noninfringement of third party right. LINEEYE cannot promise that the software is error-free or will operate without any interruption.

User Registration

User registration is required to receive appropriate after-sales support. Please register as a user using the user registration form on our website.
<https://www.lineeye.co.jp/html/support.html>

Repair

For malfunction, please contact LINEEYE distributors or LINEEYE and tell us following details.

| | |
|---------------|------------------------|
| Model | SB-FE2 |
| Serial Number | 8 digit numbers |
| Purchase Date | Year, Month, Day |
| Other | Details of malfunction |

- Repair during warranty period
LINEEYE repairs, following the repair instruction.
Please provide the details of malfunction.

- Repair after warranty period
LINEEYE will repair the products at our own expense.

- Calibration
Enable to have a hardware calibration test by the line monitor

After Support

Read “FAQ” in our Website or email us.
Please refer to “FAQ”. We also have support by email regarding the technical issue. When you use it, please register your product via our website.

Website : <https://www.lineeye.com>

There is a registration page on our web site.
(<https://www.lineeye.com>)
Please register your product for further support.
We will provide you the firmware update
information and sales information etc.

LINEEYE CO., LTD.

4F., Marufuku Bldg., 39-1, Karahashi Nishihiragaki-cho, Minami-ku,
Kyoto, 601-8468, Japan

Phone : 81-75-693-0161 Fax : 81-75-693-0163

URL <https://www.lineeye.com> Email :info@lineeye.co.jp

Printed in Japan

M-36FE2E/LE